



*SOLID CARBIDE DRILLS  
& END MILLS*



**ATOM**

**切削工具総合カタログ**  
ATOM CUTTING TOOLS GENERAL CATALOG

2019-2020 **Vol.8.1**

# アイコンの見方

## Guide to Icons

### 工具素材 Tool Material



超硬合金  
Tungsten Carbide



超微粒子合金  
Micro grain Carbide

### 表面処理 Coating



FCS コーティング (TiAlN系)  
FCS Coating (TiAlN)



TiAlN コーティング  
TiAlN Coating

### ドリル先端角 Point Angle(Drill)



90°



130°



118°



135°



120°



140°

### ドリルシャンク径 Shank Diameter



1mmシャンク  
1mm Shank



3mmシャンク  
3mm Shank



3.175mmシャンク  
3.175mm Shank



刃径=シャンク径

### 刃部のねじれ角 Helix Angle



25° ねじれ  
Helix Angle 25°



30° ねじれ  
Helix Angle 30°



30°~40° ねじれ  
Helix Angle 30°~40°

### 刃長 Flute Length



ショート刃長  
Short flute length



標準刃長  
Regular flute length



セミロング刃長  
Semi Long flute length



ロング刃長  
Long flute length

### シンニング形状 Thinning form



Xシンニング形状 (ドリル)  
X-Thinning (Drill)

### エンドミルの刃数 Number of Flutes



2枚刃スクエア  
2-Flute Square End Mill



4枚刃スクエア  
4-Flute Square End Mill



2枚刃ボール  
2-Flute Ball End Mill



4枚刃ボール  
4-Flute Ball End Mill

**ドリル早見表**

## Simplified Drill Table





















**超硬ドリル SOLID CARBIDE DRILLS**

- ルーマ型ドリル (同一シャンクシリーズ)  
Common Shank Drill Series
- ストレートシャンクドリル  
Drills, Straight Shank Series
- NC ポインティングドリル  
NC Pointing Drill
- ローソク型ドリル  
Sweep Cut Drill
- 特定在庫品  
Stocked by Specific Distributors

















**超硬エンドミル SOLID CARBIDE END MILLS**

- スクエアエンドミル  
Square End Mill
- ボールエンドミル  
Ball End Mill
- テーパーエンドミル・テーパーボール  
Taper End Mill・Taper Ball
- ラジアス・コーナー Rカッター・直刃タイプ  
Radius End Mill・Corner R Cutter・Straight Flute













**ドリル切削条件 Drilling Conditions****エンドミル切削条件 Milling Conditions****参考資料 Data**

用途 Application	名称 Product Name	型番 Model	ドリル外観 Appearance	適用径 Diameter	ページ Page
<b>ルーマ型ドリル Micro Drill Common Shank Series</b>					
精密加工用ドリル Precision Micro Drill	ルーマドリル ショート刃 Micro drill, Short Flute	ADRS		φ0.1~ φ3.0	p.42
	ルーマドリル 標準刃長 Micro drill, Standard Flute	ADR		φ0.02~ φ3.0	p.46
	ルーマドリル セミロング刃 Micro drill, Semi Long Flute	ADRSL		φ0.03~ φ3.0	p.50
	ルーマドリル ロング刃 Micro drill, Long Flute	ADRL		φ0.03~ φ3.0	p.52
	ルーマドリル 3.175mmシャンク Micro drill, 1/8" shank	ADR31		φ0.04~ φ1.5	p.56
	h4 シャンク ルーマドリル h4 shank Micro Drill	ADR-h4		φ0.02~ φ0.1	p.59
	ハイスプレックドリル Super precision Micro drill	ADR-SP		φ0.035~ φ1.995	p.60
	マイクロドリル "NEO-PRO" ショート刃 Micro drill "NEO-PRO" Series, Short Flute	FCS Coating ADRS-SV		φ0.1~ φ3.0	p.63
	マイクロドリル "NEO-PRO" 標準刃長 Micro drill "NEO-PRO" Series, Standard Flute	FCS Coating ADR-SV		φ0.03~ φ3.0	p.67
	マイクロドリル "NEO-PRO" セミロング刃 Micro drill "NEO-PRO" Series, Semi Long Flute	FCS Coating ADRSL-SV		φ0.03~ φ3.0	p.71
	マイクロドリル "NEO-PRO" ロング刃 Micro drill "NEO-PRO" Series, Long Flute	FCS Coating ADRL-SV		φ0.03~ φ3.0	p.73
	難削材用 マイクロドリル Micro drill for Hard-to-Cut Materials	FCS Coating ADR-SUS		φ0.1~ φ3.0	p.77
	難削材用 マイクロドリル ロング刃 Micro drill for Hard-to-Cut Materials, Long Flute	FCS Coating ADRL-SUS		φ0.1~ φ3.0	p.81
微小径スパイラルフルート 1mm シャンク Micro twist drill, 1mm shank	AMSD		φ0.05~ φ0.99	p.85	
<b>ストレートシャンクドリル Straight Shank Drill Series</b>					
一般用ストレート シャンクドリル Straight Shank Drill	標準ソリッドドリル Solid Standard Drill	ADS		φ0.3~ φ13	p.88
	セミロングドリル Semi Long Drill	ADSL		φ0.3~ φ13	p.97
	ロングドリル Long Drill	ADL		φ0.3~ φ13	p.100
	スーパーロングドリル Super Long Drill	ADLL		φ0.3~ φ13	p.103
	コーティング付標準ソリッドドリル Coated Standard Drill	TiAlN Coating V-ADS		φ0.3~ φ6	p.106
	アルミ用 for Alumi	マックスアルドリル "MAXAL" Drill, for Aluminium	ACD		φ1.0~ φ12

型番 Model	炭素鋼 Carbon Steel	合金鋼 Alloy Steel	調質鋼 Prehardened Steel	焼入鋼 ~50HRC Hardened Steel	ステンレス鋼 Stainless Steel	アルミ合金 Aluminium Alloy	樹脂・エンブラ Resin Engineering Plastic
<b>ADRS</b>	○	○	○	—	○	◎	◎
<b>ADR</b>	○	○	○	—	○	◎	◎
<b>ADRSL</b>	○	○	○	—	○	◎	◎
<b>ADRL</b>	○	○	○	—	○	◎	◎
<b>ADR31</b>	○	○	○	—	○	◎	◎
<b>ADR-h4</b>	○	○	○	—	○	◎	◎
<b>ADR-SP</b>	○	○	○	—	○	◎	◎
<b>ADRS-SV</b>	◎	◎	◎	○	○	○	○
<b>ADR-SV</b>	◎	◎	◎	○	○	○	○
<b>ADRSL-SV</b>	◎	◎	◎	○	○	○	○
<b>ADRL-SV</b>	◎	◎	◎	○	○	○	○
<b>ADR-SUS</b>	○	○	○	○	◎	—	—
<b>ADRL-SUS</b>	○	○	○	○	◎	—	—
<b>AMSD</b>	○	○	○	—	○	◎	◎
<b>ADS</b>	○	○	○	—	○	◎	◎
<b>ADSL</b>	○	○	○	—	○	◎	◎
<b>ADL</b>	○	○	○	—	○	◎	◎
<b>ADLL</b>	○	○	○	—	○	◎	◎
<b>V-ADS</b>	◎	◎	◎	◎	○	◎	◎
<b>ACD</b>	—	—	—	—	—	◎	◎

用途 Application	名称 Product Name	型番 Model	ドリル外観 Appearance	適用径 Diameter	ページ Page			
<b>NC ポインティングドリル NC Pointing Drill</b>								
ガイド穴専用ドリル Guide Hole Drill	先端角 120° 120° point angle	鋼材用	3mmシャンク for Ferrous	ADPF30		φ0.03~ φ3.0	p.115	
			3mmシャンク for Ferrous	 V-ADPF30		φ0.03~ φ3.0	p.116	
		非鉄・樹脂用	3.175mmシャンク for Ferrous	ADPF31		φ0.03~ φ3.0	p.117	
			3.175mmシャンク for Ferrous	 V-ADPF31		φ0.03~ φ3.0	p.118	
		先端角 90° 90° point angle	鋼材用	3mmシャンク for Ferrous	ADPF309		φ0.03~ φ3.0	p.121
				3mmシャンク for Ferrous	 V-ADPF309		φ0.03~ φ3.0	p.122
	非鉄・樹脂用		3mmシャンク for Non-Ferrous	ADPN309		φ0.03~ φ3.0	p.123	
	<b>ローソク型ドリル Sweep Cut Drill</b>							
	特殊用途 Special Application	スイープカットドリル、3mmシャンク Sweep Cut Drill 3mm Shank	ASWR		φ0.1~ φ3.0	p.124		
スイープカットドリル、ストレートシャンク Sweep Cut Drill Straight Shank		ASWD		φ1.0~ φ6.0	p.125			
<b>特定在庫品 Stocked by Specific Distributors</b>								
精密加工用ドリル Precision Micro Drill	微小径 ソリッドドリル 1~2mmシャンク Miniature Micro Drill 1-2mm shank	ACDR		φ0.1~ φ1.95	p.126			
	コーティングルーマドリル ショート刃 Coated Micro drill, Short Flute	 CX-ADRS		φ0.3~ φ1.0	p.128			
	コーティングルーマドリル ロング刃 Coated Micro drill, Long Flute	 CX-ADRL		φ0.3~ φ1.0	p.129			

型番 Model	炭素鋼 Carbon Steel	合金鋼 Alloy Steel	調質鋼 Prehardened Steel	焼入鋼 ~50HRC Hardened Steel	ステンレス鋼 Stainless Steel	アルミ合金 Aluminium Alloy	樹脂・エンブラ Resin Engineering Plastic	
ADPF30	○	○	○	—	○	—	—	
V-ADPF30	◎	◎	◎		◎	—	—	
ADPF31	○	○	○	—	○	—	—	
V-ADPF31	◎	◎	◎		◎	—	—	
ADPN30	—	—	—	—	—	◎	◎	
ADPN31	—	—	—	—	—	◎	◎	
ADPF309	○	○	○	—	—	—	—	
V-ADPF309	◎	◎	◎		◎	—	—	
ADPN309	—	—	—	—	—	◎	◎	
ASWR	—	—	—	—	—	◎	◎	
ASWD	—	—	—	—	—	◎	◎	
ACDR	○	○	○	—	○	◎	◎	
CX-ADRS	◎	◎	◎	○	○	○	○	
CX-ADRL	◎	◎	◎	○	○	○	○	

用途 Application	名称 Product Name	型番 Model	エンドミル外観 Appearance	適用径 Diameter	ページ Page
<b>スクエアエンドミル Square End Mill</b>					
スクエア Square	2枚刃 微小径エンドミル 2-flute, Miniature End Mill	AMES-2		$\phi 0.05 \sim \phi 0.95$	p.132
	2枚刃 標準スクエアタイプ 2-flute, Standard type	AES-2		$\phi 1.0 \sim \phi 12.0$	p.133
	2枚刃 ミニチュアロング刃長 2-flute, Miniature long flute	AMEL		$\phi 0.1 \sim \phi 0.9$	p.135
	2枚刃 ロング刃長 2-flute, Long flute type	AEL		$\phi 1.0 \sim \phi 3.0$	p.136
	4枚刃 標準タイプ 4-flute, Standard type	AES-4		$\phi 1.0 \sim \phi 12.0$	p.138
<b>ボールエンドミル Ball End Mill</b>					
ボール Ball	2枚刃 微小径ボール 2-flute Miniature Ball	AMBES-2		$R0.05 \sim R0.475$	p.139
	2枚刃 標準ボールタイプ 2-flute Ball End Mill	ABES-2		$R0.5 \sim R10$	p.140
	4枚刃 ボールタイプ 4-flute Ball End Mill	ABES-4		$R0.5 \sim R6$	p.143
<b>テーパエンドミル Taper End Mill</b>					
テーパ Taper	2枚刃 テーパーエンドミル 2-flute Taper End Mill	ATES-2		$\phi 0.1 \sim \phi 3.0$	p.144
	2枚刃 テーパーボール 2-flute Taper Ball End Mill	ATBES-2		$R0.05 \sim R1.5$	p.152
<b>その他のエンドミル Other End Mill</b>					
ラジラス Radius	ラジラスエンドミル (2枚刃) Radius End Mill, 2-flutes	AERS		$\phi 1.0 \times R0.1 \sim \phi 6 \times R2$	p.160
インナーR Inner R	コーナーRカッター (2枚刃) Inner R Cutter, 2-flutes	ACR		$R0.1 \sim R2.5$	p.161
直刃 Straight Flute	直刃タイプ (追加工用) (2枚刃) for Reforming, 2-flutes	ACSE		$\phi 1.0 \sim \phi 12.0$	p.162



型番 Model	炭素鋼 Carbon Steel	合金鋼 Alloy Steel	調質鋼 Prehardened Steel	焼入鋼 ~50HRC Hardened Steel	ステンレス鋼 Stainless Steel	アルミ合金 Aluminium Alloy	樹脂・エンブレ Resin Engineering Plastic	
AMES-2	○	○	○	—	○	◎	◎	
AES-2	○	○	○	—	○	◎	◎	
AMEL	○	○	○	—	○	◎	◎	
AEL	○	○	○	—	○	◎	◎	
AES-4	○	○	○	—	○	◎	◎	
AMBES-2	○	○	○	—	○	◎	◎	
ABES-2	○	○	○	—	○	◎	◎	
ABES-4	○	○	○	—	○	◎	◎	
ATES-2	○	○	○	—	○	◎	◎	
ATBES-2	○	○	○	—	○	◎	◎	
AERS	○	○	○	—	○	◎	◎	
ACR	○	○	○	—	○	◎	◎	
ACSE	○	○	○	—	○	○	○	

ルーマ型 (3mmシャンク)早見表 φ0.02 ~ φ0.305

単位 Unit : mm

型番 CODE NUMBER	径 Diameter φ D	刃長 Flute Length ℓ	全長 O.A.L L	詳細ページ Page
ADR & ADR-h4	0.02	0.2	38	46・59
ADR, ADR-SV, ADR-h4	0.03	0.3	38	46・67・59
ADRSL & ADRSL-SV		0.5		50・71
ADRL & ADRL-SV		0.6		52・73
ADR-SP	0.035	0.4	38	60
ADR, ADR-SV, ADR-h4	0.04	0.4	38	46・67・59
ADRSL & ADRSL-SV		0.6		50・71
ADRL & ADRL-SV		0.8		52・73
ADR-SP	0.045	0.5	38	60
ADR, ADR-SV, ADR-h4	0.05	0.5	38	46・67・59
ADRSL & ADRSL-SV		0.8		50・71
ADRL & ADRL-SV		1.1		52・73
ADR-SP	0.055	0.6	38	60
ADR, ADR-SV, ADR-h4	0.06	0.6	38	46・67・59
ADRSL & ADRSL-SV		0.8		50・71
ADRL & ADRL-SV		1.2		52・73
ADR-SP	0.065	0.7	38	60
ADR, ADR-SV, ADR-h4	0.07	0.7	38	46・67・59
ADRSL & ADRSL-SV		1.1		50・71
ADRL & ADRL-SV		1.4		52・73
ADR-SP	0.075	0.8	38	60
ADR, ADR-SV, ADR-h4	0.08	0.8	38	46・67・59
ADRSL & ADRSL-SV		1.2		50・71
ADRL & ADRL-SV		1.6		52・73
ADR-SP	0.085	0.9	38	60
ADR, ADR-SV, ADR-h4	0.09	0.9	38	46・67・59
ADRSL & ADRSL-SV		1.2		50・71
ADRL & ADRL-SV		1.8		52・73
ADR-SP	0.095	1.2	38	60
ADRS, ADRS-SV, ADR-h4	0.1	0.6	38	42・63・59
ADR & ADR-SV		1.2		46・67
ADRSL & ADRSL-SV		1.9		50・71
ADRL & ADRL-SV		2.5		52・73
ADR-SUS		1		77
ADRL-SUS	1.5	81		
ADR-SP	0.105	1.2	38	60
ADRS & ADRS-SV	0.11	0.6	38	42・63
ADR & ADR-SV		1.2		46・67
ADRSL & ADRSL-SV		1.9		50・71
ADRL & ADRL-SV		2.5		52・73
ADR-SUS		1.1		77
ADRL-SUS	1.7	81		
ADR-SP	0.115	1.4	38	60
ADRS & ADRS-SV	0.12	0.6	38	42・63

型番 CODE NUMBER	径 Diameter φ D	刃長 Flute Length ℓ	全長 O.A.L L	詳細ページ Page
ADR & ADR-SV	0.12	1.4	38	46・67
ADRSL & ADRSL-SV		2.2		50・71
ADRL & ADRL-SV		3		52・73
ADR-SUS		1.2		77
ADRL-SUS		1.8		81
ADR-SP	0.125	1.4	38	60
ADRS & ADRS-SV	0.13	0.6	38	42・63
ADR & ADR-SV		1.4		46・67
ADRSL & ADRSL-SV		2.2		50・71
ADRL & ADRL-SV		3		52・73
ADR-SUS		1.3		77
ADRL-SUS	2	81		
ADR-SP	0.135	1.4	38	60
ADRS & ADRS-SV	0.14	0.6	38	42・63
ADR & ADR-SV		1.4		46・67
ADRSL & ADRSL-SV		2.2		50・71
ADRL & ADRL-SV		3		52・73
ADR-SUS		1.4		77
ADRL-SUS	2	81		
ADR-SP	0.145	1.8	38	60
ADRS & ADRS-SV	0.15	0.8	38	42・63
ADR & ADR-SV		1.8		46・67
ADRSL & ADRSL-SV		2.9		50・71
ADRL & ADRL-SV		4		52・73
ADR-SUS		1.5		77
ADRL-SUS	2.3	81		
ADR-SP	0.155	1.8	38	60
ADRS & ADRS-SV	0.16	0.8	38	42・63
ADR & ADR-SV		1.8		46・67
ADRSL & ADRSL-SV		2.9		50・71
ADRL & ADRL-SV		4		52・73
ADR-SUS		1.5		77
ADRL-SUS	2.3	81		
ADR-SP	0.165	1.8	38	60
ADRS & ADRS-SV	0.17	0.8	38	42・63
ADR & ADR-SV		1.8		46・67
ADRSL & ADRSL-SV		3.2		50・71
ADRL & ADRL-SV		4.5		52・73
ADR-SUS		1.5		77
ADRL-SUS	2.3	81		
ADR-SP	0.175	2.1	38	60
ADRS & ADRS-SV	0.18	1	38	42・63
ADR & ADR-SV		2.1		46・67
ADRSL & ADRSL-SV		3.3		50・71

ドリル早見表 (3mmシャンク)  
Simplified Drill Size Table

単位 Unit : mm

型番 CODE NUMBER	径 Diameter φ D	刃長 Flute Length ℓ	全長 O.A.L L	詳細ページ Page
ADRL & ADRL-SV	0.18	4.5	38	52・73
ADR-SUS		1.8		77
ADRL-SUS		2.7		81
ADR-SP	0.185	2.1	38	60
ADRS & ADRS-SV	0.19	1	38	42・63
ADR & ADR-SV		2.1		46・67
ADRSL & ADRSL-SV		3.3		50・71
ADRL & ADRL-SV		4.5		52・73
ADR-SUS		1.8		77
ADRL-SUS		2.7		81
ADR-SP		0.195		2.4
ADRS & ADRS-SV	0.2	1	38	42・63
ADR & ADR-SV		2.4		46・67
ADRSL & ADRSL-SV		4		50・71
ADRL & ADRL-SV		6		52・73
ADR-SUS		2		77
ADRL-SUS		3		81
ADR-SP		0.205		2.4
ADRS & ADRS-SV	0.21	1	38	42・63
ADR & ADR-SV		2.4		46・67
ADRSL & ADRSL-SV		4		50・71
ADRL & ADRL-SV		6		52・73
ADR-SUS		2		77
ADRL-SUS		3		81
ADR-SP	0.215	2.6	38	60
ADRS & ADRS-SV	0.22	1.2	38	42・63
ADR & ADR-SV		2.6		46・67
ADRSL & ADRSL-SV		4.3		50・71
ADRL & ADRL-SV		6		52・73
ADR-SUS		2		77
ADRL-SUS		3		81
ADR-SP	0.225	2.6	38	60
ADRS & ADRS-SV	0.23	1.2	38	42・63
ADR & ADR-SV		2.6		46・67
ADRSL & ADRSL-SV		4.3		50・71
ADRL & ADRL-SV		6		52・73
ADR-SUS		2.3		77
ADRL-SUS		3.5		81
ADR-SP	0.235	2.6	38	60
ADRS & ADRS-SV	0.24	1.2	38	42・63
ADR & ADR-SV		2.6		46・67
ADRSL & ADRSL-SV		4.3		50・71
ADRL & ADRL-SV		6		52・73
ADR-SUS		2.3		77
ADRL-SUS		2.3		77

型番 CODE NUMBER	径 Diameter φ D	刃長 Flute Length ℓ	全長 O.A.L L	詳細ページ Page
ADRL-SUS	0.24	3.5	38	81
ADR-SP	0.245	3	38	60
ADRS & ADRS-SV	0.25	1.5	38	42・63
ADR & ADR-SV		3		46・67
ADRSL & ADRSL-SV		5		50・71
ADRL & ADRL-SV		7		52・73
ADR-SUS		2.5		77
ADRL-SUS	3.8	81		
ADR-SP	0.255	3	38	60
ADRS & ADRS-SV	0.26	1.5	38	42・63
ADR & ADR-SV		3		46・67
ADRSL & ADRSL-SV		5		50・71
ADRL & ADRL-SV		7		52・73
ADR-SUS		2.5		77
ADRL-SUS	3.8	81		
ADR-SP	0.265	3	38	60
ADRS & ADRS-SV	0.27	1.5	38	42・63
ADR & ADR-SV		3		46・67
ADRSL & ADRSL-SV		5		50・71
ADRL & ADRL-SV		7		52・73
ADR-SUS		2.5		77
ADRL-SUS	3.8	81		
ADR-SP	0.275	3.3	38	60
ADRS & ADRS-SV	0.28	1.5	38	42・63
ADR & ADR-SV		3.3		46・67
ADRSL & ADRSL-SV		5.2		50・71
ADRL & ADRL-SV		7		52・73
ADR-SUS		2.8		77
ADRL-SUS	4.2	81		
ADR-SP	0.285	3.3	38	60
ADRS & ADRS-SV	0.29	1.5	38	42・63
ADR & ADR-SV		3.3		46・67
ADRSL & ADRSL-SV		5.2		50・71
ADRL & ADRL-SV		7		52・73
ADR-SUS		2.8		77
ADRL-SUS	4.2	81		
ADR-SP	0.295	5	38	60
ADRS & ADRS-SV	0.3	2.5	38	42・63
ADR & ADR-SV		5		46・67
ADRSL & ADRSL-SV		7		50・71
ADRL & ADRL-SV		9		52・73
ADR-SUS		3		77
ADRL-SUS	4.5	81		
ADR-SP	0.305	5	38	60

ルーマ型 (3mmシャンク)早見表 φ0.31 ~ φ0.56

単位 Unit : mm

型番 CODE NUMBER	径 Diameter φ D	刃長 Flute Length ℓ	全長 O.A.L L	詳細ページ Page
ADRS & ADRS-SV	0.31	2.5	38	42・63
ADR & ADR-SV		5		46・67
ADRSL & ADRSL-SV		7		50・71
ADRL & ADRL-SV		9	45	52・73
ADR-SUS		3	38	77
ADRL-SUS		4.5		81
ADR-SP		0.315	5	38
ADRS & ADRS-SV	0.32	2.5	38	42・63
ADR & ADR-SV		5		46・67
ADRSL & ADRSL-SV		7		50・71
ADRL & ADRL-SV		9	45	52・73
ADR-SUS		3	38	77
ADRL-SUS		4.5		81
ADR-SP		0.325	5	38
ADRS & ADRS-SV	0.33	2.5	38	42・63
ADR & ADR-SV		5		46・67
ADRSL & ADRSL-SV		7		50・71
ADRL & ADRL-SV		9	45	52・73
ADR-SUS		3.3	38	77
ADRL-SUS		5		81
ADR-SP		0.335	5	38
ADRS & ADRS-SV	0.34	2.5	38	42・63
ADR & ADR-SV		5		46・67
ADRSL & ADRSL-SV		7		50・71
ADRL & ADRL-SV		9	45	52・73
ADR-SUS		3.3	38	77
ADRL-SUS		5		81
ADR-SP		0.345	5	38
ADRS & ADRS-SV	0.35	2.5	38	42・63
ADR & ADR-SV		5		46・67
ADRSL & ADRSL-SV		7		50・71
ADRL & ADRL-SV		10	45	52・73
ADR-SUS		3.5	38	77
ADRL-SUS		5.3		81
ADR-SP		0.355	5	38
ADRS & ADRS-SV	0.36	2.5	38	42・63
ADR & ADR-SV		5		46・67
ADRSL & ADRSL-SV		7		50・71
ADRL & ADRL-SV		10	45	52・73
ADR-SUS		3.5	38	77
ADRL-SUS		5.3		81
ADR-SP		0.365	5	38
ADRS & ADRS-SV	0.37	2.5	38	42・63
ADR & ADR-SV		5		46・67

型番 CODE NUMBER	径 Diameter φ D	刃長 Flute Length ℓ	全長 O.A.L L	詳細ページ Page
ADRSL & ADRSL-SV	0.37	7	38	50・71
ADRL & ADRL-SV		10	45	52・73
ADR-SUS		3.5	38	77
ADRL-SUS		5.3		81
ADR-SP		0.375	5	38
ADRS & ADRS-SV	0.38	2.5	38	42・63
ADR & ADR-SV		5		46・67
ADRSL & ADRSL-SV		7		50・71
ADRL & ADRL-SV		10	45	52・73
ADR-SUS		3.8	38	77
ADRL-SUS		5.7		81
ADR-SP		0.385	5	38
ADRS & ADRS-SV	0.39	2.5	38	42・63
ADR & ADR-SV		5		46・67
ADRSL & ADRSL-SV		7		50・71
ADRL & ADRL-SV		10	45	52・73
ADR-SUS		3.8	38	77
ADRL-SUS		5.7		81
ADR-SP		0.395	6	38
ADRS & ADRS-SV	0.4	3	38	42・63
ADR & ADR-SV		6		46・67
ADRSL & ADRSL-SV		9		50・71
ADRL & ADRL-SV		12	45	52・73
ADR-SUS		4	38	77
ADRL-SUS		6		81
ADR-SP		0.405	6	38
ADRS & ADRS-SV	0.41	3	38	42・63
ADR & ADR-SV		6		46・67
ADRSL & ADRSL-SV		9		50・71
ADRL & ADRL-SV		12	45	52・73
ADR-SUS		4	38	77
ADRL-SUS		6		81
ADR-SP		0.415	6	38
ADRS & ADRS-SV	0.42	3	38	42・63
ADR & ADR-SV		6		46・67
ADRSL & ADRSL-SV		9		50・71
ADRL & ADRL-SV		12	45	52・73
ADR-SUS		4	38	77
ADRL-SUS		6		81
ADR-SP		0.425	6	38
ADRS & ADRS-SV	0.43	3	38	42・63
ADR & ADR-SV		6		46・67
ADRSL & ADRSL-SV		9		50・71
ADRL & ADRL-SV		12		45

ドリル早見表 (3mmシャンク)  
Simplified Drill Size Table

単位 Unit : mm

型番 CODE NUMBER	径 Diameter φ D	刃長 Flute Length ℓ	全長 O.A.L L	詳細ページ Page
ADR-SUS	0.43	4	38	77
ADRL-SUS		6		81
ADR-SP	0.435	6	38	60
ADRS & ADRS-SV	0.44	3	38	42・63
ADR & ADR-SV		6		46・67
ADRSL & ADRSL-SV		9		50・71
ADRL & ADRL-SV		12	45	52・73
ADR-SUS		4	38	77
ADRL-SUS		6		81
ADR-SP	0.445	6	38	60
ADRS & ADRS-SV	0.45	3	38	42・63
ADR & ADR-SV		6		46・67
ADRSL & ADRSL-SV		9		50・71
ADRL & ADRL-SV		12	45	52・73
ADR-SUS		4.5	38	77
ADRL-SUS		7		81
ADR-SP	0.455	6	38	60
ADRS & ADRS-SV	0.46	3	38	42・63
ADR & ADR-SV		6		46・67
ADRSL & ADRSL-SV		9		50・71
ADRL & ADRL-SV		12	45	52・73
ADR-SUS		4.5	38	77
ADRL-SUS		7		81
ADR-SP	0.465	6	38	60
ADRS & ADRS-SV	0.47	3	38	42・63
ADR & ADR-SV		6		46・68
ADRSL & ADRSL-SV		9		51・72
ADRL & ADRL-SV		12	45	52・74
ADR-SUS		4.5	38	77
ADRL-SUS		7		81
ADR-SP	0.475	6	38	60
ADRS & ADRS-SV	0.48	3	38	42・63
ADR & ADR-SV		6		46・68
ADRSL & ADRSL-SV		9		51・72
ADRL & ADRL-SV		12	45	52・74
ADR-SUS		4.5	38	77
ADRL-SUS		7		81
ADR-SP	0.485	6	38	60
ADRS & ADRS-SV	0.49	3	38	42・63
ADR & ADR-SV		6		46・68
ADRSL & ADRSL-SV		9		51・72
ADRL & ADRL-SV		12	45	52・74
ADR-SUS		4.5	38	77
ADRL-SUS		7		81

型番 CODE NUMBER	径 Diameter φ D	刃長 Flute Length ℓ	全長 O.A.L L	詳細ページ Page
ADR-SP	0.495	6	38	60
ADRS & ADRS-SV	0.5	3	38	42・63
ADR & ADR-SV		6		46・68
ADRSL & ADRSL-SV		9		51・72
ADRL & ADRL-SV		12	45	52・74
ADR-SUS	0.5	5	38	77
ADRL-SUS		7.5		81
ADR-SP	0.505	6	38	60
ADRS & ADRS-SV	0.51	3	38	42・63
ADR & ADR-SV		6		46・68
ADRSL & ADRSL-SV		9		51・72
ADRL & ADRL-SV		12	45	52・74
ADR-SUS	0.51	5	38	77
ADRL-SUS		7.5		81
ADR-SP	0.515	6	38	61
ADRS & ADRS-SV	0.52	3	38	42・63
ADR & ADR-SV		6		46・68
ADRSL & ADRSL-SV		9		51・72
ADRL & ADRL-SV		12	45	52・74
ADR-SUS		5	38	77
ADRL-SUS		7.5		81
ADR-SP	0.525	6	38	61
ADRS & ADRS-SV	0.53	3	38	42・63
ADR & ADR-SV		6		46・68
ADRSL & ADRSL-SV		9		51・72
ADRL & ADRL-SV		12	45	52・74
ADR-SUS		5	38	77
ADRL-SUS		7.5		81
ADR-SP	0.535	6	38	61
ADRS & ADRS-SV	0.54	3	38	42・64
ADR & ADR-SV		6		47・68
ADRSL & ADRSL-SV		9		51・72
ADRL & ADRL-SV		12	45	52・74
ADR-SUS		5	38	77
ADRL-SUS		7.5		81
ADR-SP	0.545	6	38	61
ADRS & ADRS-SV	0.55	3	38	42・64
ADR & ADR-SV		6		47・68
ADRSL & ADRSL-SV		9		51・72
ADRL & ADRL-SV		12	45	53・74
ADR-SUS		5.5	38	77
ADRL-SUS		8.5		81
ADR-SP	0.555	6	38	61
ADRS & ADRS-SV	0.56	3	38	42・64

ルーマ型 (3mmシャンク)早見表 φ0.56 ~ φ0.81

単位 Unit : mm

型番 CODE NUMBER	径 Diameter φ D	刃長 Flute Length ℓ	全長 O.A.L L	詳細ページ Page
ADR & ADR-SV	0.56	6	38	47・68
ADRSL & ADRSL-SV		9		51・72
ADRL & ADRL-SV		12	45	53・74
ADR-SUS		5.5	38	77
ADRL-SUS		8.5		81
ADR-SP	0.565	6	38	61
ADRS & ADRS-SV	0.57	3	38	42・64
ADR & ADR-SV		6		47・68
ADRSL & ADRSL-SV		9	51・72	
ADRL & ADRL-SV		12	45	53・74
ADR-SUS		5.5	38	77
ADRL-SUS	8.5	81		
ADR-SP	0.575	6	38	61
ADRS & ADRS-SV	0.58	3	38	42・64
ADR & ADR-SV		6		47・68
ADRSL & ADRSL-SV		9	51・72	
ADRL & ADRL-SV		12	45	53・74
ADR-SUS		5.5	38	77
ADRL-SUS	8.5	81		
ADR-SP	0.585	6	38	61
ADRS & ADRS-SV	0.59	3	38	42・64
ADR & ADR-SV		6		47・68
ADRSL & ADRSL-SV		9	51・72	
ADRL & ADRL-SV		12	45	53・74
ADR-SUS		5.5	38	77
ADRL-SUS	8.5	81		
ADR-SP	0.595	7	38	61
ADRS & ADRS-SV	0.6	3	38	42・64
ADR & ADR-SV		7		47・68
ADRSL & ADRSL-SV		11	51・72	
ADRL & ADRL-SV		15	45	53・74
ADR-SUS		6	38	77
ADRL-SUS	9	81		
ADR-SP	0.605	7	38	61
ADRS & ADRS-SV	0.61	3	38	42・64
ADR & ADR-SV		7		47・68
ADRSL & ADRSL-SV		11	51・72	
ADRL & ADRL-SV		15	45	53・74
ADR-SUS		6	38	77
ADRL-SUS	9	81		
ADR-SP	0.615	7	38	61
ADRS & ADRS-SV	0.62	3	38	43・64
ADR & ADR-SV		7		47・68
ADRSL & ADRSL-SV		11	51・72	
ADRL & ADRL-SV		15	45	53・74

型番 CODE NUMBER	径 Diameter φ D	刃長 Flute Length ℓ	全長 O.A.L L	詳細ページ Page
ADRL & ADRL-SV	0.62	15	45	53・74
ADR-SUS		6	38	78
ADRL-SUS		9		82
ADR-SP	0.625	7	38	61
ADRS & ADRS-SV	0.63	3	38	43・64
ADR & ADR-SV		7		47・68
ADRSL & ADRSL-SV		11	51・72	
ADRL & ADRL-SV		15	45	53・74
ADR-SUS		6	38	78
ADRL-SUS	9	82		
ADR-SP	0.635	7	38	61
ADRS & ADRS-SV	0.64	3	38	43・64
ADR & ADR-SV		7		47・68
ADRSL & ADRSL-SV		11	51・72	
ADRL & ADRL-SV		15	45	53・74
ADR-SUS		6	38	78
ADRL-SUS	9	82		
ADR-SP	0.645	7	38	61
ADRS & ADRS-SV	0.65	3	38	43・64
ADR & ADR-SV		7		47・68
ADRSL & ADRSL-SV		11	51・72	
ADRL & ADRL-SV		15	45	53・74
ADR-SUS		6.5	38	78
ADRL-SUS	10	82		
ADR-SP	0.655	7	38	61
ADRS & ADRS-SV	0.66	3	38	43・64
ADR & ADR-SV		7		47・68
ADRSL & ADRSL-SV		11	51・72	
ADRL & ADRL-SV		15	45	53・74
ADR-SUS		6.5	38	78
ADRL-SUS	10	82		
ADR-SP	0.665	7	38	61
ADRS & ADRS-SV	0.67	3	38	43・64
ADR & ADR-SV		7		47・68
ADRSL & ADRSL-SV		11	51・72	
ADRL & ADRL-SV		15	45	53・74
ADR-SUS		6.5	38	78
ADRL-SUS	10	82		
ADR-SP	0.675	7	38	61
ADRS & ADRS-SV	0.68	3	38	43・64
ADR & ADR-SV		7		47・68
ADRSL & ADRSL-SV		11	51・72	
ADRL & ADRL-SV		15	45	53・74
ADR-SUS	6.5	38	78	

ドリル早見表 (3mm シャンク)  
Simplified Drill Size Table

単位 Unit : mm

型番 CODE NUMBER	径 Diameter φ D	刃長 Flute Length ℓ	全長 O.A.L L	詳細ページ Page
ADRL-SUS	0.68	10	38	82
ADR-SP	0.685	7	38	61
ADRS & ADRS-SV	0.69	3	38	43・64
ADR & ADR-SV		7		47・68
ADRSL & ADRSL-SV		11		51・72
ADRL & ADRL-SV		15	45	53・74
ADR-SUS		6.5	38	78
ADRL-SUS		10		82
ADR-SP	0.695	8	38	61
ADRS & ADRS-SV	0.7	4	38	43・64
ADR & ADR-SV		8		47・68
ADRSL & ADRSL-SV		11		51・72
ADRL & ADRL-SV		15	45	53・74
ADR-SUS		7	38	78
ADRL-SUS		10.5		82
ADR-SP	0.705	8	38	61
ADRS & ADRS-SV	0.71	4	38	43・64
ADR & ADR-SV		8		47・68
ADRSL & ADRSL-SV		11		51・72
ADRL & ADRL-SV		15	45	53・74
ADR-SUS		7	38	78
ADRL-SUS		10.5		82
ADR-SP	0.715	8	38	61
ADRS & ADRS-SV	0.72	4	38	43・64
ADR & ADR-SV		8		47・68
ADRSL & ADRSL-SV		11		51・72
ADRL & ADRL-SV		15	45	53・74
ADR-SUS		7	38	78
ADRL-SUS		10.5		82
ADR-SP	0.725	8	38	61
ADRS & ADRS-SV	0.73	4	38	43・64
ADR & ADR-SV		8		47・68
ADRSL & ADRSL-SV		11		51・72
ADRL & ADRL-SV		15	45	53・74
ADR-SUS		7	38	78
ADRL-SUS		10.5		82
ADR-SP	0.735	8	38	61
ADRS & ADRS-SV	0.74	4	38	43・64
ADR & ADR-SV		8		47・68
ADRSL & ADRSL-SV		11		51・72
ADRL & ADRL-SV		15	45	53・74
ADR-SUS		7	38	78
ADRL-SUS		10.5		82
ADR-SP	0.745	8	38	61

型番 CODE NUMBER	径 Diameter φ D	刃長 Flute Length ℓ	全長 O.A.L L	詳細ページ Page
ADRS & ADRS-SV	0.75	4	38	43・64
ADR & ADR-SV		8		47・68
ADRSL & ADRSL-SV		11		51・72
ADRL & ADRL-SV		15	45	53・74
ADR-SUS		7.5	38	78
ADRL-SUS	11.5	82		
ADR-SP	0.755	8	38	61
ADRS & ADRS-SV	0.76	4	38	43・64
ADR & ADR-SV		8		47・68
ADRSL & ADRSL-SV		11		51・72
ADRL & ADRL-SV		15	45	53・74
ADR-SUS		7.5	38	78
ADRL-SUS	11.5	82		
ADR-SP	0.765	8	38	61
ADRS & ADRS-SV	0.77	4	38	43・64
ADR & ADR-SV		8		47・68
ADRSL & ADRSL-SV		11		51・72
ADRL & ADRL-SV		15	45	53・74
ADR-SUS		7.5	38	78
ADRL-SUS	11.5	82		
ADR-SP	0.775	8	38	61
ADRS & ADRS-SV	0.78	4	38	43・64
ADR & ADR-SV		8		47・68
ADRSL & ADRSL-SV		11		51・72
ADRL & ADRL-SV		15	45	53・74
ADR-SUS		7.5	38	78
ADRL-SUS	11.5	82		
ADR-SP	0.785	8	38	61
ADRS & ADRS-SV	0.79	4	38	43・64
ADR & ADR-SV		8		47・68
ADRSL & ADRSL-SV		11		51・72
ADRL & ADRL-SV		15	45	53・74
ADR-SUS		7.5	38	78
ADRL-SUS	11.5	82		
ADR-SP	0.795	8	38	61
ADRS & ADRS-SV	0.8	4	38	43・64
ADR & ADR-SV		8		47・68
ADRSL & ADRSL-SV		11		51・72
ADRL & ADRL-SV		15	45	53・74
ADR-SUS		8	38	78
ADRL-SUS	12.5	82		
ADR-SP	0.805	8	38	61
ADRS & ADRS-SV	0.81	4	38	43・64
ADR & ADR-SV		8		47・68

ルーマ型 (3mmシャンク)早見表 φ0.81 ~ φ1.07

単位 Unit : mm

型番 CODE NUMBER	径 Diameter φ D	刃長 Flute Length ℓ	全長 O.A.L L	詳細ページ Page
ADRSL & ADRSL-SV	0.81	11	38	51・72
ADRL & ADRL-SV		15	45	53・74
ADR-SUS		8	38	78
ADRL-SUS		12.5	45	82
ADR-SP	0.815	8	38	61
ADRS & ADRS-SV	0.82	4		43・64
ADR & ADR-SV		8	38	47・68
ADRSL & ADRSL-SV		11		51・72
ADRL & ADRL-SV		15	45	53・74
ADR-SUS		8	38	78
ADRL-SUS		12.5	45	82
ADR-SP	0.825	8	38	61
ADRS & ADRS-SV	0.83	4		43・64
ADR & ADR-SV		8	38	47・68
ADRSL & ADRSL-SV		11		51・72
ADRL & ADRL-SV		15	45	53・74
ADR-SUS		8	38	78
ADRL-SUS		12.5	45	82
ADR-SP	0.835	8	38	61
ADRS & ADRS-SV	0.84	4		43・64
ADR & ADR-SV		8	38	47・68
ADRSL & ADRSL-SV		11		51・72
ADRL & ADRL-SV		15	45	53・74
ADR-SUS		8	38	78
ADRL-SUS		12.5	45	82
ADR-SP	0.845	8	38	61
ADRS & ADRS-SV	0.85	4		43・64
ADR & ADR-SV		8	38	47・68
ADRSL & ADRSL-SV		11		51・72
ADRL & ADRL-SV		15	45	53・74
ADR-SUS		8	38	78
ADRL-SUS		12.5	45	82
ADR-SP	0.855	8	38	61
ADRS & ADRS-SV	0.86	4		43・64
ADR & ADR-SV		8	38	47・68
ADRSL & ADRSL-SV		11		51・72
ADRL & ADRL-SV		15	45	53・74
ADR-SUS		8	38	78
ADRL-SUS		12.5	45	82
ADR-SP	0.865	8	38	61
ADRS & ADRS-SV	0.87	4		43・64
ADR & ADR-SV		8	38	47・68
ADRSL & ADRSL-SV		11		51・72
ADRL & ADRL-SV		15	45	53・74

型番 CODE NUMBER	径 Diameter φ D	刃長 Flute Length ℓ	全長 O.A.L L	詳細ページ Page
ADR-SUS	0.87	8	38	78
ADRL-SUS		12.5	45	82
ADR-SP	0.875	8	38	61
ADRS & ADRS-SV	0.88	4		43・64
ADR & ADR-SV		8	38	47・68
ADRSL & ADRSL-SV		11		51・72
ADRL & ADRL-SV		15	45	53・74
ADR-SUS		8	38	78
ADRL-SUS		12.5	45	82
ADR-SP	0.885	8	38	61
ADRS & ADRS-SV	0.89	4		43・64
ADR & ADR-SV		8	38	47・68
ADRSL & ADRSL-SV		11		51・72
ADRL & ADRL-SV		15	45	53・74
ADR-SUS		8	38	78
ADRL-SUS		12.5	45	82
ADR-SP	0.895	8	38	61
ADRS & ADRS-SV	0.9	4		43・64
ADR & ADR-SV		8	38	47・68
ADRSL & ADRSL-SV		11		51・72
ADRL & ADRL-SV		15	45	53・74
ADR-SUS		9	38	78
ADRL-SUS		14	45	82
ADR-SP	0.905	8	38	61
ADRS & ADRS-SV	0.91	4		43・64
ADR & ADR-SV		8	38	47・68
ADRSL & ADRSL-SV		11		51・72
ADRL & ADRL-SV		15	45	53・74
ADR-SUS		9	38	78
ADRL-SUS		14	45	82
ADR-SP	0.915	8	38	61
ADRS & ADRS-SV	0.92	4		43・64
ADR & ADR-SV		8	38	47・68
ADRSL & ADRSL-SV		11		51・72
ADRL & ADRL-SV		15	45	53・74
ADR-SUS		9	38	78
ADRL-SUS		14	45	82
ADR-SP	0.925	8	38	61
ADRS & ADRS-SV	0.93	4		43・64
ADR & ADR-SV		8	38	47・68
ADRSL & ADRSL-SV		11		51・72
ADRL & ADRL-SV		15	45	53・74
ADR-SUS		9	38	78
ADRL-SUS		14	45	82

ドリル早見表 (3mmシャンク)  
Simplified Drill Size Table



単位 Unit : mm

型番 CODE NUMBER	径 Diameter φ D	刃長 Flute Length ℓ	全長 O.A.L L	詳細ページ Page
ADR-SP	0.935	8	38	61
ADRS & ADRS-SV	0.94	4	38	43・64
ADR & ADR-SV		8		47・68
ADRSL & ADRSL-SV		11	51・72	
ADRL & ADRL-SV		15	45	53・74
ADR-SUS		9	38	78
ADRL-SUS		14	45	82
ADR-SP		0.945	8	38
ADRS & ADRS-SV	0.95	4	38	43・64
ADR & ADR-SV		8		47・68
ADRSL & ADRSL-SV		11	51・72	
ADRL & ADRL-SV		15	45	53・74
ADR-SUS		9	38	78
ADRL-SUS		14	45	82
ADR-SP		0.955	8	38
ADRS & ADRS-SV	0.96	4	38	43・64
ADR & ADR-SV		8		47・68
ADRSL & ADRSL-SV		11	51・72	
ADRL & ADRL-SV		15	45	53・74
ADR-SUS		9	38	78
ADRL-SUS		14	45	82
ADR-SP		0.965	8	38
ADRS & ADRS-SV	0.97	4	38	43・64
ADR & ADR-SV		8		47・68
ADRSL & ADRSL-SV		11	51・72	
ADRL & ADRL-SV		15	45	53・74
ADR-SUS		9	38	78
ADRL-SUS		14	45	82
ADR-SP		0.975	8	38
ADRS & ADRS-SV	0.98	4	38	43・64
ADR & ADR-SV		8		47・68
ADRSL & ADRSL-SV		11	51・72	
ADRL & ADRL-SV		15	45	53・74
ADR-SUS		9	38	78
ADRL-SUS		14	45	82
ADR-SP		0.985	8	38
ADRS & ADRS-SV	0.99	4	38	43・64
ADR & ADR-SV		8		47・68
ADRSL & ADRSL-SV		11	51・72	
ADRL & ADRL-SV		15	45	53・74
ADR-SUS		9	38	78
ADRL-SUS		14	45	82
ADR-SP		0.995	10	38
ADRS & ADRS-SV	1	5	38	43・64

型番 CODE NUMBER	径 Diameter φ D	刃長 Flute Length ℓ	全長 O.A.L L	詳細ページ Page
ADR & ADR-SV	1	10	38	47・68
ADRSL & ADRSL-SV		15	45	51・72
ADRL & ADRL-SV		20	50	53・74
ADR-SUS		10	38	78
ADRL-SUS		15	45	82
ADR-SP	1.005	10	38	61
ADRS & ADRS-SV	1.01	5	38	43・64
ADR & ADR-SV		10		47・68
ADRL & ADRL-SV		20	50	53・74
ADR-SUS		10	38	78
ADRL-SUS		15	45	82
ADR-SP	1.015	10	38	61
ADRS & ADRS-SV	1.02	5	38	43・64
ADR & ADR-SV		10		47・68
ADRL & ADRL-SV		20	50	53・74
ADR-SUS		10	38	78
ADRL-SUS		15	45	82
ADR-SP	1.025	10	38	61
ADRS & ADRS-SV	1.03	5	38	43・64
ADR & ADR-SV		10		47・68
ADRL & ADRL-SV		20	50	53・74
ADR-SUS		10	38	78
ADRL-SUS		15	45	82
ADR-SP	1.035	10	38	61
ADRS & ADRS-SV	1.04	5	38	43・64
ADR & ADR-SV		10		47・68
ADRL & ADRL-SV		20	50	53・74
ADR-SUS		10	38	78
ADRL-SUS		15	45	82
ADR-SP	1.045	10	38	61
ADRS & ADRS-SV	1.05	5	38	43・64
ADR & ADR-SV		10		47・68
ADRSL & ADRSL-SV		15	45	51・72
ADRL & ADRL-SV		20	50	53・74
ADR-SUS		10	38	78
ADRL-SUS	15	45	82	
ADR-SP	1.055	10	38	61
ADRS & ADRS-SV	1.06	5	38	43・64
ADR & ADR-SV		10		47・68
ADRL & ADRL-SV		20	50	53・74
ADR-SUS		10	38	78
ADRL-SUS		15	45	82
ADR-SP	1.065	10	38	61
ADRS & ADRS-SV	1.07	5	38	43・64

ルーマ型 (3mmシャンク)早見表 φ1.07~φ1.35

単位 Unit : mm

型番 CODE NUMBER	径 Diameter φ D	刃長 Flute Length ℓ	全長 O.A.L L	詳細ページ Page
ADR & ADR-SV	1.07	10	38	47・68
ADRL & ADRL-SV		20	50	53・74
ADR-SUS		10	38	78
ADRL-SUS		15	45	82
ADR-SP	1.075	10	38	61
ADRS & ADRS-SV	1.08	5	38	43・64
ADR & ADR-SV		10		47・68
ADRL & ADRL-SV		20	50	53・74
ADR-SUS		10	38	78
ADRL-SUS		15	45	82
ADR-SP	1.085	10	38	61
ADRS & ADRS-SV	1.09	5	38	43・64
ADR & ADR-SV		10		47・68
ADRL & ADRL-SV		20	50	53・74
ADR-SUS		10	38	78
ADRL-SUS		15	45	82
ADR-SP	1.095	10	38	61
ADRS & ADRS-SV	1.1	5	38	43・64
ADR & ADR-SV		10		47・68
ADRSL & ADRSL-SV		15	45	51・72
ADRL & ADRL-SV		20	50	53・74
ADR-SUS		10	38	78
ADRL-SUS		15	45	82
ADR-SP	1.105	10	38	61
ADRS & ADRS-SV	1.11	5	38	43・64
ADR & ADR-SV		10		47・68
ADRL & ADRL-SV		20	50	53・74
ADR-SUS		10	38	78
ADRL-SUS		15	45	82
ADR-SP	1.115	10	38	61
ADRS & ADRS-SV	1.12	5	38	43・64
ADR & ADR-SV		10		47・68
ADRL & ADRL-SV		20	50	53・74
ADR-SUS		10	38	78
ADRL-SUS		15	45	82
ADR-SP	1.125	10	38	61
ADRS & ADRS-SV	1.13	5	38	43・64
ADR & ADR-SV		10		47・68
ADRL & ADRL-SV		20	50	53・74
ADR-SUS		10	38	78
ADRL-SUS		15	45	82
ADR-SP	1.135	10	38	61
ADRS & ADRS-SV	1.14	5	38	43・64
ADR & ADR-SV		10		47・68

型番 CODE NUMBER	径 Diameter φ D	刃長 Flute Length ℓ	全長 O.A.L L	詳細ページ Page
ADRL & ADRL-SV	1.14	20	50	53・74
ADR-SUS		10	38	78
ADRL-SUS		15	45	82
ADR-SP	1.145	10	38	61
ADRS & ADRS-SV	1.15	5	38	43・64
ADR & ADR-SV		10		47・68
ADRSL & ADRSL-SV		15	45	51・72
ADRL & ADRL-SV		20	50	53・74
ADR-SUS		10	38	78
ADRL-SUS		15	45	82
ADR-SP	1.155	10	38	61
ADRS & ADRS-SV	1.16	5	38	43・64
ADR & ADR-SV		10		47・68
ADRL & ADRL-SV		20	50	53・74
ADR-SUS		10	38	78
ADRL-SUS		15	45	82
ADR-SP	1.165	10	38	61
ADRS & ADRS-SV	1.17	5	38	43・64
ADR & ADR-SV		10		47・68
ADRL & ADRL-SV		20	50	53・74
ADR-SUS		10	38	78
ADRL-SUS		15	45	82
ADR-SP	1.175	10	38	61
ADRS & ADRS-SV	1.18	5	38	43・64
ADR & ADR-SV		10		47・68
ADRL & ADRL-SV		20	50	53・74
ADR-SUS		10	38	78
ADRL-SUS		15	45	82
ADR-SP	1.185	10	38	61
ADRS & ADRS-SV	1.19	5	38	43・64
ADR & ADR-SV		10		47・68
ADRL & ADRL-SV		20	50	53・74
ADR-SUS		10	38	78
ADRL-SUS		15	45	82
ADR-SP	1.195	10	38	61
ADRS & ADRS-SV	1.2	5	38	43・64
ADR & ADR-SV		10		47・68
ADRSL & ADRSL-SV		15	45	51・72
ADRL & ADRL-SV		20	50	53・74
ADR-SUS		10	38	78
ADRL-SUS		15	45	82
ADR-SP	1.205	10	38	61
ADRS & ADRS-SV	1.21	5	38	43・64
ADR & ADR-SV		10		47・68

ドリル早見表 (3mmシャンク)  
Simplified Drill Size Table

単位 Unit : mm

型番 CODE NUMBER	径 Diameter φ D	刃長 Flute Length ℓ	全長 O.A.L L	詳細ページ Page
ADRL & ADRL-SV	1.21	20	50	53・74
ADR-SUS		10	38	78
ADRL-SUS		15	45	82
ADR-SP	1.215	10	38	61
ADRS & ADRS-SV	1.22	5	38	43・64
ADR & ADR-SV		10		47・68
ADRL & ADRL-SV		20	50	53・74
ADR-SUS		10	38	78
ADRL-SUS		15	45	82
ADR-SP	1.225	10	38	61
ADRS & ADRS-SV	1.23	5	38	43・64
ADR & ADR-SV		10		47・68
ADRL & ADRL-SV		20	50	53・74
ADR-SUS		10	38	78
ADRL-SUS		15	45	82
ADR-SP	1.235	10	38	61
ADRS & ADRS-SV	1.24	5	38	43・64
ADR & ADR-SV		10		47・68
ADRL & ADRL-SV		20	50	53・74
ADR-SUS		10	38	78
ADRL-SUS		15	45	82
ADR-SP	1.245	10	38	61
ADRS & ADRS-SV	1.25	5	38	43・64
ADR & ADR-SV		10		47・68
ADRSL & ADRSL-SV		15	45	51・72
ADRL & ADRL-SV		20	50	53・74
ADR-SUS		10	38	78
ADRL-SUS	15	45	82	
ADR-SP	1.255	10	38	61
ADRS & ADRS-SV	1.26	5	38	43・64
ADR & ADR-SV		10		47・68
ADRL & ADRL-SV		20	50	53・74
ADR-SUS		10	38	78
ADRL-SUS		15	45	82
ADR-SP	1.265	10	38	61
ADRS & ADRS-SV	1.27	5	38	43・64
ADR & ADR-SV		10		47・68
ADRL & ADRL-SV		20	50	53・74
ADR-SUS		10	38	78
ADRL-SUS		15	45	82
ADR-SP	1.275	10	38	61
ADRS & ADRS-SV	1.28	5	38	43・64
ADR & ADR-SV		10		47・68
ADRL & ADRL-SV		20	50	53・74

型番 CODE NUMBER	径 Diameter φ D	刃長 Flute Length ℓ	全長 O.A.L L	詳細ページ Page
ADR-SUS	1.28	10	38	78
ADRL-SUS		15	45	82
ADR-SP	1.285	10	38	61
ADRS & ADRS-SV	1.29	5	38	43・64
ADR & ADR-SV		10		47・68
ADRL & ADRL-SV		20	50	53・74
ADR-SUS		10	38	78
ADRL-SUS		15	45	82
ADR-SP	1.295	10	38	61
ADRS & ADRS-SV	1.3	5	38	43・64
ADR & ADR-SV		10		47・68
ADRSL & ADRSL-SV		18	45	51・72
ADRL & ADRL-SV		25	60	53・74
ADR-SUS		10	38	78
ADRL-SUS	17	45	82	
ADR-SP	1.305	10	38	61
ADRS & ADRS-SV	1.31	5	38	43・64
ADR & ADR-SV		10		47・68
ADRL & ADRL-SV		25	60	53・74
ADR-SUS		10	38	78
ADRL-SUS		17	45	82
ADR-SP	1.315	10	38	61
ADRS & ADRS-SV	1.32	5	38	43・64
ADR & ADR-SV		10		47・68
ADRL & ADRL-SV		25	60	53・74
ADR-SUS		10	38	78
ADRL-SUS		17	45	82
ADR-SP	1.325	10	38	61
ADRS & ADRS-SV	1.33	5	38	43・64
ADR & ADR-SV		10		47・68
ADRL & ADRL-SV		25	60	53・74
ADR-SUS		10	38	78
ADRL-SUS		17	45	82
ADR-SP	1.335	10	38	61
ADRS & ADRS-SV	1.34	5	38	43・64
ADR & ADR-SV		10		47・68
ADRL & ADRL-SV		25	60	53・74
ADR-SUS		10	38	78
ADRL-SUS		17	45	82
ADR-SP	1.345	10	38	61
ADRS & ADRS-SV	1.35	5	38	43・64
ADR & ADR-SV		10		47・69
ADRSL & ADRSL-SV		18	45	51・72
ADRL & ADRL-SV		25	60	53・75

ルーマ型 (3mmシャンク)早見表 φ1.35 ~ φ1.63

単位 Unit : mm

型番 CODE NUMBER	径 Diameter φ D	刃長 Flute Length ℓ	全長 O.A.L L	詳細ページ Page
ADR-SUS	1.35	10	38	78
ADRL-SUS		17	45	82
ADR-SP	1.355	10	38	61
ADRS & ADRS-SV	1.36	5	38	43・64
ADR & ADR-SV		10		47・69
ADRL & ADRL-SV		25	60	53・75
ADR-SUS		10	38	78
ADRL-SUS	1.365	17	45	82
ADR-SP		10	38	61
ADRS & ADRS-SV	1.37	5	38	43・64
ADR & ADR-SV		10		47・69
ADRL & ADRL-SV		25	60	53・75
ADR-SUS		10	38	78
ADRL-SUS	1.375	17	45	82
ADR-SP		10	38	61
ADRS & ADRS-SV	1.38	5	38	43・64
ADR & ADR-SV		10		47・69
ADRL & ADRL-SV		25	60	53・75
ADR-SUS		10	38	78
ADRL-SUS	1.385	17	45	82
ADR-SP		10	38	61
ADRS & ADRS-SV	1.39	5	38	43・64
ADR & ADR-SV		10		47・69
ADRL & ADRL-SV		25	60	53・75
ADR-SUS		10	38	78
ADRL-SUS	1.395	17	45	82
ADR-SP		10	38	62
ADRS & ADRS-SV	1.4	5	38	43・64
ADR & ADR-SV		10		47・69
ADRSL & ADRSL-SV		18	45	51・72
ADRL & ADRL-SV		25	60	53・75
ADR-SUS	1.405	10	38	78
ADRL-SUS		17	45	82
ADR-SP	1.41	10	38	62
ADRS & ADRS-SV		5	38	43・64
ADR & ADR-SV		10		47・69
ADRL & ADRL-SV		25	60	53・75
ADR-SUS	1.415	10	38	78
ADRL-SUS		17	45	82
ADR-SP	1.42	10	38	62
ADRS & ADRS-SV		5	38	43・65
ADR & ADR-SV		10		48・69
ADRL & ADRL-SV		25	60	53・75
ADR-SUS	1.425	10	38	78
ADRL-SUS		17	45	82

型番 CODE NUMBER	径 Diameter φ D	刃長 Flute Length ℓ	全長 O.A.L L	詳細ページ Page
ADRL-SUS	1.42	17	45	82
ADR-SP	1.425	10	38	62
ADRS & ADRS-SV	1.43	5	38	43・65
ADR & ADR-SV		10		48・69
ADRL & ADRL-SV		25	60	54・75
ADR-SUS		10	38	78
ADRL-SUS	1.435	17	45	82
ADR-SP		10	38	62
ADRS & ADRS-SV	1.44	5	38	43・65
ADR & ADR-SV		10		48・69
ADRL & ADRL-SV		25	60	54・75
ADR-SUS		10	38	78
ADRL-SUS	1.445	17	45	82
ADR-SP		10	38	62
ADRS & ADRS-SV	1.45	5	38	43・65
ADR & ADR-SV		10		48・69
ADRSL & ADRSL-SV		18	45	51・72
ADRL & ADRL-SV		25	60	54・75
ADR-SUS	1.455	10	38	78
ADRL-SUS		17	45	82
ADR-SP	1.455	10	38	62
ADRS & ADRS-SV	1.46	5	38	43・65
ADR & ADR-SV		10		48・69
ADRL & ADRL-SV		25	60	54・75
ADR-SUS		10	38	78
ADRL-SUS	1.465	17	45	82
ADR-SP		10	38	62
ADRS & ADRS-SV	1.47	5	38	43・65
ADR & ADR-SV		10		48・69
ADRL & ADRL-SV		25	60	54・75
ADR-SUS		10	38	78
ADRL-SUS	1.475	17	45	82
ADR-SP		10	38	62
ADRS & ADRS-SV	1.48	5	38	43・65
ADR & ADR-SV		10		48・69
ADRL & ADRL-SV		25	60	54・75
ADR-SUS		10	38	78
ADRL-SUS	1.485	17	45	82
ADR-SP		10	38	62
ADRS & ADRS-SV	1.49	5	38	43・65
ADR & ADR-SV		10		48・69
ADRL & ADRL-SV		25	60	54・75
ADR-SUS		10	38	78
ADRL-SUS	1.495	17	45	82
ADR-SP		10	38	62

ドリル早見表 (3mmシャンク)  
Simplified Drill Size Table

単位 Unit : mm

型番 CODE NUMBER	径 Diameter φ D	刃長 Flute Length ℓ	全長 O.A.L L	詳細ページ Page	
ADR-SP	1.495	10	38	62	
ADRS & ADRS-SV	1.5	5	38	44・65	
ADR & ADR-SV		10		48・69	
ADRSL & ADRSL-SV		18	45	51・72	
ADRL & ADRL-SV		25	60	54・75	
ADR-SUS		10	38	79	
ADRL-SUS		17	45	83	
ADR-SP		1.505	10	38	62
ADRS & ADRS-SV	1.51	5	38	44・65	
ADR & ADR-SV		10		48・69	
ADRL & ADRL-SV		25	60	54・75	
ADR-SUS		10	38	79	
ADRL-SUS		17	45	83	
ADR-SP		1.515	10	38	62
ADRS & ADRS-SV		1.52	5	38	44・65
ADR & ADR-SV	10		48・69		
ADRL & ADRL-SV	25		60	54・75	
ADR-SUS	10		38	79	
ADRL-SUS	17		45	83	
ADR-SP	1.525		10	38	62
ADRS & ADRS-SV	1.53		5	38	44・65
ADR & ADR-SV		10	48・69		
ADRL & ADRL-SV		25	60	54・75	
ADR-SUS		10	38	79	
ADRL-SUS		17	45	83	
ADR-SP		1.535	10	38	62
ADRS & ADRS-SV		1.54	5	38	44・65
ADR & ADR-SV	10		48・69		
ADRL & ADRL-SV	25		60	54・75	
ADR-SUS	10		38	79	
ADRL-SUS	17		45	83	
ADR-SP	1.545		10	38	62
ADRS & ADRS-SV	1.55		5	38	44・65
ADR & ADR-SV		10	48・69		
ADRSL & ADRSL-SV		18	45	51・72	
ADRL & ADRL-SV		25	60	54・75	
ADR-SUS		10	38	79	
ADRL-SUS		17	45	83	
ADR-SP		1.555	10	38	62
ADRS & ADRS-SV	1.56	5	38	44・65	
ADR & ADR-SV		10		48・69	
ADRL & ADRL-SV		25	60	54・75	
ADR-SUS		10	38	79	
ADRL-SUS		17	45	83	

型番 CODE NUMBER	径 Diameter φ D	刃長 Flute Length ℓ	全長 O.A.L L	詳細ページ Page	
ADR-SP	1.565	10	38	62	
ADRS & ADRS-SV	1.57	5	38	44・65	
ADR & ADR-SV		10		48・69	
ADRL & ADRL-SV		25	60	54・75	
ADR-SUS		10	38	79	
ADRL-SUS		17	45	83	
ADR-SP		1.575	10	38	62
ADRS & ADRS-SV		1.58	5	38	44・65
ADR & ADR-SV	10		48・69		
ADRL & ADRL-SV	25		60	54・75	
ADR-SUS	10		38	79	
ADRL-SUS	17		45	83	
ADR-SP	1.585		10	38	62
ADRS & ADRS-SV	1.59		5	38	44・65
ADR & ADR-SV		10	48・69		
ADRL & ADRL-SV		25	60	54・75	
ADR-SUS		10	38	79	
ADRL-SUS		17	45	83	
ADR-SP		1.595	22	50	62
ADRS & ADRS-SV		1.6	10	38	44・65
ADR	22		50	48	
ADR-SV	16		45	69	
ADRSL & ADRSL-SV	27		60	51・72	
ADRL & ADRL-SV	32			54・75	
ADR-SUS	12		45	79	
ADRL-SUS	20		50	83	
ADR-SP	1.605	22	50	62	
ADRS & ADRS-SV	1.61	10	38	44・65	
ADR		22	50	48	
ADR-SV		16	45	69	
ADRL & ADRL-SV		32	60	54・75	
ADR-SUS		12	45	79	
ADRL-SUS		20	50	83	
ADR-SP		1.615	22	50	62
ADRS & ADRS-SV	1.62	10	38	44・65	
ADR		22	50	48	
ADR-SV		16	45	69	
ADRL & ADRL-SV		32	60	54・75	
ADR-SUS		12	45	79	
ADRL-SUS		20	50	83	
ADR-SP		1.625	22	50	62
ADRS & ADRS-SV	1.63	10	38	44・65	
ADR		22	50	48	
ADR-SV		16	45	69	

## ルーマ型 (3mmシャンク)早見表 φ1.63~φ1.87

単位 Unit : mm

型番 CODE NUMBER	径 Diameter φ D	刃長 Flute Length ℓ	全長 O.A.L L	詳細ページ Page	
ADRL & ADRL-SV	1.63	32	60	54・75	
ADR-SUS		12	45	79	
ADRL-SUS		20	50	83	
ADR-SP	1.635	22	50	62	
ADRS & ADRS-SV	1.64	10	38	44・65	
ADR		22	50	48	
ADR-SV		16	45	69	
ADRL & ADRL-SV		32	60	54・75	
ADR-SUS		12	45	79	
ADRL-SUS		20	50	83	
ADR-SP	1.645	22	50	62	
ADRS & ADRS-SV	1.65	10	38	44・65	
ADR		22	50	48	
ADR-SV		16	45	69	
ADRS & ADRS-SV		27	60	51・72	
ADRL & ADRL-SV		32	60	54・75	
ADR-SUS		12	45	79	
ADRL-SUS		20	50	83	
ADR-SP		1.655	22	50	62
ADRS & ADRS-SV		1.66	10	38	44・65
ADR			22	50	48
ADR-SV	16		45	69	
ADRL & ADRL-SV	32		60	54・75	
ADR-SUS	12		45	79	
ADRL-SUS	20		50	83	
ADR-SP	1.665	22	50	62	
ADRS & ADRS-SV	1.67	10	38	44・65	
ADR		22	50	48	
ADR-SV		16	45	69	
ADRL & ADRL-SV		32	60	54・75	
ADR-SUS		12	45	79	
ADRL-SUS		20	50	83	
ADR-SP		1.675	22	50	62
ADRS & ADRS-SV	1.68	10	38	44・65	
ADR		22	50	48	
ADR-SV		16	45	69	
ADRL & ADRL-SV		32	60	54・75	
ADR-SUS		12	45	79	
ADRL-SUS		20	50	83	
ADR-SP		1.685	22	50	62
ADRS & ADRS-SV		1.69	10	38	44・65
ADR	22		50	48	
ADR-SV	16		45	69	
ADRL & ADRL-SV	32		60	54・75	

型番 CODE NUMBER	径 Diameter φ D	刃長 Flute Length ℓ	全長 O.A.L L	詳細ページ Page	
ADR-SUS	1.69	12	45	79	
ADRL-SUS		20	50	83	
ADR-SP	1.695	22	50	62	
ADRS & ADRS-SV	1.7	10	38	44・65	
ADR		22	50	48	
ADR-SV		16	45	69	
ADRS & ADRS-SV		27	60	51・72	
ADRL & ADRL-SV		32	60	54・75	
ADR-SUS		12	45	79	
ADRL-SUS		20	50	83	
ADR-SP		1.705	22	50	62
ADRS & ADRS-SV		1.71	10	38	44・65
ADR			22	50	48
ADR-SV	16		45	69	
ADRL & ADRL-SV	32		60	54・75	
ADR-SUS	12		45	79	
ADRL-SUS	20		50	83	
ADR-SP	1.715	22	50	62	
ADRS & ADRS-SV	1.72	10	38	44・65	
ADR		22	50	48	
ADR-SV		16	45	69	
ADRL & ADRL-SV		32	60	54・75	
ADR-SUS		12	45	79	
ADRL-SUS		20	50	83	
ADR-SP	1.725	22	50	62	
ADRS & ADRS-SV	1.73	10	38	44・65	
ADR		22	50	48	
ADR-SV		16	45	69	
ADRL & ADRL-SV		32	60	54・75	
ADR-SUS		12	45	79	
ADRL-SUS		20	50	83	
ADR-SP		1.735	22	50	62
ADRS & ADRS-SV	1.74	10	38	44・65	
ADR		22	50	48	
ADR-SV		16	45	69	
ADRL & ADRL-SV		32	60	54・75	
ADR-SUS		12	45	79	
ADRL-SUS		20	50	83	
ADR-SP	1.745	22	50	62	
ADRS & ADRS-SV	1.75	10	38	44・65	
ADR		22	50	48	
ADR-SV		16	45	69	
ADRS & ADRS-SV		27	60	51・72	
ADRL & ADRL-SV		32	60	54・75	

ドリル早見表 (3mmシャンク)  
Simplified Drill Size Table

単位 Unit : mm

型番 CODE NUMBER	径 Diameter φ D	刃長 Flute Length ℓ	全長 O.A.L L	詳細ページ Page
ADR-SUS	1.75	12	45	79
ADRL-SUS		20	50	83
ADR-SP	1.755	22	50	62
ADRS & ADRS-SV	1.76	10	38	44・65
ADR		22	50	48
ADR-SV		16	45	69
ADRL & ADRL-SV		32	60	54・75
ADR-SUS		12	45	79
ADRL-SUS		20	50	83
ADR-SP		1.765	22	50
ADRS & ADRS-SV	1.77	10	38	44・65
ADR		22	50	48
ADR-SV		16	45	69
ADRL & ADRL-SV		32	60	54・75
ADR-SUS		12	45	79
ADRL-SUS		20	50	83
ADR-SP		1.775	22	50
ADRS & ADRS-SV	1.78	10	38	44・65
ADR		22	50	48
ADR-SV		16	45	69
ADRL & ADRL-SV		32	60	54・75
ADR-SUS		12	45	79
ADRL-SUS		20	50	83
ADR-SP		1.785	22	50
ADRS & ADRS-SV	1.79	10	38	44・65
ADR		22	50	48
ADR-SV		16	45	69
ADRL & ADRL-SV		32	60	54・75
ADR-SUS		12	45	79
ADRL-SUS		20	50	83
ADR-SP		1.795	22	50
ADRS & ADRS-SV	1.8	10	38	44・65
ADR		22	50	48
ADR-SV		16	45	69
ADRSL & ADRSL-SV		27	60	51・72
ADRL & ADRL-SV		32	60	54・75
ADR-SUS		12	45	79
ADRL-SUS		20	50	83
ADR-SP	1.805	22	50	62
ADRS & ADRS-SV	1.81	10	38	44・65
ADR		22	50	48
ADR-SV		16	45	69
ADRL & ADRL-SV		32	60	54・75
ADR-SUS		12	45	79
ADRL-SUS		20	50	83
ADR-SUS		12	45	79

型番 CODE NUMBER	径 Diameter φ D	刃長 Flute Length ℓ	全長 O.A.L L	詳細ページ Page
ADRL-SUS	1.81	20	50	83
ADR-SP	1.815	22	50	62
ADRS & ADRS-SV	1.82	10	38	44・65
ADR		22	50	48
ADR-SV		16	45	69
ADRL & ADRL-SV		32	60	54・75
ADR-SUS		12	45	79
ADRL-SUS		20	50	83
ADR-SP		1.825	22	50
ADRS & ADRS-SV	1.83	10	38	44・65
ADR		22	50	48
ADR-SV		16	45	69
ADRL & ADRL-SV		32	60	54・75
ADR-SUS		12	45	79
ADRL-SUS		20	50	83
ADR-SP		1.835	22	50
ADRS & ADRS-SV	1.84	10	38	44・65
ADR		22	50	48
ADR-SV		16	45	69
ADRL & ADRL-SV		32	60	54・75
ADR-SUS		12	45	79
ADRL-SUS		20	50	83
ADR-SP		1.845	22	50
ADRS & ADRS-SV	1.85	10	38	44・65
ADR		22	50	48
ADR-SV		16	45	69
ADRSL & ADRSL-SV		27	60	51・72
ADRL & ADRL-SV		32	60	54・75
ADR-SUS		12	45	79
ADRL-SUS		20	50	83
ADR-SP	1.855	22	50	62
ADRS & ADRS-SV	1.86	10	38	44・65
ADR		22	50	48
ADR-SV		16	45	69
ADRL & ADRL-SV		32	60	54・75
ADR-SUS		12	45	79
ADRL-SUS		20	50	83
ADR-SP		1.865	22	50
ADRS & ADRS-SV	1.87	10	38	44・65
ADR		22	50	48
ADR-SV		16	45	69
ADRL & ADRL-SV		32	60	54・75
ADR-SUS		12	45	79
ADRL-SUS		20	50	83
ADRL-SUS		20	50	83

## ルーマ型 (3mmシャンク)早見表 φ1.875~φ2.17

単位 Unit : mm

型番 CODE NUMBER	径 Diameter φ D	刃長 Flute Length ℓ	全長 O.A.L L	詳細ページ Page
ADR-SP	1.875	22	50	62
ADRS & ADRS-SV	1.88	10	38	44・65
ADR		22	50	48
ADR-SV		16	45	69
ADRL & ADRL-SV		32	60	54・75
ADR-SUS		12	45	79
ADRL-SUS		20	50	83
ADR-SP		1.885	22	50
ADRS & ADRS-SV	1.89	10	38	44・65
ADR		22	50	48
ADR-SV		16	45	69
ADRL & ADRL-SV		32	60	54・75
ADR-SUS		12	45	79
ADRL-SUS		20	50	83
ADR-SP		1.895	22	50
ADRS & ADRS-SV	1.9	10	38	44・65
ADR		22	50	48
ADR-SV		16	45	69
ADRSL & ADRSL-SV		27	60	51・72
ADRL & ADRL-SV		32	60	54・75
ADR-SUS		12	45	79
ADRL-SUS		20	50	83
ADR-SP	1.905	22	50	62
ADRS & ADRS-SV	1.91	10	38	44・65
ADR		22	50	48
ADR-SV		16	45	69
ADRL & ADRL-SV		32	60	54・75
ADR-SUS		12	45	79
ADRL-SUS		20	50	83
ADR-SP		1.915	22	50
ADRS & ADRS-SV	1.92	10	38	44・65
ADR		22	50	48
ADR-SV		16	45	69
ADRL & ADRL-SV		32	60	54・75
ADR-SUS		12	45	79
ADRL-SUS		20	50	83
ADR-SP		1.925	22	50
ADRS & ADRS-SV	1.93	10	38	44・65
ADR		22	50	48
ADR-SV		16	45	69
ADRL & ADRL-SV		32	60	54・75
ADR-SUS		12	45	79
ADRL-SUS		20	50	83
ADR-SP		1.935	22	50

型番 CODE NUMBER	径 Diameter φ D	刃長 Flute Length ℓ	全長 O.A.L L	詳細ページ Page
ADRS & ADRS-SV	1.94	10	38	44・65
ADR		22	50	48
ADR-SV		16	45	69
ADRL & ADRL-SV		32	60	54・75
ADR-SUS		12	45	79
ADRL-SUS		20	50	83
ADR-SP		1.945	22	50
ADRS & ADRS-SV	1.95	10	38	44・65
ADR		22	50	48
ADR-SV		16	45	69
ADRSL & ADRSL-SV		27	60	51・72
ADRL & ADRL-SV		32	60	54・75
ADR-SUS		12	45	79
ADRL-SUS		20	50	83
ADR-SP	1.955	22	50	62
ADRS & ADRS-SV	1.96	10	38	44・65
ADR		22	50	48
ADR-SV		16	45	69
ADRL & ADRL-SV		32	60	54・75
ADR-SUS		12	45	79
ADRL-SUS		20	50	83
ADR-SP		1.965	22	50
ADRS & ADRS-SV	1.97	10	38	44・65
ADR		22	50	48
ADR-SV		16	45	69
ADRL & ADRL-SV		32	60	54・75
ADR-SUS		12	45	79
ADRL-SUS		20	50	83
ADR-SP		1.975	22	50
ADRS & ADRS-SV	1.98	10	38	44・65
ADR		22	50	48
ADR-SV		16	45	69
ADRL & ADRL-SV		32	60	54・75
ADR-SUS		12	45	79
ADRL-SUS		20	50	83
ADR-SP		1.985	22	50
ADRS & ADRS-SV	1.99	10	38	44・65
ADR		22	50	48
ADR-SV		16	45	69
ADRL & ADRL-SV		32	60	54・75
ADR-SUS		12	45	79
ADRL-SUS		20	50	83
ADR-SP		1.995	22	50
ADRS & ADRS-SV	2	10	38	44・65



単位 Unit : mm

型番 CODE NUMBER	径 Diameter φ D	刃長 Flute Length ℓ	全長 O.A.L L	詳細ページ Page
ADR & ADR-SV	2	22	50	48・69
ADRSL & ADRSL-SV		27	60	51・72
ADRL & ADRL-SV		32		54・75
ADR-SUS		12	45	79
ADRL-SUS		20	50	83
ADRS & ADRS-SV	2.01	10	38	44・65
ADR & ADR-SV		22	50	48・69
ADRL & ADRL-SV		32	60	54・75
ADR-SUS		12	45	79
ADRL-SUS		20	50	83
ADRS & ADRS-SV	2.02	10	38	44・65
ADR & ADR-SV		22	50	48・69
ADRL & ADRL-SV		32	60	54・75
ADR-SUS		12	45	79
ADRL-SUS		20	50	83
ADRS & ADRS-SV	2.03	10	38	44・65
ADR & ADR-SV		22	50	48・69
ADRL & ADRL-SV		32	60	54・75
ADR-SUS		12	45	79
ADRL-SUS		20	50	83
ADRS & ADRS-SV	2.04	10	38	44・65
ADR & ADR-SV		22	50	48・69
ADRL & ADRL-SV		32	60	54・75
ADR-SUS		12	45	79
ADRL-SUS		20	50	83
ADRS & ADRS-SV	2.05	10	38	44・65
ADR & ADR-SV		22	50	48・69
ADRL & ADRL-SV		32	60	54・75
ADR-SUS		12	45	79
ADRL-SUS		20	50	83
ADRS & ADRS-SV	2.06	10	38	44・65
ADR & ADR-SV		22	50	48・69
ADRL & ADRL-SV		32	60	54・75
ADR-SUS		12	45	79
ADRL-SUS		20	50	83
ADRS & ADRS-SV	2.07	10	38	44・65
ADR & ADR-SV		22	50	48・69
ADRL & ADRL-SV		32	60	54・75
ADR-SUS		12	45	79
ADRL-SUS		20	50	83
ADRS & ADRS-SV	2.08	10	38	44・65
ADR & ADR-SV		22	50	48・69
ADRL & ADRL-SV		32	60	54・75
ADR-SUS		12	45	79

型番 CODE NUMBER	径 Diameter φ D	刃長 Flute Length ℓ	全長 O.A.L L	詳細ページ Page
ADRL-SUS	2.08	20	50	83
ADRS & ADRS-SV	2.09	10	38	44・65
ADR & ADR-SV		22	50	48・69
ADRL & ADRL-SV		32	60	54・75
ADR-SUS		12	45	79
ADRL-SUS		20	50	83
ADRS & ADRS-SV	2.1	10	38	44・65
ADR & ADR-SV		22	50	48・69
ADRL & ADRL-SV		32	60	54・75
ADR-SUS		12	45	79
ADRL-SUS		20	50	83
ADRS & ADRS-SV	2.11	10	38	44・65
ADR & ADR-SV		22	50	48・69
ADRL & ADRL-SV		32	60	54・75
ADR-SUS		12	45	79
ADRL-SUS		20	50	83
ADRS & ADRS-SV	2.12	10	38	44・65
ADR & ADR-SV		22	50	48・69
ADRL & ADRL-SV		32	60	54・75
ADR-SUS		12	45	79
ADRL-SUS		20	50	83
ADRS & ADRS-SV	2.13	10	38	44・65
ADR & ADR-SV		22	50	48・69
ADRL & ADRL-SV		32	60	54・75
ADR-SUS		12	45	79
ADRL-SUS		20	50	83
ADRS & ADRS-SV	2.14	10	38	44・65
ADR & ADR-SV		22	50	48・69
ADRL & ADRL-SV		32	60	54・75
ADR-SUS		12	45	79
ADRL-SUS		20	50	83
ADRS & ADRS-SV	2.15	10	38	44・65
ADR & ADR-SV		22	50	48・69
ADRL & ADRL-SV		32	60	54・75
ADR-SUS		12	45	79
ADRL-SUS		20	50	83
ADRS & ADRS-SV	2.16	10	38	44・65
ADR & ADR-SV		22	50	48・69
ADRL & ADRL-SV		32	60	54・75
ADR-SUS		12	45	79
ADRL-SUS		20	50	83
ADRS & ADRS-SV	2.17	10	38	44・65
ADR & ADR-SV		22	50	48・69
ADRL & ADRL-SV		32	60	54・75

ルーマ型 (3mmシャンク)早見表 φ2.17~φ2.52

単位 Unit : mm

型番 CODE NUMBER	径 Diameter φ D	刃長 Flute Length ℓ	全長 O.A.L L	詳細ページ Page
ADR-SUS	2.17	12	45	79
ADRL-SUS		20	50	83
ADRS & ADRS-SV	2.18	10	38	44・65
ADR & ADR-SV		22	50	48・69
ADRL & ADRL-SV		32	60	54・75
ADR-SUS		12	45	79
ADRL-SUS	2.19	20	50	83
ADRS & ADRS-SV		10	38	44・65
ADR & ADR-SV		22	50	48・69
ADRL & ADRL-SV		32	60	54・75
ADR-SUS	2.2	12	45	79
ADRL-SUS		20	50	83
ADRS & ADRS-SV		10	38	44・65
ADR & ADR-SV		22	50	48・69
ADRL & ADRL-SV	2.21	32	60	54・75
ADR-SUS		12	45	79
ADRL-SUS		22	50	83
ADRS & ADRS-SV		10	38	44・65
ADR & ADR-SV	2.22	22	50	48・69
ADRL & ADRL-SV		32	60	54・75
ADR-SUS		12	45	79
ADRL-SUS		22	50	83
ADRS & ADRS-SV	2.23	10	38	44・65
ADR & ADR-SV		22	50	48・70
ADRL & ADRL-SV		32	60	54・76
ADR-SUS		12	45	79
ADRL-SUS	2.24	22	50	83
ADRS & ADRS-SV		10	38	44・65
ADR & ADR-SV		22	50	48・70
ADRL & ADRL-SV		32	60	54・76
ADR-SUS	2.25	12	45	79
ADRL-SUS		22	50	83
ADRS & ADRS-SV		10	38	44・65
ADR & ADR-SV		22	50	48・70
ADRL & ADRL-SV	2.26	32	60	54・76
ADR-SUS		12	45	79
ADRL-SUS	2.26	22	50	83
ADRS & ADRS-SV		10	38	44・65
ADR & ADR-SV	22	50	48・70	

型番 CODE NUMBER	径 Diameter φ D	刃長 Flute Length ℓ	全長 O.A.L L	詳細ページ Page
ADRL & ADRL-SV	2.26	32	60	54・76
ADR-SUS		12	45	79
ADRL-SUS		22	50	83
ADRS & ADRS-SV	2.27	10	38	44・65
ADR & ADR-SV		22	50	48・70
ADRL & ADRL-SV		32	60	54・76
ADR-SUS		12	45	79
ADRL-SUS	2.28	22	50	83
ADRS & ADRS-SV		10	38	44・65
ADR & ADR-SV		22	50	48・70
ADRL & ADRL-SV		32	60	54・76
ADR-SUS	2.29	12	45	79
ADRL-SUS		22	50	83
ADRS & ADRS-SV		10	38	44・65
ADR & ADR-SV		22	50	48・70
ADRL & ADRL-SV	2.3	32	60	54・76
ADR-SUS		12	45	79
ADRL-SUS		22	50	83
ADRS & ADRS-SV		10	38	44・66
ADR & ADR-SV	2.31	22	50	49・70
ADRL & ADRL-SV		32	60	55・76
ADR-SUS		12	45	79
ADRL-SUS		22	50	83
ADRS & ADRS-SV	2.32	10	38	44・66
ADR & ADR-SV		22	50	49・70
ADRL & ADRL-SV		32	60	55・76
ADR-SUS		12	45	79
ADRL-SUS	2.33	22	50	83
ADRS & ADRS-SV		10	38	44・66
ADR & ADR-SV		22	50	49・70
ADRL & ADRL-SV		32	60	55・76
ADR-SUS	2.34	12	45	79
ADRL-SUS		22	50	83
ADRS & ADRS-SV		10	38	44・66
ADR & ADR-SV		22	50	49・70
ADRL & ADRL-SV	2.35	32	60	55・76
ADR-SUS		12	45	79
ADRL-SUS	2.35	22	50	83
ADRS & ADRS-SV		10	38	44・66

ドリル早見表 (3mmシャンク)  
Simplified Drill Size Table

単位 Unit : mm

型番 CODE NUMBER	径 Diameter φ D	刃長 Flute Length ℓ	全長 O.A.L L	詳細ページ Page
ADR & ADR-SV	2.35	22	50	49・70
ADRL & ADRL-SV		32	60	55・76
ADR-SUS		12	45	79
ADRL-SUS		22	50	83
ADRS & ADRS-SV	2.36	10	38	44・66
ADR & ADR-SV		22	50	49・70
ADRL & ADRL-SV		32	60	55・76
ADR-SUS		12	45	79
ADRL-SUS	22	50	83	
ADRS & ADRS-SV	2.37	10	38	44・66
ADR & ADR-SV		22	50	49・70
ADRL & ADRL-SV		32	60	55・76
ADR-SUS		12	45	79
ADRL-SUS	22	50	83	
ADRS & ADRS-SV	2.38	10	38	45・66
ADR & ADR-SV		22	50	49・70
ADRL & ADRL-SV		32	60	55・76
ADR-SUS		12	45	80
ADRL-SUS	22	50	84	
ADRS & ADRS-SV	2.39	10	38	45・66
ADR & ADR-SV		22	50	49・70
ADRL & ADRL-SV		32	60	55・76
ADR-SUS		12	45	80
ADRL-SUS	22	50	84	
ADRS & ADRS-SV	2.4	10	38	45・66
ADR & ADR-SV		22	50	49・70
ADRL & ADRL-SV		32	60	55・76
ADR-SUS		12	45	80
ADRL-SUS	22	50	84	
ADRS & ADRS-SV	2.41	10	38	45・66
ADR & ADR-SV		22	50	49・70
ADRL & ADRL-SV		32	60	55・76
ADR-SUS		12	45	80
ADRL-SUS	22	50	84	
ADRS & ADRS-SV	2.42	10	38	45・66
ADR & ADR-SV		22	50	49・70
ADRL & ADRL-SV		32	60	55・76
ADR-SUS		12	45	80
ADRL-SUS	22	50	84	
ADRS & ADRS-SV	2.43	10	38	45・66
ADR & ADR-SV		22	50	49・70
ADRL & ADRL-SV		32	60	55・76
ADR-SUS		12	45	80
ADRL-SUS	22	50	84	

型番 CODE NUMBER	径 Diameter φ D	刃長 Flute Length ℓ	全長 O.A.L L	詳細ページ Page
ADRS & ADRS-SV	2.44	10	38	45・66
ADR & ADR-SV		22	50	49・70
ADRL & ADRL-SV		32	60	55・76
ADR-SUS		12	45	80
ADRL-SUS	22	50	84	
ADRS & ADRS-SV	2.45	10	38	45・66
ADR & ADR-SV		22	50	49・70
ADRL & ADRL-SV		32	60	55・76
ADR-SUS		12	45	80
ADRL-SUS	22	50	84	
ADRS & ADRS-SV	2.46	10	38	45・66
ADR & ADR-SV		22	50	49・70
ADRL & ADRL-SV		32	60	55・76
ADR-SUS		12	45	80
ADRL-SUS	22	50	84	
ADRS & ADRS-SV	2.47	10	38	45・66
ADR & ADR-SV		22	50	49・70
ADRL & ADRL-SV		32	60	55・76
ADR-SUS		12	45	80
ADRL-SUS	22	50	84	
ADRS & ADRS-SV	2.48	10	38	45・66
ADR & ADR-SV		22	50	49・70
ADRL & ADRL-SV		32	60	55・76
ADR-SUS		12	45	80
ADRL-SUS	22	50	84	
ADRS & ADRS-SV	2.49	10	38	45・66
ADR & ADR-SV		22	50	49・70
ADRL & ADRL-SV		32	60	55・76
ADR-SUS		12	45	80
ADRL-SUS	22	50	84	
ADRS & ADRS-SV	2.5	10	38	45・66
ADR & ADR-SV		22	50	49・70
ADRSL & ADRSL-SV		27	60	51・72
ADRL & ADRL-SV		32	60	55・76
ADR-SUS	12	45	80	
ADRL-SUS	22	50	84	
ADRS & ADRS-SV	2.51	10	38	45・66
ADR & ADR-SV		22	50	49・70
ADRL & ADRL-SV		32	60	55・76
ADR-SUS		12	45	80
ADRL-SUS	22	50	84	
ADRS & ADRS-SV	2.52	10	38	45・66
ADR & ADR-SV		22	50	49・70
ADRL & ADRL-SV	32	60	55・76	

## ルーマ型 (3mmシャンク)早見表 φ2.52 ~ φ2.87

単位 Unit : mm

型番 CODE NUMBER	径 Diameter φ D	刃長 Flute Length ℓ	全長 O.A.L L	詳細ページ Page
ADR-SUS	2.52	12	45	80
ADRL-SUS		22	50	84
ADRS & ADRS-SV	2.53	10	38	45・66
ADR & ADR-SV		22	50	49・70
ADRL & ADRL-SV		32	60	55・76
ADR-SUS		12	45	80
ADRL-SUS	2.54	22	50	84
ADRS & ADRS-SV		10	38	45・66
ADR & ADR-SV		22	50	49・70
ADRL & ADRL-SV		32	60	55・76
ADR-SUS	2.55	12	45	80
ADRL-SUS		22	50	84
ADRS & ADRS-SV		10	38	45・66
ADR & ADR-SV		22	50	49・70
ADRL & ADRL-SV	2.56	32	60	55・76
ADR-SUS		12	45	80
ADRL-SUS		22	50	84
ADRS & ADRS-SV		10	38	45・66
ADR & ADR-SV	2.57	22	50	49・70
ADRL & ADRL-SV		32	60	55・76
ADR-SUS		12	45	80
ADRL-SUS		22	50	84
ADRS & ADRS-SV	2.58	10	38	45・66
ADR & ADR-SV		22	50	49・70
ADRL & ADRL-SV		32	60	55・76
ADR-SUS		12	45	80
ADRL-SUS	2.59	22	50	84
ADRS & ADRS-SV		10	38	45・66
ADR & ADR-SV		22	50	49・70
ADRL & ADRL-SV		32	60	55・76
ADR-SUS	2.6	12	45	80
ADRL-SUS		22	50	84
ADRS & ADRS-SV		10	38	45・66
ADR & ADR-SV		22	50	49・70
ADRL & ADRL-SV	2.61	32	60	55・76
ADR-SUS		12	45	80
ADRL-SUS		22	50	84
ADRS & ADRS-SV		10	38	45・66
ADR & ADR-SV	2.62	22	50	49・70
ADRL & ADRL-SV		32	60	55・76
ADR-SUS		12	45	80
ADRL-SUS		22	50	84
ADRS & ADRS-SV	2.63	10	38	45・66
ADR & ADR-SV		22	50	49・70
ADRL & ADRL-SV		32	60	55・76
ADR-SUS		12	45	80
ADRL-SUS	2.64	22	50	84
ADRS & ADRS-SV		10	38	45・66
ADR & ADR-SV		22	50	49・70
ADRL & ADRL-SV		32	60	55・76
ADR-SUS	2.65	12	45	80
ADRL-SUS		22	50	84
ADRS & ADRS-SV		10	38	45・66
ADR & ADR-SV		22	50	49・70
ADRL & ADRL-SV	2.66	32	60	55・76
ADR-SUS		12	45	80
ADRL-SUS		22	50	84
ADRS & ADRS-SV		10	38	45・66
ADR & ADR-SV	2.67	22	50	49・70
ADRL & ADRL-SV		32	60	55・76
ADR-SUS		12	45	80
ADRL-SUS		22	50	84
ADRS & ADRS-SV	2.68	10	38	45・66
ADR & ADR-SV		22	50	49・70
ADRL & ADRL-SV		32	60	55・76
ADR-SUS		12	45	80
ADRL-SUS	2.69	22	50	84
ADRS & ADRS-SV		10	38	45・66
ADR & ADR-SV		22	50	49・70
ADRL & ADRL-SV		32	60	55・76
ADR-SUS	2.7	12	45	80
ADRL-SUS		22	50	84
ADRS & ADRS-SV		10	38	45・66
ADR & ADR-SV		22	50	49・70

型番 CODE NUMBER	径 Diameter φ D	刃長 Flute Length ℓ	全長 O.A.L L	詳細ページ Page
ADRL & ADRL-SV	2.61	32	60	55・76
ADR-SUS		12	45	80
ADRL-SUS		22	50	84
ADRS & ADRS-SV	2.62	10	38	45・66
ADR & ADR-SV		22	50	49・70
ADRL & ADRL-SV		32	60	55・76
ADR-SUS		12	45	80
ADRL-SUS	2.63	22	50	84
ADRS & ADRS-SV		10	38	45・66
ADR & ADR-SV		22	50	49・70
ADRL & ADRL-SV		32	60	55・76
ADR-SUS	2.64	12	45	80
ADRL-SUS		22	50	84
ADRS & ADRS-SV		10	38	45・66
ADR & ADR-SV		22	50	49・70
ADRL & ADRL-SV	2.65	32	60	55・76
ADR-SUS		12	45	80
ADRL-SUS		22	50	84
ADRS & ADRS-SV		10	38	45・66
ADR & ADR-SV	2.66	22	50	49・70
ADRL & ADRL-SV		32	60	55・76
ADR-SUS		12	45	80
ADRL-SUS		22	50	84
ADRS & ADRS-SV	2.67	10	38	45・66
ADR & ADR-SV		22	50	49・70
ADRL & ADRL-SV		32	60	55・76
ADR-SUS		12	45	80
ADRL-SUS	2.68	22	50	84
ADRS & ADRS-SV		10	38	45・66
ADR & ADR-SV		22	50	49・70
ADRL & ADRL-SV		32	60	55・76
ADR-SUS	2.69	12	45	80
ADRL-SUS		22	50	84
ADRS & ADRS-SV		10	38	45・66
ADR & ADR-SV		22	50	49・70
ADRL & ADRL-SV	2.7	32	60	55・76
ADR-SUS		12	45	80
ADRL-SUS		22	50	84
ADRS & ADRS-SV		10	38	45・66

単位 Unit : mm

型番 CODE NUMBER	径 Diameter φ D	刃長 Flute Length ℓ	全長 O.A.L L	詳細ページ Page
ADR & ADR-SV	2.7	25	50	49・70
ADRL & ADRL-SV		40	65	55・76
ADR-SUS		15	45	80
ADRL-SUS		25	60	84
ADRS & ADRS-SV	2.71	12	38	45・66
ADR & ADR-SV		25	50	49・70
ADRL & ADRL-SV		40	65	55・76
ADR-SUS		15	45	80
ADRL-SUS	2.72	25	60	84
ADRS & ADRS-SV		12	38	45・66
ADR & ADR-SV		25	50	49・70
ADRL & ADRL-SV		40	65	55・76
ADR-SUS	2.73	15	45	80
ADRL-SUS		25	60	84
ADRS & ADRS-SV		12	38	45・66
ADR & ADR-SV		25	50	49・70
ADRL & ADRL-SV	2.74	40	65	55・76
ADR-SUS		15	45	80
ADRL-SUS		25	60	84
ADRS & ADRS-SV		12	38	45・66
ADR & ADR-SV	2.75	25	50	49・70
ADRL & ADRL-SV		40	65	55・76
ADR-SUS		15	45	80
ADRL-SUS		25	60	84
ADRS & ADRS-SV	2.76	12	38	45・66
ADR & ADR-SV		25	50	49・70
ADRL & ADRL-SV		40	65	55・76
ADR-SUS		15	45	80
ADRL-SUS	2.77	25	60	84
ADRS & ADRS-SV		12	38	45・66
ADR & ADR-SV		25	50	49・70
ADRL & ADRL-SV		40	65	55・76
ADR-SUS	2.78	15	45	80
ADRL-SUS		25	60	84
ADRS & ADRS-SV		12	38	45・66
ADR & ADR-SV		25	50	49・70
ADRL & ADRL-SV	2.78	40	65	55・76
ADR-SUS		15	45	80
ADRL-SUS		25	60	84

型番 CODE NUMBER	径 Diameter φ D	刃長 Flute Length ℓ	全長 O.A.L L	詳細ページ Page
ADRS & ADRS-SV	2.79	12	38	45・66
ADR & ADR-SV		25	50	49・70
ADRL & ADRL-SV		40	65	55・76
ADR-SUS		15	45	80
ADRL-SUS	2.8	25	60	84
ADRS & ADRS-SV		12	38	45・66
ADR & ADR-SV		25	50	49・70
ADRL & ADRL-SV		40	65	55・76
ADR-SUS	2.81	15	45	80
ADRL-SUS		25	60	84
ADRS & ADRS-SV		12	38	45・66
ADR & ADR-SV		25	50	49・70
ADRL & ADRL-SV	2.82	40	65	55・76
ADR-SUS		15	45	80
ADRL-SUS		25	60	84
ADRS & ADRS-SV		12	38	45・66
ADR & ADR-SV	2.83	25	50	49・70
ADRL & ADRL-SV		40	65	55・76
ADR-SUS		15	45	80
ADRL-SUS		25	60	84
ADRS & ADRS-SV	2.84	12	38	45・66
ADR & ADR-SV		25	50	49・70
ADRL & ADRL-SV		40	65	55・76
ADR-SUS		15	45	80
ADRL-SUS	2.85	25	60	84
ADRS & ADRS-SV		12	38	45・66
ADR & ADR-SV		25	50	49・70
ADRL & ADRL-SV		40	65	55・76
ADR-SUS	2.86	15	45	80
ADRL-SUS		25	60	84
ADRS & ADRS-SV		12	38	45・66
ADR & ADR-SV		25	50	49・70
ADRL & ADRL-SV	2.87	40	65	55・76
ADR-SUS		15	45	80
ADRL-SUS		25	60	84

ルーマ型 (3mmシャンク)早見表 φ2.87~φ3.0

単位 Unit : mm

ドリル早見表【3mmシャンク】  
Simplified Drill Size Table

型番 CODE NUMBER	径 Diameter φ D	刃長 Flute Length ℓ	全長 O.A.L L	詳細ページ Page
ADRL-SUS	2.87	25	60	84
ADRS & ADRS-SV	2.88	12	38	45・66
ADR & ADR-SV		25	50	49・70
ADRL & ADRL-SV		40	65	55・76
ADR-SUS		15	45	80
ADRL-SUS		25	60	84
ADRS & ADRS-SV	2.89	12	38	45・66
ADR & ADR-SV		25	50	49・70
ADRL & ADRL-SV		40	65	55・76
ADR-SUS		15	45	80
ADRL-SUS		25	60	84
ADRS & ADRS-SV	2.9	12	38	45・66
ADR & ADR-SV		25	50	49・70
ADRL & ADRL-SV		40	65	55・76
ADR-SUS		15	45	80
ADRL-SUS		25	60	84
ADRS & ADRS-SV	2.91	12	38	45・66
ADR & ADR-SV		25	50	49・70
ADRL & ADRL-SV		40	65	55・76
ADR-SUS		15	45	80
ADRL-SUS		25	60	84
ADRS & ADRS-SV	2.92	12	38	45・66
ADR & ADR-SV		25	50	49・70
ADRL & ADRL-SV		40	65	55・76
ADR-SUS		15	45	80
ADRL-SUS		25	60	84
ADRS & ADRS-SV	2.93	12	38	45・66
ADR & ADR-SV		25	50	49・70
ADRL & ADRL-SV		40	65	55・76
ADR-SUS		15	45	80
ADRL-SUS		25	60	84
ADRS & ADRS-SV	2.94	12	38	45・66
ADR & ADR-SV		25	50	49・70
ADRL & ADRL-SV		40	65	55・76
ADR-SUS		15	45	80
ADRL-SUS		25	60	84
ADRS & ADRS-SV	2.95	12	38	45・66
ADR & ADR-SV		25	50	49・70
ADRL & ADRL-SV		40	65	55・76
ADR-SUS		15	45	80
ADRL-SUS		25	60	84
ADRS & ADRS-SV	2.96	12	38	45・66
ADR & ADR-SV		25	50	49・70
ADRL & ADRL-SV		40	65	55・76

型番 CODE NUMBER	径 Diameter φ D	刃長 Flute Length ℓ	全長 O.A.L L	詳細ページ Page
ADR-SUS	2.96	15	45	80
ADRL-SUS		25	60	84
ADRS & ADRS-SV	2.97	12	38	45・66
ADR & ADR-SV		25	50	49・70
ADRL & ADRL-SV		40	65	55・76
ADR-SUS		15	45	80
ADRL-SUS		25	60	84
ADRS & ADRS-SV	2.98	12	38	45・66
ADR & ADR-SV		25	50	49・70
ADRL & ADRL-SV		40	65	55・76
ADR-SUS		15	45	80
ADRL-SUS		25	60	84
ADRS & ADRS-SV	2.99	12	38	45・66
ADR & ADR-SV		25	50	49・70
ADRL & ADRL-SV		40	65	55・76
ADR-SUS		15	45	80
ADRL-SUS		25	60	84
ADRS & ADRS-SV	3	12	38	45・66
ADR & ADR-SV		25	50	49・70
ADRSL & ADRSL-SV		33	60	51・72
ADRL & ADRL-SV		40	65	55・76
ADR-SUS		15	45	80
ADRL-SUS	25	60	84	

# ストレートシャンクドリル早見表 φ0.3～φ1.15

単位 Unit : mm

型番 CODE NUMBER	径 Diameter φ D	刃長 Flute Length ℓ	全長 O.A.L L	詳細ページ Page
ADS & V-ADS	0.3	4	30	88-106
ADSL		8	40	97
ADL		10	60	100
ADLL		15	75	103
ADS & V-ADS	0.31 ~ 0.34	4	30	88-106
ADS & V-ADS	0.35	4	30	88-106
ADSL		8	40	97
ADL		10	60	100
ADLL		15	75	103
ADS & V-ADS	0.36 ~ 0.39	4	30	88-106
ADS & V-ADS	0.4	5	30	88-106
ADSL		8	40	97
ADL		10	60	100
ADLL		15	75	103
ADS & V-ADS	0.41 ~ 0.44	5	30	88-106
ADS & V-ADS	0.45	5	30	88-106
ADSL		8	40	97
ADL		10	60	100
ADLL		15	75	103
ADS & V-ADS	0.46 ~ 0.49	5	30	88-106
ADS & V-ADS	0.5	6	30	88-106
ADSL		8	40	97
ADL		10	60	100
ADLL		15	75	103
ADS & V-ADS	0.51 ~ 0.54	6	30	88-106
ADS & V-ADS	0.55	6	30	88-106
ADSL		8	40	97
ADL		15	65	100
ADLL		20	90	103
ADS & V-ADS	0.56 ~ 0.59	6	30	88-106
ADS & V-ADS	0.6	6	30	88-106
ADSL		8	40	97
ADL		15	65	100
ADLL		20	90	103
ADS & V-ADS	0.61 ~ 0.64	6	30	88-106
ADS & V-ADS	0.65	6	30	88-106
ADSL		8	40	97
ADL		15	65	100
ADLL		20	90	103
ADS & V-ADS	0.66 ~ 0.69	6	30	88-106
ADS & V-ADS	0.7	12	40	88-106
ADSL		15	50	97
ADL		15	65	100
ADLL		20	90	103

型番 CODE NUMBER	径 Diameter φ D	刃長 Flute Length ℓ	全長 O.A.L L	詳細ページ Page
ADS & V-ADS	0.71 ~ 0.74	12	40	88-106
ADS & V-ADS	0.75	12	40	88-106
ADSL		15	50	97
ADL		15	65	100
ADLL		20	90	103
ADS & V-ADS	0.76 ~ 0.79	12	40	88-106
ADS & V-ADS	0.8	12	40	88-106
ADSL		15	50	97
ADL		20	75	100
ADLL		25	100	103
ADS & V-ADS	0.81 ~ 0.84	12	40	88-106
ADS & V-ADS	0.85	12	40	89-107
ADSL		15	50	97
ADL		20	75	100
ADLL		25	100	103
ADS & V-ADS	0.86 ~ 0.89	12	40	89-107
ADS & V-ADS	0.9	12	40	89-107
ADSL		15	50	97
ADL		20	75	100
ADLL		25	100	103
ADS & V-ADS	0.91 ~ 0.94	12	40	89-107
ADS & V-ADS	0.95	12	40	89-107
ADSL		15	50	97
ADL		20	75	100
ADLL		25	100	103
ADS & V-ADS	0.96 ~ 0.99	12	40	89-107
ADS & V-ADS	1	15	40	89-107
ADSL		16	50	97
ADL		25	75	100
ADLL		30	100	103
ACD		15	40	111
ADS & V-ADS	1.01 ~ 1.04	15	40	89-107
ADS & V-ADS	1.05	15	40	89-107
ADSL		16	50	97
ADL		25	75	100
ADLL		30	100	103
ADS & V-ADS	1.06 ~ 1.09	15	40	89-107
ADS & V-ADS	1.1	15	40	89-107
ADSL		16	50	97
ADL		25	75	100
ADLL		30	100	103
ACD		15	40	111
ADS & V-ADS	1.11 ~ 1.14	15	40	89-107
ADS & V-ADS	1.15	15	40	89-107

ストレートシャンクドリル早見表 φ1.15～φ2.75

単位 Unit : mm

型番 CODE NUMBER	径 Diameter φ D	刃長 Flute Length ℓ	全長 O.A.L L	詳細ページ Page
ADSL	1.15	16	50	97
ADL		25	75	100
ADLL		30	100	103
ADS & V-ADS	1.16 ~ 1.19	15	40	89・107
ADS & V-ADS	1.2	15	40	89・107
ADSL		18	50	97
ADL		25	75	100
ADLL		35	100	103
ACD		15	40	111
ADS & V-ADS	1.21 ~ 1.24	15	40	89・107
ADS & V-ADS	1.25	15	40	89・107
ADSL		18	50	97
ADL		25	75	100
ADLL		35	100	103
ADS & V-ADS	1.26 ~ 1.29	15	40	89・107
ADS & V-ADS	1.3	16	40	89・107
ADSL		18	50	97
ADL		25	75	100
ADLL		35	100	103
ACD		16	40	111
ADS & V-ADS	1.31 ~ 1.34	16	40	89・107
ADS & V-ADS	1.35	16	40	89・107
ADSL		18	50	97
ADL		25	75	100
ADLL		35	100	103
ADS & V-ADS	1.36 ~ 1.39	16	40	89・107
ADS & V-ADS	1.4	16	40	89・107
ADSL		18	50	97
ADL		30	75	100
ADLL		40	100	103
ACD		16	40	111
ADS & V-ADS		1.41 ~ 1.44	16	40
ADS & V-ADS	1.45	16	40	89・107
ADSL		18	50	97
ADL		30	75	100
ADLL		40	100	103
ADS & V-ADS	1.46 ~ 1.49	16	40	89・107
ADS & V-ADS	1.5	16	40	89・107
ADSL		24	50	97
ADL		30	75	100
ADLL		40	100	103
ACD		16	40	111
ADS & V-ADS		1.51 ~ 1.54	16	40
ADS & V-ADS	1.55	16	40	89・107

型番 CODE NUMBER	径 Diameter φ D	刃長 Flute Length ℓ	全長 O.A.L L	詳細ページ Page
ADSL	1.55	24	50	97
ADL		30	75	100
ADLL		40	100	103
ADS & V-ADS	1.56 ~ 1.59	16	40	89・107
ADS & V-ADS	1.6	18	40	89・107
ADSL		24	55	97
ADL		30	75	100
ADLL		40	100	103
ACD		18	40	111
ADS & V-ADS	1.61 ~ 1.64	18	40	89・107
ADS & V-ADS	1.65	18	40	89・107
ADSL		24	55	97
ADL		30	75	100
ADLL		40	100	103
ADS & V-ADS	1.66 ~ 1.69	18	40	89・107
ADS & V-ADS	1.7	18	40	90・108
ADSL		24	55	97
ADL		30	75	100
ADLL		40	100	103
ACD		18	40	111
ADS & V-ADS	1.71 ~ 1.74	18	40	90・108
ADS & V-ADS	1.75	18	40	90・108
ADSL		24	55	97
ADL		30	75	100
ADLL		40	100	103
ADS & V-ADS	1.76 ~ 1.79	18	40	90・108
ADS & V-ADS	1.8	18	40	90・108
ADSL		24	55	97
ADL		30	75	100
ADLL		40	100	103
ACD		18	40	111
ADS & V-ADS		1.81 ~ 1.84	18	40
ADS & V-ADS	1.85	18	40	90・108
ADSL		24	55	97
ADL		30	75	100
ADLL		40	100	103
ADS & V-ADS	1.86 ~ 1.89	18	40	90・108
ADS & V-ADS	1.9	18	40	90・108
ADSL		24	55	97
ADL		30	75	100
ADLL		40	100	103
ACD		18	40	111
ADS & V-ADS		1.91 ~ 1.94	18	40
ADS & V-ADS	1.95	18	40	90・108

ドリル早見表「ストレートシャンク」  
Simplified Drill Size Table



単位 Unit : mm

型番 CODE NUMBER	径 Diameter φ D	刃長 Flute Length ℓ	全長 O.A.L L	詳細ページ Page
ADSL	1.95	24	55	97
ADL		30	75	100
ADLL		40	100	103
ADS & V-ADS	1.96 ~ 1.99	18	40	90・108
ADS & V-ADS	2	18	40	90・108
ADSL		24	55	97
ADL		30	75	100
ADLL		40	100	103
ACD		18	40	111
ADS & V-ADS	2.01 ~ 2.04	18	40	90・108
ADS & V-ADS	2.05	18	40	90・108
ADSL		24	55	97
ADL		30	75	100
ADLL		40	100	103
ADS & V-ADS	2.06 ~ 2.09	18	40	90・108
ADS & V-ADS	2.1	20	40(45)	90・108
ADSL		24	55	97
ADL		30	75	100
ADLL		40	100	103
ACD		20	40(45)	111
ADS & V-ADS		2.11 ~ 2.14	20	40(45)
ADS & V-ADS	2.15	20	40(45)	90・108
ADSL		24	55	97
ADL		30	75	100
ADLL		40	100	103
ADS & V-ADS	2.16 ~ 2.19	20	40(45)	90・108
ADS & V-ADS	2.2	20	40(45)	90・108
ADSL		26	58(65)	97
ADL		30	75	100
ADLL		40	100	103
ACD		20	40(45)	111
ADS & V-ADS		2.21 ~ 2.24	20	40(45)
ADS & V-ADS	2.25	20	40(45)	90・108
ADSL		26	58(65)	97
ADL		30	75	100
ADLL		40	100	103
ADS & V-ADS	2.26 ~ 2.29	20	40(45)	90・108
ADS & V-ADS	2.3	20	40(45)	90・108
ADSL		26	58(65)	97
ADL		30	75	100
ADLL		40	100	103
ACD		20	40(45)	111
ADS & V-ADS	2.31 ~ 2.34	20	40(45)	90・108
ADS & V-ADS	2.35	20	40(45)	90・108

型番 CODE NUMBER	径 Diameter φ D	刃長 Flute Length ℓ	全長 O.A.L L	詳細ページ Page
ADSL	2.35	26	58(65)	97
ADL		30	75	100
ADLL		40	100	103
ADS & V-ADS	2.36 ~ 2.39	20	40(45)	90・108
ADS & V-ADS	2.4	20	40(45)	90・108
ADSL		26	61(65)	97
ADL		35	100	100
ADLL		50	150	103
ACD		20	40(45)	111
ADS & V-ADS	2.41 ~ 2.44	20	40(45)	90・108
ADS & V-ADS	2.45	20	40(45)	90・108
ADSL		26	61(65)	97
ADL		35	100	100
ADLL		50	150	103
ADS & V-ADS	2.46 ~ 2.49	20	40(45)	90・108
ADS & V-ADS	2.5	20	40(45)	90・108
ADSL		26	61(65)	97
ADL		35	100	100
ADLL		50	150	103
ACD		20	40(45)	111
ADS & V-ADS		2.51 ~ 2.54	20	40(45)
ADS & V-ADS	2.55	20	40(45)	90・108
ADSL		26	61(65)	97
ADL		35	100	100
ADLL		50	150	103
ADS & V-ADS	2.56 ~ 2.59	20	40(45)	90・108
ADS & V-ADS	2.6	20	45	91・109
ADSL		28	64(65)	97
ADL		35	100	100
ADLL		50	150	103
ACD		20	45	111
ADS & V-ADS	2.61 ~ 2.64	20	45	91・109
ADS & V-ADS	2.65	20	45	91・109
ADSL		28	64(65)	97
ADL		35	100	100
ADLL		50	150	103
ADS & V-ADS	2.66 ~ 2.69	20	45	91・109
ADS & V-ADS	2.7	20	45	91・109
ADSL		28	64(65)	97
ADL		35	100	100
ADLL		50	150	103
ACD		20	45	111
ADS & V-ADS	2.71 ~ 2.74	20	45	91・109
ADS & V-ADS	2.75	20	45	91・109

ストレートシャンクドリル早見表 φ2.75～φ4.35

単位 Unit : mm

型番 CODE NUMBER	径 Diameter φ D	刃長 Flute Length ℓ	全長 O.A.L L	詳細ページ Page
ADSL	2.75	28	64(65)	97
ADL		35	100	100
ADLL		50	150	103
ADS & V-ADS	2.76 ~ 2.79	20	45	91・109
ADS & V-ADS	2.8	20	45	91・109
ADSL		30	67(75)	97
ADL		35	100	100
ADLL		50	150	103
ACD		20	45	111
ADS & V-ADS	2.81 ~ 2.84	20	45	91・109
ADS & V-ADS	2.85	20	45	91・109
ADSL		30	67(75)	97
ADL		35	100	100
ADLL		50	150	103
ADS & V-ADS	2.86 ~ 2.89	20	45	91・109
ADS & V-ADS	2.9	20	45	91・109
ADSL		30	71(75)	98
ADL		35	100	101
ADLL		50	150	104
ACD		20	45	111
ADS & V-ADS	2.91 ~ 2.94	20	45	91・109
ADS & V-ADS	2.95	20	45	91・109
ADSL		30	71(75)	98
ADL		35	100	101
ADLL		50	150	104
ADS & V-ADS	2.96 ~ 2.99	20	45	91・109
ADS & V-ADS	3	20	45	91・109
ADSL		30	71(75)	98
ADL		50	100	101
ADLL		65	150	104
ACD		20	45	111
ADS	3.01 ~ 3.04	20	45	91
ADS & V-ADS	3.05	20	45	91・109
ADSL		30	71(75)	98
ADL		50	100	101
ADLL		65	150	104
ADS	3.06 ~ 3.09	20	45	91
ADS & V-ADS	3.1	25	50	91・109
ADSL		32	71(75)	98
ADL		50	100	101
ADLL		65	150	104
ACD		25	50	111
ADS	3.11 ~ 3.14	25	50	91
ADS & V-ADS	3.15	25	50	91・109

型番 CODE NUMBER	径 Diameter φ D	刃長 Flute Length ℓ	全長 O.A.L L	詳細ページ Page
ADSL	3.15	32	71(75)	98
ADL		50	100	101
ADLL		65	150	104
ADS	3.16 ~ 3.19	25	50	91
ADS & V-ADS	3.2	25	50	91・109
ADSL		32	71(75)	98
ADL		50	100	101
ADLL		65	150	104
ACD		25	50	111
ADS	3.21 ~ 3.24	25	50	91
ADS & V-ADS	3.25	25	50	91・109
ADSL		32	71(75)	98
ADL		50	100	101
ADLL		65	150	104
ADS	3.26 ~ 3.29	25	50	91
ADS & V-ADS	3.3	25	50	91・109
ADSL		35	73(75)	98
ADL		50	100	101
ADLL		65	150	104
ACD		25	50	111
ADS	3.31 ~ 3.34	25	50	91
ADS & V-ADS	3.35	25	50	91・109
ADSL		35	73(75)	98
ADL		50	100	101
ADLL		65	150	104
ADS	3.36 ~ 3.39	25	50	91
ADS & V-ADS	3.4	25	50	91・109
ADSL		35	73(75)	98
ADL		50	100	101
ADLL		65	150	104
ACD		25	50	111
ADS	3.41 ~ 3.44	25	50	91
ADS & V-ADS	3.45	25	50	91・109
ADSL		35	73(75)	98
ADL		50	100	101
ADLL		65	150	104
ADS	3.46 ~ 3.49	25	50	92
ADS & V-ADS	3.5	25	50	92・109
ADSL		35	73(75)	98
ADL		50	100	101
ADLL		65	150	104
ACD		25	50	111
ADS	3.51 ~ 3.54	25	50	92
ADS & V-ADS	3.55	25	50	92・109

ドリル早見表「ストレートシャンク」  
Simplified Drill Size Table

単位 Unit : mm

型番 CODE NUMBER	径 Diameter φ D	刃長 Flute Length ℓ	全長 O.A.L L	詳細ページ Page
ADSL	3.55	35	73(75)	98
ADL		50	100	101
ADLL		65	150	104
ADS	3.56 ~ 3.59	25	50	92
ADS & V-ADS	3.6	27	55	92・109
ADSL		37	76(80)	98
ADL		50	100	101
ADLL		75	150	104
ACD		27	55	111
ADS	3.61 ~ 3.64	27	55	92
ADS & V-ADS	3.65	27	55	92・109
ADSL		37	76(80)	98
ADL		50	100	101
ADLL		75	150	104
ADS	3.66 ~ 3.69	27	55	92
ADS & V-ADS	3.7	27	55	92・109
ADSL		37	76(80)	98
ADL		50	100	101
ADLL		75	150	104
ACD		27	55	111
ADS	3.71 ~ 3.74	27	55	92
ADS & V-ADS	3.75	27	55	92・109
ADSL		37	76(80)	98
ADL		50	100	101
ADLL		75	150	104
ADS	3.76 ~ 3.79	27	55	92
ADS & V-ADS	3.8	27	55	92・109
ADSL		37	76(80)	98
ADL		50	100	101
ADLL		75	150	104
ACD		27	55	111
ADS	3.81 ~ 3.84	27	55	92
ADS & V-ADS	3.85	27	55	92・109
ADSL		37	76(80)	98
ADL		50	100	101
ADLL		75	150	104
ADS	3.86 ~ 3.89	27	55	92
ADS & V-ADS	3.9	27	55	92・109
ADSL		37	79(80)	98
ADL		50	100	101
ADLL		75	150	104
ACD		27	55	111
ADS	3.91 ~ 3.94	27	55	92
ADS & V-ADS	3.95	27	55	92・109

型番 CODE NUMBER	径 Diameter φ D	刃長 Flute Length ℓ	全長 O.A.L L	詳細ページ Page
ADSL	3.95	37	79(80)	98
ADL		50	100	101
ADLL		75	150	104
ADS	3.96 ~ 3.99	27	55	92
ADS & V-ADS	4	27	55	92・109
ADSL		40	83(90)	98
ADL		50	100	101
ADLL		75	150	104
ACD		27	55	111
ADS	4.01 ~ 4.04	27	55	92
ADS & V-ADS	4.05	27	55	92・109
ADSL		40	83(90)	98
ADL		50	100	101
ADLL		75	150	104
ADS	4.06 ~ 4.09	27	55	92
ADS & V-ADS	4.1	30	60	92・109
ADSL		40	83(90)	98
ADL		50	100	101
ADLL		75	150	104
ACD		30	60	111
ADS	4.11 ~ 4.14	30	60	92
ADS & V-ADS	4.15	30	60	92・109
ADSL		40	83(90)	98
ADL		50	100	101
ADLL		75	150	104
ADS	4.16 ~ 4.19	30	60	92
ADS & V-ADS	4.2	30	60	92・109
ADSL		40	83(90)	98
ADL		50	100	101
ADLL		75	150	104
ACD		30	60	111
ADS	4.21 ~ 4.24	30	60	92
ADS & V-ADS	4.25	30	60	92・109
ADSL		40	83(90)	98
ADL		50	100	101
ADLL		75	150	104
ADS	4.26 ~ 4.29	30	60	92
ADS & V-ADS	4.3	30	60	92・109
ADSL		40	83(90)	98
ADL		50	100	101
ADLL		75	150	104
ACD		30	60	111
ADS	4.31 ~ 4.34	30	60	92
ADS & V-ADS	4.35	30	60	93・109

ストレートシャンクドリル早見表 φ4.35 ~ φ5.8

単位 Unit : mm

型番 CODE NUMBER	径 Diameter φ D	刃長 Flute Length ℓ	全長 O.A.L L	詳細ページ Page
ADSL	4.35	40	83(90)	98
ADL		50	100	101
ADLL		75	150	104
ADS	4.36 ~ 4.39	30	60	93
ADS & V-ADS	4.4	30	60	93・109
ADSL		42	86(90)	98
ADL		50	100	101
ADLL		75	150	104
ACD	4.41 ~ 4.44	30	60	111
ADS		30	60	93
ADS & V-ADS	4.45	30	60	93・109
ADSL		42	86(90)	98
ADL		50	100	101
ADLL		75	150	104
ADS	4.46 ~ 4.49	30	60	93
ADS & V-ADS	4.5	30	60	93・109
ADSL		42	86(90)	98
ADL		50	100	101
ADLL		75	150	104
ACD		30	60	111
ADS	4.51 ~ 4.54	30	60	93
ADS & V-ADS	4.55	30	60	93・109
ADSL		42	86(90)	98
ADL		50	100	101
ADLL		75	150	104
ADS	4.56 ~ 4.59	30	60	93
ADS & V-ADS	4.6	30	60	93・109
ADSL		42	86(90)	98
ADL		50	100	101
ADLL		75	150	104
ACD		30	60	111
ADS	4.61 ~ 4.64	30	60	93
ADS & V-ADS	4.65	30	60	93・109
ADSL		42	86(90)	98
ADL		50	100	101
ADLL		75	150	104
ADS	4.66 ~ 4.69	30	60	93
ADS & V-ADS	4.7	30	60	93・109
ADSL		42	89(90)	98
ADL		50	100	101
ADLL		75	150	104
ACD		30	60	111
ADS	4.71 ~ 4.74	30	60	93
ADS & V-ADS	4.75	30	60	93・109

型番 CODE NUMBER	径 Diameter φ D	刃長 Flute Length ℓ	全長 O.A.L L	詳細ページ Page
ADSL	4.75	42	89(90)	98
ADL		50	100	101
ADLL		75	150	104
ADS	4.76 ~ 4.79	30	60	93
ADS & V-ADS	4.8	30	60	93・109
ADSL		42	89(90)	98
ADL		50	100	101
ADLL		75	150	104
ACD	4.81 ~ 4.84	30	60	111
ADS		30	60	93
ADS & V-ADS	4.85	30	60	93・109
ADSL		42	89(90)	98
ADL		50	100	101
ADLL		75	150	104
ADS	4.86 ~ 4.89	30	60	93
ADS & V-ADS	4.9	30	60	93・109
ADSL		45	92(100)	98
ADL		50	100	101
ADLL		75	150	104
ACD		30	60	111
ADS	4.91 ~ 4.94	30	60	93
ADS & V-ADS	4.95	30	60	93・109
ADSL		45	92(100)	98
ADL		50	100	101
ADLL		75	150	104
ADS	4.96 ~ 4.99	30	60	93
ADS & V-ADS	5	30	60	93・109
ADSL		45	92(100)	98
ADL		75	150	101
ADLL		90	200	104
ACD		30	60	111
ADS	5.01 ~ 5.04	30	60	93
ADS & V-ADS	5.05	30	60	93・109
ADSL		45	92(100)	98
ADL		75	150	101
ADLL		90	200	104
ADS	5.06 ~ 5.09	30	60	93
V-ADS	5.1	40	80	109
ADS		40	65(80)	93
ADSL		45	92(100)	98
ADL		75	150	101
ADLL		90	200	104
ACD	40	65(80)	111	
ADS	5.11 ~ 5.14	40	65(80)	93

ドリル早見表「ストレートシャンク」  
Simplified Drill Size Table

単位 Unit : mm

型番 CODE NUMBER	径 Diameter φ D	刃長 Flute Length ℓ	全長 O.A.L L	詳細ページ Page
V-ADS	5.15	40	80	109
ADS		40	65(80)	93
ADSL		45	92(100)	98
ADL		75	150	101
ADLL		90	200	104
ADS	5.16 ~ 5.19	40	65(80)	93
V-ADS	5.2	40	80	109
ADS		40	65(80)	93
ADSL		45	95(100)	98
ADL		75	150	101
ADLL		90	200	104
ACD		40	65(80)	111
ADS	5.21 ~ 5.24	40	65(80)	93
V-ADS	5.25	40	80	109
ADS		40	65(80)	94
ADSL		45	95(100)	98
ADL		75	150	101
ADLL		90	200	104
ADS	5.26 ~ 5.29	40	65(80)	94
V-ADS	5.3	40	80	110
ADS		40	65(80)	94
ADSL		45	95(100)	98
ADL		75	150	101
ADLL		90	200	104
ACD		40	65(80)	111
ADS	5.31 ~ 5.34	40	65(80)	94
V-ADS	5.35	40	80	110
ADS		40	65(80)	94
ADSL		45	95(100)	98
ADL		75	150	101
ADLL		90	200	104
ADS	5.36 ~ 5.39	40	65(80)	94
V-ADS	5.4	40	80	110
ADS		40	65(80)	94
ADSL		45	95(100)	98
ADL		75	150	101
ADLL		90	200	104
ACD		40	65(80)	111
ADS	5.41 ~ 5.44	40	65(80)	94
V-ADS	5.45	40	80	110
ADS		40	65(80)	94
ADSL		45	95(100)	98
ADL		75	150	101
ADLL		90	200	104

型番 CODE NUMBER	径 Diameter φ D	刃長 Flute Length ℓ	全長 O.A.L L	詳細ページ Page
ADS	5.46 ~ 5.49	40	65(80)	94
V-ADS	5.5	40	80	110
ADS		40	65(80)	94
ADSL		45	95(100)	98
ADL		75	150	101
ADLL		90	200	104
ACD		40	65(80)	111
ADS	5.51 ~ 5.54	40	65(80)	94
V-ADS	5.55	40	80	110
ADS		40	65(80)	94
ADSL		45	95(100)	98
ADL		75	150	101
ADLL		90	200	104
ADS	5.56 ~ 5.59	40	65(80)	94
V-ADS	5.6	40	80	110
ADS		40	65(80)	94
ADSL		45	98(100)	98
ADL		75	150	101
ADLL		90	200	104
ACD		40	65(80)	111
ADS	5.61 ~ 5.64	40	65(80)	94
V-ADS	5.65	40	80	110
ADS		40	65(80)	94
ADSL		45	98(100)	98
ADL		75	150	101
ADLL		90	200	104
ADS	5.66 ~ 5.69	40	65(80)	94
V-ADS	5.7	40	80	110
ADS		40	65(80)	94
ADSL		45	98(100)	98
ADL		75	150	101
ADLL		90	200	104
ACD		40	65(80)	111
ADS	5.71 ~ 5.74	40	65(80)	94
V-ADS	5.75	40	80	110
ADS		40	65(80)	94
ADSL		45	98(100)	98
ADL		75	150	101
ADLL		90	200	104
ADS	5.76 ~ 5.79	40	65(80)	94
V-ADS	5.8	40	80	110
ADS		40	65(80)	94
ADSL		45	98(100)	98
ADL		75	150	101

ストレートシャンクドリル早見表 φ5.8～φ8.8

単位 Unit : mm

型番 CODE NUMBER	径 Diameter φ D	刃長 Flute Length ℓ	全長 O.A.L L	詳細ページ Page
ADLL	5.8	90	200	104
ACD		40	65(80)	111
ADS	5.81 ~ 5.84	40	65(80)	94
V-ADS	5.85	40	80	110
ADS		40	65(80)	94
ADSL		45	98(100)	98
ADL		75	150	101
ADLL		90	200	104
ADS		5.86 ~ 5.89	40	65(80)
V-ADS	5.9	40	80	110
ADS		40	65(80)	94
ADSL		45	98(100)	98
ADL		75	150	101
ADLL		90	200	104
ACD		40	65(80)	111
ADS	5.91 ~ 5.94	40	65(80)	94
V-ADS	5.95	40	80	110
ADS		40	65(80)	94
ADSL		45	98(100)	98
ADL		75	150	101
ADLL		90	200	104
ADS		5.96 ~ 5.99	40	65(80)
V-ADS	6	40	80	110
ADS		40	65(80)	94
ADSL		50	102(110)	98
ADL		75	150	101
ADLL		90	200	104
ACD		40	65(80)	111
ADS	6.01 ~ 6.09	40	65(80)	94
ADS	6.1	40	65(80)	95
ADSL		50	102(110)	98
ADL		75	150	101
ADLL		90	200	104
ACD		40	65(80)	111
ADS		6.15	40	65(80)
ADS	6.2	40	65(80)	95
ADSL		50	102(110)	98
ADL		75	150	101
ADLL		90	200	104
ACD		40	65(80)	112
ADS		6.25	40	65(80)
ADS	6.3	40	65(80)	95
ADSL		50	102(110)	98
ADL		75	150	101

型番 CODE NUMBER	径 Diameter φ D	刃長 Flute Length ℓ	全長 O.A.L L	詳細ページ Page
ADLL	6.3	90	200	104
ACD		40	65(80)	112
ADS	6.35	40	65(80)	95
ADS	6.4	40	65(80)	95
ADSL		50	105(110)	98
ADL		75	150	101
ADLL		90	200	104
ACD		40	65(80)	112
ADS		6.45	40	65(80)
ADS	6.5	40	65(80)	95
ADSL		50	105(110)	98
ADL		75	150	101
ADLL		90	200	104
ACD		40	65(80)	112
ADS		6.55	40	65(80)
ADS	6.6	40	65(80)	95
ADSL		50	105(110)	98
ADL		75	150	101
ADLL		90	200	104
ACD		40	65(80)	112
ADS		6.65	40	65(80)
ADS	6.7	40	65(80)	95
ADSL		50	105(110)	98
ADL		75	150	101
ADLL		90	200	104
ACD		40	65(80)	112
ADS		6.75	40	65(80)
ADS	6.8	40	65(80)	95
ADSL		50	105(110)	98
ADL		75	150	101
ADLL		90	200	104
ACD		40	65(80)	112
ADS		6.85	40	65(80)
ADS	6.9	40	65(80)	95
ADSL		50	105(110)	98
ADL		75	150	101
ADLL		90	200	104
ACD		40	65(80)	112
ADS		6.95	40	65(80)
ADS	7	40	65(80)	95
ADSL		50	105(110)	98
ADL		75	150	101
ADLL		90	200	104
ACD		40	65(80)	112

ドリル早見表「ストレートシャンク」  
Simplified Drill Size Table

単位 Unit : mm

型番 CODE NUMBER	径 Diameter φ D	刃長 Flute Length ℓ	全長 O.A.L L	詳細ページ Page
ADS	7.01 ~ 7.09	40	65(80)	95
ADS		40	80	95
ADSL	7.1	52	108(110)	98
ADL		75	150	101
ADLL		90	200	104
ACD	7.2	40	80	112
ADS		40	80	95
ADSL		52	108(110)	98
ADL		75	150	101
ADLL		90	200	104
ACD		40	80	112
ADS		7.3	40	80
ADSL	52		108(110)	98
ADL	75		150	101
ADLL	90		200	104
ACD	7.4	40	80	112
ADS		40	80	95
ADSL		52	111(120)	98
ADL		75	150	101
ADLL		90	200	104
ACD		40	80	112
ADS		7.5	40	80
ADSL	52		111(120)	98
ADL	75		150	101
ADLL	90		200	104
ACD	7.6	40	80	112
ADS		40	80	95
ADSL		52	111(120)	98
ADL		75	150	101
ADLL		90	200	104
ACD		40	80	112
ADS		7.7	40	80
ADSL	55		114(120)	98
ADL	75		150	101
ADLL	90		200	104
ACD	7.8	40	80	112
ADS		40	80	95
ADSL		55	114(120)	98
ADL		75	150	101
ADLL		90	200	104
ACD		40	80	112
ADS		7.9	40	80
ADSL	55		114(120)	98
ADL	75		150	101

型番 CODE NUMBER	径 Diameter φ D	刃長 Flute Length ℓ	全長 O.A.L L	詳細ページ Page
ADLL	7.9	90	200	104
ACD		40	80	112
ADS	8	40	80	95
ADSL		60	117(120)	98
ADL		75	150	101
ADLL		90	200	104
ACD		40	80	112
ADS	8.01 ~ 8.09	40	80	95
ADS	8.1	40	80	95
ADSL		60	117(120)	98
ADL		75	150	101
ADLL		90	200	104
ACD		40	80	112
ADS		8.2	40	80
ADSL	60		117(120)	98
ADL	75		150	101
ADLL	90		200	104
ACD	8.3	40	80	112
ADS		40	80	95
ADSL		60	117(120)	98
ADL		75	150	101
ADLL		90	200	104
ACD		40	80	112
ADS		8.4	40	80
ADSL	60		121(130)	98
ADL	75		150	101
ADLL	90		200	104
ACD	8.5	40	80	112
ADS		40	80	95
ADSL		60	121(130)	98
ADL		75	150	101
ADLL		90	200	104
ACD		40	80	112
ADS		8.6	40	80
ADSL	65		121(130)	99
ADL	75		150	102
ADLL	90		200	105
ACD	8.7	40	80	112
ADS		40	80	95
ADSL		65	121(130)	99
ADL		75	150	102
ADLL		90	200	105
ACD		40	80	112
ADS		8.8	40	80

ストレートシャンクドリル早見表 φ8.8～φ13

単位 Unit : mm

型番 CODE NUMBER	径 Diameter φ D	刃長 Flute Length ℓ	全長 O.A.L L	詳細ページ Page
ADSL	8.8	65	124(130)	99
ADL		75	150	102
ADLL		90	200	105
ACD	8.9	40	80	112
ADS		40	80	95
ADSL		65	124(130)	99
ADL		75	150	102
ADLL	9	90	200	105
ACD		40	80	112
ADS		40	80	95
ADSL		65	124(130)	99
ADL	9.01～9.09	75	150	102
ADLL		90	200	105
ACD		40	80	112
ADS		40	80	95
ADSL	9.1	65	124(130)	99
ADL		75	150	102
ADLL		90	200	105
ACD		40	80	112
ADS	9.2	40	80	95
ADSL		65	127(130)	99
ADL		75	150	102
ADLL		90	200	105
ACD	9.3	40	80	112
ADS		40	80	95
ADSL		65	127(130)	99
ADL		75	150	102
ADLL	9.4	90	200	105
ACD		40	80	112
ADS		40	80	95
ADSL		65	127(130)	99
ADL	9.5	75	150	102
ADLL		90	200	105
ACD		40	80	112
ADS		50	100	95
ADSL	9.6	65	130	99
ADL		75	150	102
ADLL		90	200	105

型番 CODE NUMBER	径 Diameter φ D	刃長 Flute Length ℓ	全長 O.A.L L	詳細ページ Page
ACD	9.6	50	100	112
ADS	9.7	50	100	95
ADSL		65	130	99
ADL		75	150	102
ADLL	9.8	90	200	105
ACD		50	100	112
ADS		50	100	95
ADSL	9.9	65	130	99
ADL		75	150	102
ADLL		90	200	105
ACD		50	100	112
ADS	10	50	100	95
ADSL		65	130	99
ADL		75	150	102
ADLL		90	200	105
ACD	10.01～10.09	90	200	105
ADS		50	100	112
ADSL		50	100	95
ADL		70	130	99
ADLL	10.1～10.4	75	150	102
ACD		90	200	105
ADS		50	100	112
ADSL		50	100	95
ADL	10.5	50	100	95
ADLL		70	137(150)	99
ACD		90	200	102
ADS		120	250	105
ADSL	10.6～10.9	50	100	112
ADL		50	100	96
ADLL		70	140(150)	99
ACD		90	200	102
ADS	11	120	250	105
ADSL		50	100	112
ADL		50	100	96
ADLL		70	140(150)	99
ACD	11.01～11.09	90	200	102
ADS		50	100	112
ADSL		50	100	96
ADL		70	143(150)	99
ADLL	11.1～11.4	90	200	102
ACD		120	250	105
ADS		50	100	112
ADSL		50	100	96
ADL	11.5	50	100	96
ADLL		70	143(150)	99
ACD		90	200	102
ADS		120	250	105
ADSL	11.6～11.9	50	100	112
ADL		50	100	96
ADLL		50	100	96
ACD		70	149(150)	99

ドリル早見表「ストレートシャンク」  
Simplified Drill Size Table





**MEMO**

---

A series of horizontal dashed lines for writing, spanning the width of the page.

# 超硬ドリル

SOLID CARBIDE DRILL

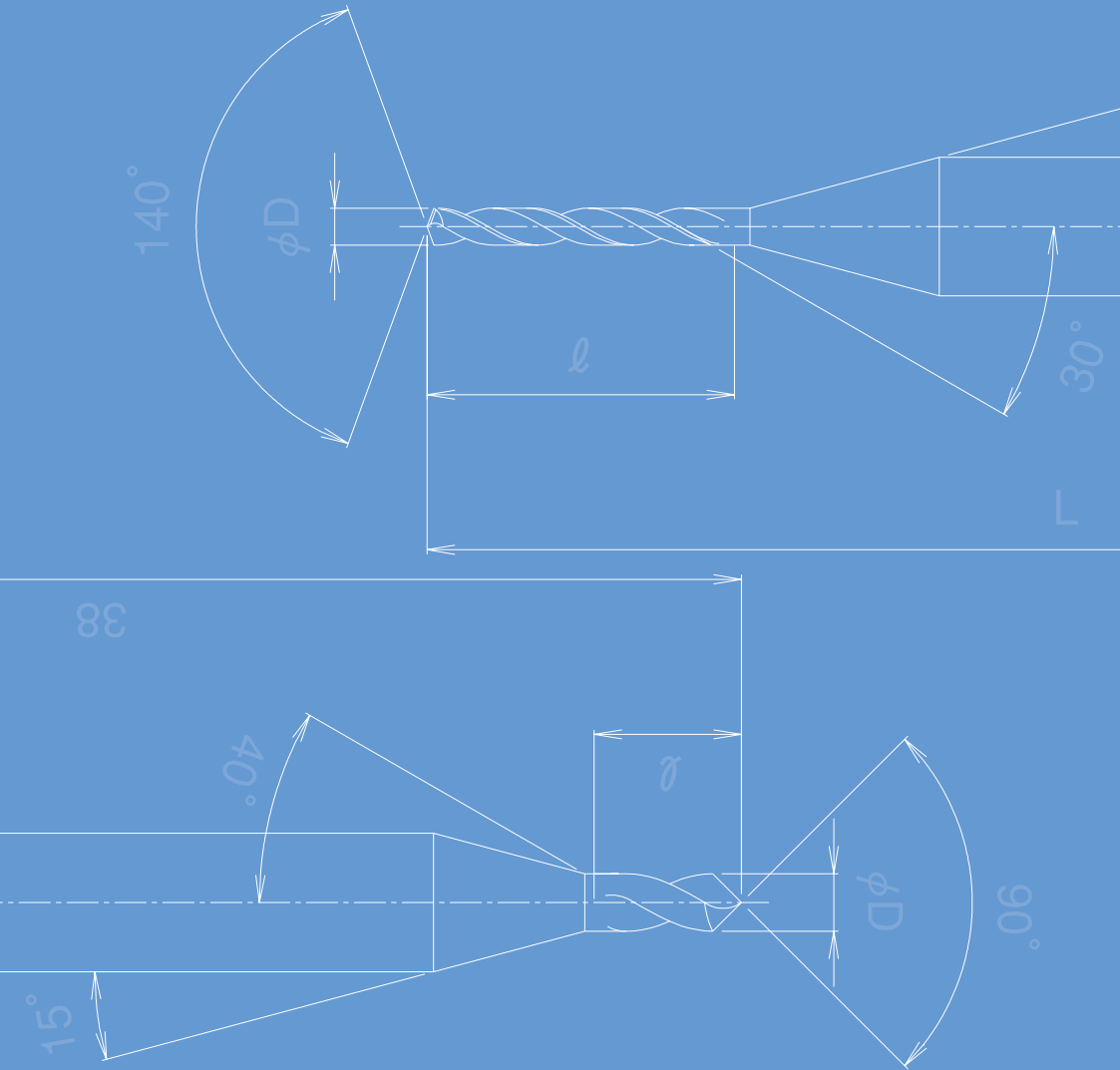

# ルーマドリル ショート刃

Micro Drill Short Flute Length

## ADRS

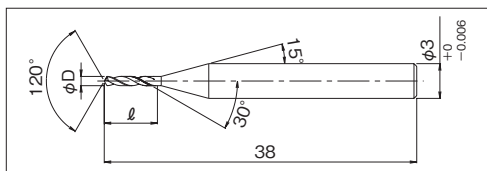

■ 精密・多孔細穴加工用ドリルです。

Best for drilling precision small holes.

■ 一般鋼材から非鉄、樹脂まで幅広い適用が可能です。

Wide application available covering from steel to non-ferrous and resin.

刃径公差：+0~-0.005

φD Tolerance

型番 CODE NUMBER	径 φD	刃長 ℓ	全長 L	シャンク d	定価 ¥
ADRS-0010	0.1	0.6	38	3	5,400
ADRS-0011	0.11	0.6	38	3	5,400
ADRS-0012	0.12	0.6	38	3	5,400
ADRS-0013	0.13	0.6	38	3	5,400
ADRS-0014	0.14	0.6	38	3	5,400
ADRS-0015	0.15	0.8	38	3	5,400
ADRS-0016	0.16	0.8	38	3	5,400
ADRS-0017	0.17	0.8	38	3	5,400
ADRS-0018	0.18	1	38	3	4,900
ADRS-0019	0.19	1	38	3	4,900
ADRS-0020	0.2	1	38	3	4,900
ADRS-0021	0.21	1	38	3	4,440
ADRS-0022	0.22	1.2	38	3	4,440
ADRS-0023	0.23	1.2	38	3	4,440
ADRS-0024	0.24	1.2	38	3	4,440
ADRS-0025	0.25	1.5	38	3	4,440
ADRS-0026	0.26	1.5	38	3	4,440
ADRS-0027	0.27	1.5	38	3	4,440
ADRS-0028	0.28	1.5	38	3	4,440
ADRS-0029	0.29	1.5	38	3	4,440
ADRS-0030	0.3	2.5	38	3	4,440
ADRS-0031	0.31	2.5	38	3	3,340
ADRS-0032	0.32	2.5	38	3	3,340
ADRS-0033	0.33	2.5	38	3	3,340
ADRS-0034	0.34	2.5	38	3	3,340
ADRS-0035	0.35	2.5	38	3	3,340



単位 Unit : mm

型番 CODE NUMBER	径 φD	刃長 ℓ	全長 L	シャンク d	定価 ¥
ADRS-0036	0.36	2.5	38	3	3,340
ADRS-0037	0.37	2.5	38	3	3,340
ADRS-0038	0.38	2.5	38	3	3,340
ADRS-0039	0.39	2.5	38	3	3,340
ADRS-0040	0.4	3	38	3	3,340
ADRS-0041	0.41	3	38	3	3,340
ADRS-0042	0.42	3	38	3	3,340
ADRS-0043	0.43	3	38	3	3,340
ADRS-0044	0.44	3	38	3	3,340
ADRS-0045	0.45	3	38	3	3,340
ADRS-0046	0.46	3	38	3	3,340
ADRS-0047	0.47	3	38	3	3,340
ADRS-0048	0.48	3	38	3	3,340
ADRS-0049	0.49	3	38	3	3,340
ADRS-0050	0.5	3	38	3	3,340
ADRS-0051	0.51	3	38	3	3,340
ADRS-0052	0.52	3	38	3	3,340
ADRS-0053	0.53	3	38	3	3,340
ADRS-0054	0.54	3	38	3	3,340
ADRS-0055	0.55	3	38	3	3,340
ADRS-0056	0.56	3	38	3	3,340
ADRS-0057	0.57	3	38	3	3,340
ADRS-0058	0.58	3	38	3	3,340
ADRS-0059	0.59	3	38	3	3,340
ADRS-0060	0.6	3	38	3	3,340
ADRS-0061	0.61	3	38	3	3,340

単位 Unit : mm

型番 CODE NUMBER	径 φD	刃長 ℓ	全長 L	シャンク d	定価 ¥
ADRS-0062	0.62	3	38	3	3,340
ADRS-0063	0.63	3	38	3	3,340
ADRS-0064	0.64	3	38	3	3,340
ADRS-0065	0.65	3	38	3	3,340
ADRS-0066	0.66	3	38	3	3,340
ADRS-0067	0.67	3	38	3	3,340
ADRS-0068	0.68	3	38	3	3,340
ADRS-0069	0.69	3	38	3	3,340
ADRS-0070	0.7	4	38	3	3,340
ADRS-0071	0.71	4	38	3	3,340
ADRS-0072	0.72	4	38	3	3,340
ADRS-0073	0.73	4	38	3	3,340
ADRS-0074	0.74	4	38	3	3,340
ADRS-0075	0.75	4	38	3	3,340
ADRS-0076	0.76	4	38	3	3,340
ADRS-0077	0.77	4	38	3	3,340
ADRS-0078	0.78	4	38	3	3,340
ADRS-0079	0.79	4	38	3	3,340
ADRS-0080	0.8	4	38	3	3,340
ADRS-0081	0.81	4	38	3	3,340
ADRS-0082	0.82	4	38	3	3,340
ADRS-0083	0.83	4	38	3	3,340
ADRS-0084	0.84	4	38	3	3,340
ADRS-0085	0.85	4	38	3	3,340
ADRS-0086	0.86	4	38	3	3,340
ADRS-0087	0.87	4	38	3	3,340
ADRS-0088	0.88	4	38	3	3,340
ADRS-0089	0.89	4	38	3	3,340
ADRS-0090	0.9	4	38	3	3,340
ADRS-0091	0.91	4	38	3	3,340
ADRS-0092	0.92	4	38	3	3,340
ADRS-0093	0.93	4	38	3	3,340
ADRS-0094	0.94	4	38	3	3,340
ADRS-0095	0.95	4	38	3	3,340
ADRS-0096	0.96	4	38	3	3,340
ADRS-0097	0.97	4	38	3	3,340
ADRS-0098	0.98	4	38	3	3,340
ADRS-0099	0.99	4	38	3	3,340
ADRS-0100	1.0	5	38	3	3,340
ADRS-0101	1.01	5	38	3	3,340
ADRS-0102	1.02	5	38	3	3,340
ADRS-0103	1.03	5	38	3	3,340
ADRS-0104	1.04	5	38	3	3,340
ADRS-0105	1.05	5	38	3	3,340

型番 CODE NUMBER	径 φD	刃長 ℓ	全長 L	シャンク d	定価 ¥
ADRS-0106	1.06	5	38	3	3,340
ADRS-0107	1.07	5	38	3	3,340
ADRS-0108	1.08	5	38	3	3,340
ADRS-0109	1.09	5	38	3	3,340
ADRS-0110	1.1	5	38	3	3,340
ADRS-0111	1.11	5	38	3	3,340
ADRS-0112	1.12	5	38	3	3,340
ADRS-0113	1.13	5	38	3	3,340
ADRS-0114	1.14	5	38	3	3,340
ADRS-0115	1.15	5	38	3	3,340
ADRS-0116	1.16	5	38	3	3,340
ADRS-0117	1.17	5	38	3	3,340
ADRS-0118	1.18	5	38	3	3,340
ADRS-0119	1.19	5	38	3	3,340
ADRS-0120	1.2	5	38	3	3,340
ADRS-0121	1.21	5	38	3	3,340
ADRS-0122	1.22	5	38	3	3,340
ADRS-0123	1.23	5	38	3	3,340
ADRS-0124	1.24	5	38	3	3,340
ADRS-0125	1.25	5	38	3	3,340
ADRS-0126	1.26	5	38	3	3,340
ADRS-0127	1.27	5	38	3	3,340
ADRS-0128	1.28	5	38	3	3,340
ADRS-0129	1.29	5	38	3	3,340
ADRS-0130	1.3	5	38	3	3,340
ADRS-0131	1.31	5	38	3	3,340
ADRS-0132	1.32	5	38	3	3,340
ADRS-0133	1.33	5	38	3	3,340
ADRS-0134	1.34	5	38	3	3,340
ADRS-0135	1.35	5	38	3	3,340
ADRS-0136	1.36	5	38	3	3,340
ADRS-0137	1.37	5	38	3	3,340
ADRS-0138	1.38	5	38	3	3,340
ADRS-0139	1.39	5	38	3	3,340
ADRS-0140	1.4	5	38	3	3,340
ADRS-0141	1.41	5	38	3	3,340
ADRS-0142	1.42	5	38	3	3,340
ADRS-0143	1.43	5	38	3	3,340
ADRS-0144	1.44	5	38	3	3,340
ADRS-0145	1.45	5	38	3	3,340
ADRS-0146	1.46	5	38	3	3,340
ADRS-0147	1.47	5	38	3	3,340
ADRS-0148	1.48	5	38	3	3,340
ADRS-0149	1.49	5	38	3	3,340

Next Page ▶

型番 CODE NUMBER	径 φD	刃長 ℓ	全長 L	シャンク d	定価 ¥
ADRS-0150	1.5	5	38	3	3,340
ADRS-0151	1.51	5	38	3	3,340
ADRS-0152	1.52	5	38	3	3,340
ADRS-0153	1.53	5	38	3	3,340
ADRS-0154	1.54	5	38	3	3,340
ADRS-0155	1.55	5	38	3	3,340
ADRS-0156	1.56	5	38	3	3,340
ADRS-0157	1.57	5	38	3	3,340
ADRS-0158	1.58	5	38	3	3,340
ADRS-0159	1.59	5	38	3	3,340
ADRS-0160	1.6	10	38	3	3,340
ADRS-0161	1.61	10	38	3	3,870
ADRS-0162	1.62	10	38	3	3,870
ADRS-0163	1.63	10	38	3	3,870
ADRS-0164	1.64	10	38	3	3,870
ADRS-0165	1.65	10	38	3	3,870
ADRS-0166	1.66	10	38	3	3,870
ADRS-0167	1.67	10	38	3	3,870
ADRS-0168	1.68	10	38	3	3,870
ADRS-0169	1.69	10	38	3	3,870
ADRS-0170	1.7	10	38	3	3,870
ADRS-0171	1.71	10	38	3	3,870
ADRS-0172	1.72	10	38	3	3,870
ADRS-0173	1.73	10	38	3	3,870
ADRS-0174	1.74	10	38	3	3,870
ADRS-0175	1.75	10	38	3	3,870
ADRS-0176	1.76	10	38	3	3,870
ADRS-0177	1.77	10	38	3	3,870
ADRS-0178	1.78	10	38	3	3,870
ADRS-0179	1.79	10	38	3	3,870
ADRS-0180	1.8	10	38	3	3,870
ADRS-0181	1.81	10	38	3	3,870
ADRS-0182	1.82	10	38	3	3,870
ADRS-0183	1.83	10	38	3	3,870
ADRS-0184	1.84	10	38	3	3,870
ADRS-0185	1.85	10	38	3	3,870
ADRS-0186	1.86	10	38	3	3,870
ADRS-0187	1.87	10	38	3	3,870
ADRS-0188	1.88	10	38	3	3,870
ADRS-0189	1.89	10	38	3	3,870
ADRS-0190	1.9	10	38	3	3,870
ADRS-0191	1.91	10	38	3	3,870
ADRS-0192	1.92	10	38	3	3,870
ADRS-0193	1.93	10	38	3	3,870

型番 CODE NUMBER	径 φD	刃長 ℓ	全長 L	シャンク d	定価 ¥
ADRS-0194	1.94	10	38	3	3,870
ADRS-0195	1.95	10	38	3	3,870
ADRS-0196	1.96	10	38	3	3,870
ADRS-0197	1.97	10	38	3	3,870
ADRS-0198	1.98	10	38	3	3,870
ADRS-0199	1.99	10	38	3	3,870
ADRS-0200	2	10	38	3	3,870
ADRS-0201	2.01	10	38	3	3,870
ADRS-0202	2.02	10	38	3	3,870
ADRS-0203	2.03	10	38	3	3,870
ADRS-0204	2.04	10	38	3	3,870
ADRS-0205	2.05	10	38	3	3,870
ADRS-0206	2.06	10	38	3	3,870
ADRS-0207	2.07	10	38	3	3,870
ADRS-0208	2.08	10	38	3	3,870
ADRS-0209	2.09	10	38	3	3,870
ADRS-0210	2.1	10	38	3	3,870
ADRS-0211	2.11	10	38	3	3,870
ADRS-0212	2.12	10	38	3	3,870
ADRS-0213	2.13	10	38	3	3,870
ADRS-0214	2.14	10	38	3	3,870
ADRS-0215	2.15	10	38	3	3,870
ADRS-0216	2.16	10	38	3	3,870
ADRS-0217	2.17	10	38	3	3,870
ADRS-0218	2.18	10	38	3	3,870
ADRS-0219	2.19	10	38	3	3,870
ADRS-0220	2.2	10	38	3	4,090
ADRS-0221	2.21	10	38	3	4,090
ADRS-0222	2.22	10	38	3	4,090
ADRS-0223	2.23	10	38	3	4,090
ADRS-0224	2.24	10	38	3	4,090
ADRS-0225	2.25	10	38	3	4,090
ADRS-0226	2.26	10	38	3	4,090
ADRS-0227	2.27	10	38	3	4,090
ADRS-0228	2.28	10	38	3	4,090
ADRS-0229	2.29	10	38	3	4,090
ADRS-0230	2.3	10	38	3	4,090
ADRS-0231	2.31	10	38	3	4,090
ADRS-0232	2.32	10	38	3	4,090
ADRS-0233	2.33	10	38	3	4,090
ADRS-0234	2.34	10	38	3	4,090
ADRS-0235	2.35	10	38	3	4,090
ADRS-0236	2.36	10	38	3	4,090
ADRS-0237	2.37	10	38	3	4,090



# ルーマドリル 標準刃長

Micro Drill Regular Flute Length

## ADR

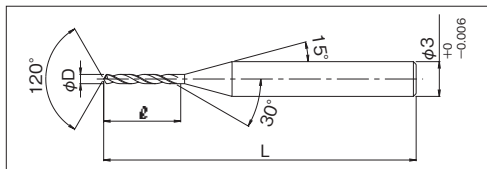

φ0.02～φ0.04は首逃げ2段形状です。

■ 精密・多孔細穴加工用ドリルです。(最小径φ0.02)

Best for drilling precision small holes.(smallest diameter φ0.02)

■ 一般鋼材から非鉄、樹脂まで幅広い適用が可能です。

Wide application available covering from steel to non-ferrous and resin.

刃径公差：+0～-0.005

φD Tolerance



単位 Unit : mm

型番 CODE NUMBER	径 φD	刃長 ℓ	全長 L	シャンク d	定価 ¥
ADR-0002	0.02	0.2	38	3	28,000
ADR-0003	0.03	0.3	38	3	20,000
ADR-0004	0.04	0.4	38	3	13,490
ADR-0005	0.05	0.5	38	3	11,350
ADR-0006	0.06	0.6	38	3	10,400
ADR-0007	0.07	0.7	38	3	9,400
ADR-0008	0.08	0.8	38	3	7,990
ADR-0009	0.09	0.9	38	3	7,040
ADR-0010	0.1	1.2	38	3	5,400
ADR-0011	0.11	1.2	38	3	5,400
ADR-0012	0.12	1.4	38	3	5,400
ADR-0013	0.13	1.4	38	3	5,400
ADR-0014	0.14	1.4	38	3	5,400
ADR-0015	0.15	1.8	38	3	5,400
ADR-0016	0.16	1.8	38	3	5,400
ADR-0017	0.17	1.8	38	3	5,400
ADR-0018	0.18	2.1	38	3	4,900
ADR-0019	0.19	2.1	38	3	4,900
ADR-0020	0.2	2.4	38	3	4,900
ADR-0021	0.21	2.4	38	3	4,440
ADR-0022	0.22	2.6	38	3	4,440
ADR-0023	0.23	2.6	38	3	4,440
ADR-0024	0.24	2.6	38	3	4,440
ADR-0025	0.25	3	38	3	4,440
ADR-0026	0.26	3	38	3	4,440
ADR-0027	0.27	3	38	3	4,440

型番 CODE NUMBER	径 φD	刃長 ℓ	全長 L	シャンク d	定価 ¥
ADR-0028	0.28	3.3	38	3	4,440
ADR-0029	0.29	3.3	38	3	4,440
ADR-0030	0.3	5	38	3	4,440
ADR-0031	0.31	5	38	3	3,340
ADR-0032	0.32	5	38	3	3,340
ADR-0033	0.33	5	38	3	3,340
ADR-0034	0.34	5	38	3	3,340
ADR-0035	0.35	5	38	3	3,340
ADR-0036	0.36	5	38	3	3,340
ADR-0037	0.37	5	38	3	3,340
ADR-0038	0.38	5	38	3	3,340
ADR-0039	0.39	5	38	3	3,340
ADR-0040	0.4	6	38	3	3,340
ADR-0041	0.41	6	38	3	3,340
ADR-0042	0.42	6	38	3	3,340
ADR-0043	0.43	6	38	3	3,340
ADR-0044	0.44	6	38	3	3,340
ADR-0045	0.45	6	38	3	3,340
ADR-0046	0.46	6	38	3	3,340
ADR-0047	0.47	6	38	3	3,340
ADR-0048	0.48	6	38	3	3,340
ADR-0049	0.49	6	38	3	3,340
ADR-0050	0.5	6	38	3	3,340
ADR-0051	0.51	6	38	3	3,340
ADR-0052	0.52	6	38	3	3,340
ADR-0053	0.53	6	38	3	3,340



単位 Unit : mm

型番 CODE NUMBER	径 φD	刃長 ℓ	全長 L	シャンク d	定価 ¥
ADR-0054	0.54	6	38	3	3,340
ADR-0055	0.55	6	38	3	3,340
ADR-0056	0.56	6	38	3	3,340
ADR-0057	0.57	6	38	3	3,340
ADR-0058	0.58	6	38	3	3,340
ADR-0059	0.59	6	38	3	3,340
ADR-0060	0.6	7	38	3	3,340
ADR-0061	0.61	7	38	3	3,340
ADR-0062	0.62	7	38	3	3,340
ADR-0063	0.63	7	38	3	3,340
ADR-0064	0.64	7	38	3	3,340
ADR-0065	0.65	7	38	3	3,340
ADR-0066	0.66	7	38	3	3,340
ADR-0067	0.67	7	38	3	3,340
ADR-0068	0.68	7	38	3	3,340
ADR-0069	0.69	7	38	3	3,340
ADR-0070	0.7	8	38	3	3,340
ADR-0071	0.71	8	38	3	3,340
ADR-0072	0.72	8	38	3	3,340
ADR-0073	0.73	8	38	3	3,340
ADR-0074	0.74	8	38	3	3,340
ADR-0075	0.75	8	38	3	3,340
ADR-0076	0.76	8	38	3	3,340
ADR-0077	0.77	8	38	3	3,340
ADR-0078	0.78	8	38	3	3,340
ADR-0079	0.79	8	38	3	3,340
ADR-0080	0.8	8	38	3	3,340
ADR-0081	0.81	8	38	3	3,340
ADR-0082	0.82	8	38	3	3,340
ADR-0083	0.83	8	38	3	3,340
ADR-0084	0.84	8	38	3	3,340
ADR-0085	0.85	8	38	3	3,340
ADR-0086	0.86	8	38	3	3,340
ADR-0087	0.87	8	38	3	3,340
ADR-0088	0.88	8	38	3	3,340
ADR-0089	0.89	8	38	3	3,340
ADR-0090	0.9	8	38	3	3,340
ADR-0091	0.91	8	38	3	3,340
ADR-0092	0.92	8	38	3	3,340
ADR-0093	0.93	8	38	3	3,340
ADR-0094	0.94	8	38	3	3,340
ADR-0095	0.95	8	38	3	3,340
ADR-0096	0.96	8	38	3	3,340
ADR-0097	0.97	8	38	3	3,340

型番 CODE NUMBER	径 φD	刃長 ℓ	全長 L	シャンク d	定価 ¥
ADR-0098	0.98	8	38	3	3,340
ADR-0099	0.99	8	38	3	3,340
ADR-0100	1	10	38	3	3,340
ADR-0101	1.01	10	38	3	3,340
ADR-0102	1.02	10	38	3	3,340
ADR-0103	1.03	10	38	3	3,340
ADR-0104	1.04	10	38	3	3,340
ADR-0105	1.05	10	38	3	3,340
ADR-0106	1.06	10	38	3	3,340
ADR-0107	1.07	10	38	3	3,340
ADR-0108	1.08	10	38	3	3,340
ADR-0109	1.09	10	38	3	3,340
ADR-0110	1.1	10	38	3	3,340
ADR-0111	1.11	10	38	3	3,340
ADR-0112	1.12	10	38	3	3,340
ADR-0113	1.13	10	38	3	3,340
ADR-0114	1.14	10	38	3	3,340
ADR-0115	1.15	10	38	3	3,340
ADR-0116	1.16	10	38	3	3,340
ADR-0117	1.17	10	38	3	3,340
ADR-0118	1.18	10	38	3	3,340
ADR-0119	1.19	10	38	3	3,340
ADR-0120	1.2	10	38	3	3,340
ADR-0121	1.21	10	38	3	3,340
ADR-0122	1.22	10	38	3	3,340
ADR-0123	1.23	10	38	3	3,340
ADR-0124	1.24	10	38	3	3,340
ADR-0125	1.25	10	38	3	3,340
ADR-0126	1.26	10	38	3	3,340
ADR-0127	1.27	10	38	3	3,340
ADR-0128	1.28	10	38	3	3,340
ADR-0129	1.29	10	38	3	3,340
ADR-0130	1.3	10	38	3	3,340
ADR-0131	1.31	10	38	3	3,340
ADR-0132	1.32	10	38	3	3,340
ADR-0133	1.33	10	38	3	3,340
ADR-0134	1.34	10	38	3	3,340
ADR-0135	1.35	10	38	3	3,340
ADR-0136	1.36	10	38	3	3,340
ADR-0137	1.37	10	38	3	3,340
ADR-0138	1.38	10	38	3	3,340
ADR-0139	1.39	10	38	3	3,340
ADR-0140	1.4	10	38	3	3,340
ADR-0141	1.41	10	38	3	3,340

Next Page ▶

型番 CODE NUMBER	径 φD	刃長 ℓ	全長 L	シャンク d	定価 ¥
ADR-0142	1.42	10	38	3	3,340
ADR-0143	1.43	10	38	3	3,340
ADR-0144	1.44	10	38	3	3,340
ADR-0145	1.45	10	38	3	3,340
ADR-0146	1.46	10	38	3	3,340
ADR-0147	1.47	10	38	3	3,340
ADR-0148	1.48	10	38	3	3,340
ADR-0149	1.49	10	38	3	3,340
ADR-0150	1.5	10	38	3	3,340
ADR-0151	1.51	10	38	3	3,340
ADR-0152	1.52	10	38	3	3,340
ADR-0153	1.53	10	38	3	3,340
ADR-0154	1.54	10	38	3	3,340
ADR-0155	1.55	10	38	3	3,340
ADR-0156	1.56	10	38	3	3,340
ADR-0157	1.57	10	38	3	3,340
ADR-0158	1.58	10	38	3	3,340
ADR-0159	1.59	10	38	3	3,340
ADR-0160	1.6	22	50	3	3,340
ADR-0161	1.61	22	50	3	3,870
ADR-0162	1.62	22	50	3	3,870
ADR-0163	1.63	22	50	3	3,870
ADR-0164	1.64	22	50	3	3,870
ADR-0165	1.65	22	50	3	3,870
ADR-0166	1.66	22	50	3	3,870
ADR-0167	1.67	22	50	3	3,870
ADR-0168	1.68	22	50	3	3,870
ADR-0169	1.69	22	50	3	3,870
ADR-0170	1.7	22	50	3	3,870
ADR-0171	1.71	22	50	3	3,870
ADR-0172	1.72	22	50	3	3,870
ADR-0173	1.73	22	50	3	3,870
ADR-0174	1.74	22	50	3	3,870
ADR-0175	1.75	22	50	3	3,870
ADR-0176	1.76	22	50	3	3,870
ADR-0177	1.77	22	50	3	3,870
ADR-0178	1.78	22	50	3	3,870
ADR-0179	1.79	22	50	3	3,870
ADR-0180	1.8	22	50	3	3,870
ADR-0181	1.81	22	50	3	3,870
ADR-0182	1.82	22	50	3	3,870
ADR-0183	1.83	22	50	3	3,870
ADR-0184	1.84	22	50	3	3,870
ADR-0185	1.85	22	50	3	3,870

型番 CODE NUMBER	径 φD	刃長 ℓ	全長 L	シャンク d	定価 ¥
ADR-0186	1.86	22	50	3	3,870
ADR-0187	1.87	22	50	3	3,870
ADR-0188	1.88	22	50	3	3,870
ADR-0189	1.89	22	50	3	3,870
ADR-0190	1.9	22	50	3	3,870
ADR-0191	1.91	22	50	3	3,870
ADR-0192	1.92	22	50	3	3,870
ADR-0193	1.93	22	50	3	3,870
ADR-0194	1.94	22	50	3	3,870
ADR-0195	1.95	22	50	3	3,870
ADR-0196	1.96	22	50	3	3,870
ADR-0197	1.97	22	50	3	3,870
ADR-0198	1.98	22	50	3	3,870
ADR-0199	1.99	22	50	3	3,870
ADR-0200	2	22	50	3	3,870
ADR-0201	2.01	22	50	3	3,870
ADR-0202	2.02	22	50	3	3,870
ADR-0203	2.03	22	50	3	3,870
ADR-0204	2.04	22	50	3	3,870
ADR-0205	2.05	22	50	3	3,870
ADR-0206	2.06	22	50	3	3,870
ADR-0207	2.07	22	50	3	3,870
ADR-0208	2.08	22	50	3	3,870
ADR-0209	2.09	22	50	3	3,870
ADR-0210	2.1	22	50	3	3,870
ADR-0211	2.11	22	50	3	3,870
ADR-0212	2.12	22	50	3	3,870
ADR-0213	2.13	22	50	3	3,870
ADR-0214	2.14	22	50	3	3,870
ADR-0215	2.15	22	50	3	3,870
ADR-0216	2.16	22	50	3	3,870
ADR-0217	2.17	22	50	3	3,870
ADR-0218	2.18	22	50	3	3,870
ADR-0219	2.19	22	50	3	3,870
ADR-0220	2.2	22	50	3	4,090
ADR-0221	2.21	22	50	3	4,090
ADR-0222	2.22	22	50	3	4,090
ADR-0223	2.23	22	50	3	4,090
ADR-0224	2.24	22	50	3	4,090
ADR-0225	2.25	22	50	3	4,090
ADR-0226	2.26	22	50	3	4,090
ADR-0227	2.27	22	50	3	4,090
ADR-0228	2.28	22	50	3	4,090
ADR-0229	2.29	22	50	3	4,090



# ルーマドリル セミロング刃

Micro Drill Semi Long Flute Length

## ADRSL

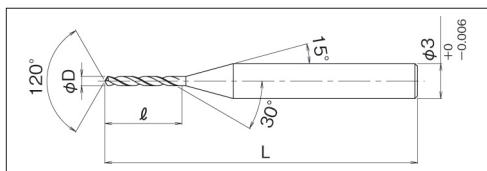

φ0.03～φ0.04は首逃げ2段形状です。

■ 精密・多孔細穴加工用ドリルです。(最小径φ0.03)

Best for drilling precision small holes. (smallest diameter φ0.03)

■ 一般鋼材から非鉄、樹脂まで幅広い適用が可能です。

Wide application available covering from steel to non-ferrous and resin.

刃径公差：+0～-0.005

φ D Tolerance

型番 CODE NUMBER	径 φD	刃長 ℓ	全長 L	シャンク d	定価 ¥
ADRSL-0003	0.03	0.5	38	3	20,800
ADRSL-0004	0.04	0.6	38	3	14,640
ADRSL-0005	0.05	0.8	38	3	12,550
ADRSL-0006	0.06	0.8	38	3	11,020
ADRSL-0007	0.07	1.1	38	3	10,200
ADRSL-0008	0.08	1.2	38	3	8,700
ADRSL-0009	0.09	1.2	38	3	7,680
ADRSL-0010	0.1	1.9	38	3	5,620
ADRSL-0011	0.11	1.9	38	3	5,450
ADRSL-0012	0.12	2.2	38	3	5,450
ADRSL-0013	0.13	2.2	38	3	5,450
ADRSL-0014	0.14	2.2	38	3	5,450
ADRSL-0015	0.15	2.9	38	3	5,450
ADRSL-0016	0.16	2.9	38	3	5,450
ADRSL-0017	0.17	3.2	38	3	5,450
ADRSL-0018	0.18	3.3	38	3	5,060
ADRSL-0019	0.19	3.3	38	3	5,060
ADRSL-0020	0.2	4	38	3	5,060
ADRSL-0021	0.21	4	38	3	4,650
ADRSL-0022	0.22	4.3	38	3	4,650
ADRSL-0023	0.23	4.3	38	3	4,650
ADRSL-0024	0.24	4.3	38	3	4,650



単位 Unit : mm

型番 CODE NUMBER	径 φD	刃長 ℓ	全長 L	シャンク d	定価 ¥
ADRSL-0025	0.25	5	38	3	4,650
ADRSL-0026	0.26	5	38	3	4,650
ADRSL-0027	0.27	5	38	3	4,650
ADRSL-0028	0.28	5.2	38	3	4,650
ADRSL-0029	0.29	5.2	38	3	4,650
ADRSL-0030	0.3	7	38	3	4,540
ADRSL-0031	0.31	7	38	3	3,790
ADRSL-0032	0.32	7	38	3	3,790
ADRSL-0033	0.33	7	38	3	3,790
ADRSL-0034	0.34	7	38	3	3,790
ADRSL-0035	0.35	7	38	3	3,790
ADRSL-0036	0.36	7	38	3	3,790
ADRSL-0037	0.37	7	38	3	3,790
ADRSL-0038	0.38	7	38	3	3,790
ADRSL-0039	0.39	7	38	3	3,790
ADRSL-0040	0.4	9	38	3	3,790
ADRSL-0041	0.41	9	38	3	3,790
ADRSL-0042	0.42	9	38	3	3,790
ADRSL-0043	0.43	9	38	3	3,790
ADRSL-0044	0.44	9	38	3	3,790
ADRSL-0045	0.45	9	38	3	3,790
ADRSL-0046	0.46	9	38	3	3,790



# ルーマドリル ロング刃

Micro Drill Long Flute Length

## ADRL

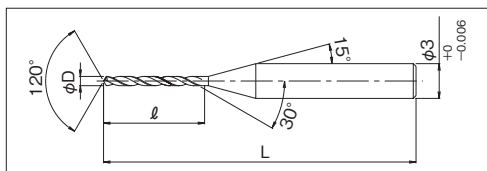

φ0.03～φ0.04は首逃げ2段形状です。

■ 小径深穴加工用ドリルです。(最小径φ0.03)

For drilling precision small deep holes. (smallest diameter φ0.03)

■ 一般鋼材から非鉄、樹脂まで幅広い適用が可能です。

Wide application available covering from steel to non-ferrous and resin.

刃径公差：+0～-0.005

φD Tolerance



型番 CODE NUMBER	径 φD	刃長 ℓ	全長 L	シャンク d	定価 ¥
ADRL-0003	0.03	0.6	38	3	21,670
ADRL-0004	0.04	0.8	38	3	16,340
ADRL-0005	0.05	1.1	38	3	14,300
ADRL-0006	0.06	1.2	38	3	12,800
ADRL-0007	0.07	1.4	38	3	11,300
ADRL-0008	0.08	1.6	38	3	9,800
ADRL-0009	0.09	1.8	38	3	9,300
ADRL-0010	0.1	2.5	38	3	5,940
ADRL-0011	0.11	2.5	38	3	5,500
ADRL-0012	0.12	3	38	3	5,500
ADRL-0013	0.13	3	38	3	5,500
ADRL-0014	0.14	3	38	3	5,500
ADRL-0015	0.15	4	38	3	5,500
ADRL-0016	0.16	4	38	3	5,500
ADRL-0017	0.17	4.5	38	3	5,500
ADRL-0018	0.18	4.5	38	3	5,070
ADRL-0019	0.19	4.5	38	3	5,070
ADRL-0020	0.2	6	38	3	5,070
ADRL-0021	0.21	6	38	3	5,070
ADRL-0022	0.22	6	38	3	5,070
ADRL-0023	0.23	6	38	3	5,070
ADRL-0024	0.24	6	38	3	5,070
ADRL-0025	0.25	7	38	3	5,070
ADRL-0026	0.26	7	38	3	5,070
ADRL-0027	0.27	7	38	3	5,070
ADRL-0028	0.28	7	38	3	5,070

型番 CODE NUMBER	径 φD	刃長 ℓ	全長 L	シャンク d	定価 ¥
ADRL-0029	0.29	7	38	3	5,070
ADRL-0030	0.3	9	45	3	4,640
ADRL-0031	0.31	9	45	3	4,640
ADRL-0032	0.32	9	45	3	4,640
ADRL-0033	0.33	9	45	3	4,640
ADRL-0034	0.34	9	45	3	4,640
ADRL-0035	0.35	10	45	3	4,640
ADRL-0036	0.36	10	45	3	4,640
ADRL-0037	0.37	10	45	3	4,640
ADRL-0038	0.38	10	45	3	4,640
ADRL-0039	0.39	10	45	3	4,640
ADRL-0040	0.4	12	45	3	4,640
ADRL-0041	0.41	12	45	3	4,640
ADRL-0042	0.42	12	45	3	4,640
ADRL-0043	0.43	12	45	3	4,640
ADRL-0044	0.44	12	45	3	4,640
ADRL-0045	0.45	12	45	3	4,640
ADRL-0046	0.46	12	45	3	4,640
ADRL-0047	0.47	12	45	3	4,640
ADRL-0048	0.48	12	45	3	4,640
ADRL-0049	0.49	12	45	3	4,640
ADRL-0050	0.5	12	45	3	4,640
ADRL-0051	0.51	12	45	3	4,640
ADRL-0052	0.52	12	45	3	4,640
ADRL-0053	0.53	12	45	3	4,640
ADRL-0054	0.54	12	45	3	4,640

単位 Unit : mm

型番 CODE NUMBER	径 φD	刃長 ℓ	全長 L	シャンク d	定価 ¥
ADRL-0055	0.55	12	45	3	4,640
ADRL-0056	0.56	12	45	3	4,640
ADRL-0057	0.57	12	45	3	4,640
ADRL-0058	0.58	12	45	3	4,640
ADRL-0059	0.59	12	45	3	4,640
ADRL-0060	0.6	15	45	3	4,640
ADRL-0061	0.61	15	45	3	4,640
ADRL-0062	0.62	15	45	3	4,640
ADRL-0063	0.63	15	45	3	4,640
ADRL-0064	0.64	15	45	3	4,640
ADRL-0065	0.65	15	45	3	4,640
ADRL-0066	0.66	15	45	3	4,640
ADRL-0067	0.67	15	45	3	4,640
ADRL-0068	0.68	15	45	3	4,640
ADRL-0069	0.69	15	45	3	4,640
ADRL-0070	0.7	15	45	3	4,640
ADRL-0071	0.71	15	45	3	4,640
ADRL-0072	0.72	15	45	3	4,640
ADRL-0073	0.73	15	45	3	4,640
ADRL-0074	0.74	15	45	3	4,640
ADRL-0075	0.75	15	45	3	4,640
ADRL-0076	0.76	15	45	3	4,640
ADRL-0077	0.77	15	45	3	4,640
ADRL-0078	0.78	15	45	3	4,640
ADRL-0079	0.79	15	45	3	4,640
ADRL-0080	0.8	15	45	3	4,640
ADRL-0081	0.81	15	45	3	4,640
ADRL-0082	0.82	15	45	3	4,640
ADRL-0083	0.83	15	45	3	4,640
ADRL-0084	0.84	15	45	3	4,640
ADRL-0085	0.85	15	45	3	4,640
ADRL-0086	0.86	15	45	3	4,640
ADRL-0087	0.87	15	45	3	4,640
ADRL-0088	0.88	15	45	3	4,640
ADRL-0089	0.89	15	45	3	4,640
ADRL-0090	0.9	15	45	3	4,640
ADRL-0091	0.91	15	45	3	4,640
ADRL-0092	0.92	15	45	3	4,640
ADRL-0093	0.93	15	45	3	4,640
ADRL-0094	0.94	15	45	3	4,640
ADRL-0095	0.95	15	45	3	4,640
ADRL-0096	0.96	15	45	3	4,640
ADRL-0097	0.97	15	45	3	4,640
ADRL-0098	0.98	15	45	3	4,640

型番 CODE NUMBER	径 φD	刃長 ℓ	全長 L	シャンク d	定価 ¥
ADRL-0099	0.99	15	45	3	4,640
ADRL-0100	1	20	50	3	4,640
ADRL-0101	1.01	20	50	3	4,640
ADRL-0102	1.02	20	50	3	4,640
ADRL-0103	1.03	20	50	3	4,640
ADRL-0104	1.04	20	50	3	4,640
ADRL-0105	1.05	20	50	3	4,640
ADRL-0106	1.06	20	50	3	4,640
ADRL-0107	1.07	20	50	3	4,640
ADRL-0108	1.08	20	50	3	4,640
ADRL-0109	1.09	20	50	3	4,640
ADRL-0110	1.1	20	50	3	4,640
ADRL-0111	1.11	20	50	3	4,640
ADRL-0112	1.12	20	50	3	4,640
ADRL-0113	1.13	20	50	3	4,640
ADRL-0114	1.14	20	50	3	4,640
ADRL-0115	1.15	20	50	3	4,640
ADRL-0116	1.16	20	50	3	4,640
ADRL-0117	1.17	20	50	3	4,640
ADRL-0118	1.18	20	50	3	4,640
ADRL-0119	1.19	20	50	3	4,640
ADRL-0120	1.2	20	50	3	4,640
ADRL-0121	1.21	20	50	3	4,640
ADRL-0122	1.22	20	50	3	4,640
ADRL-0123	1.23	20	50	3	4,640
ADRL-0124	1.24	20	50	3	4,640
ADRL-0125	1.25	20	50	3	4,640
ADRL-0126	1.26	20	50	3	4,640
ADRL-0127	1.27	20	50	3	4,640
ADRL-0128	1.28	20	50	3	4,640
ADRL-0129	1.29	20	50	3	4,640
ADRL-0130	1.3	25	60	3	4,640
ADRL-0131	1.31	25	60	3	4,640
ADRL-0132	1.32	25	60	3	4,640
ADRL-0133	1.33	25	60	3	4,640
ADRL-0134	1.34	25	60	3	4,640
ADRL-0135	1.35	25	60	3	4,640
ADRL-0136	1.36	25	60	3	4,640
ADRL-0137	1.37	25	60	3	4,640
ADRL-0138	1.38	25	60	3	4,640
ADRL-0139	1.39	25	60	3	4,640
ADRL-0140	1.4	25	60	3	4,640
ADRL-0141	1.41	25	60	3	4,640
ADRL-0142	1.42	25	60	3	4,640

Next Page ▶

型番 CODE NUMBER	径 φD	刃長 ℓ	全長 L	シャンク d	定価 ¥
ADRL-0143	1.43	25	60	3	4,640
ADRL-0144	1.44	25	60	3	4,640
ADRL-0145	1.45	25	60	3	4,640
ADRL-0146	1.46	25	60	3	4,640
ADRL-0147	1.47	25	60	3	4,640
ADRL-0148	1.48	25	60	3	4,640
ADRL-0149	1.49	25	60	3	4,640
ADRL-0150	1.5	25	60	3	4,640
ADRL-0151	1.51	25	60	3	4,640
ADRL-0152	1.52	25	60	3	4,640
ADRL-0153	1.53	25	60	3	4,640
ADRL-0154	1.54	25	60	3	4,640
ADRL-0155	1.55	25	60	3	4,640
ADRL-0156	1.56	25	60	3	4,640
ADRL-0157	1.57	25	60	3	4,640
ADRL-0158	1.58	25	60	3	4,640
ADRL-0159	1.59	25	60	3	4,640
ADRL-0160	1.6	32	60	3	5,500
ADRL-0161	1.61	32	60	3	5,500
ADRL-0162	1.62	32	60	3	5,500
ADRL-0163	1.63	32	60	3	5,500
ADRL-0164	1.64	32	60	3	5,500
ADRL-0165	1.65	32	60	3	5,500
ADRL-0166	1.66	32	60	3	5,500
ADRL-0167	1.67	32	60	3	5,500
ADRL-0168	1.68	32	60	3	5,500
ADRL-0169	1.69	32	60	3	5,500
ADRL-0170	1.7	32	60	3	5,500
ADRL-0171	1.71	32	60	3	5,500
ADRL-0172	1.72	32	60	3	5,500
ADRL-0173	1.73	32	60	3	5,500
ADRL-0174	1.74	32	60	3	5,500
ADRL-0175	1.75	32	60	3	5,500
ADRL-0176	1.76	32	60	3	5,500
ADRL-0177	1.77	32	60	3	5,500
ADRL-0178	1.78	32	60	3	5,500
ADRL-0179	1.79	32	60	3	5,500
ADRL-0180	1.8	32	60	3	5,500
ADRL-0181	1.81	32	60	3	5,500
ADRL-0182	1.82	32	60	3	5,500
ADRL-0183	1.83	32	60	3	5,500
ADRL-0184	1.84	32	60	3	5,500
ADRL-0185	1.85	32	60	3	5,500
ADRL-0186	1.86	32	60	3	5,500

型番 CODE NUMBER	径 φD	刃長 ℓ	全長 L	シャンク d	定価 ¥
ADRL-0187	1.87	32	60	3	5,500
ADRL-0188	1.88	32	60	3	5,500
ADRL-0189	1.89	32	60	3	5,500
ADRL-0190	1.9	32	60	3	5,500
ADRL-0191	1.91	32	60	3	5,500
ADRL-0192	1.92	32	60	3	5,500
ADRL-0193	1.93	32	60	3	5,500
ADRL-0194	1.94	32	60	3	5,500
ADRL-0195	1.95	32	60	3	5,500
ADRL-0196	1.96	32	60	3	5,500
ADRL-0197	1.97	32	60	3	5,500
ADRL-0198	1.98	32	60	3	5,500
ADRL-0199	1.99	32	60	3	5,500
ADRL-0200	2	32	60	3	5,500
ADRL-0201	2.01	32	60	3	5,500
ADRL-0202	2.02	32	60	3	5,500
ADRL-0203	2.03	32	60	3	5,500
ADRL-0204	2.04	32	60	3	5,500
ADRL-0205	2.05	32	60	3	5,500
ADRL-0206	2.06	32	60	3	5,500
ADRL-0207	2.07	32	60	3	5,500
ADRL-0208	2.08	32	60	3	5,500
ADRL-0209	2.09	32	60	3	5,500
ADRL-0210	2.1	32	60	3	5,500
ADRL-0211	2.11	32	60	3	5,500
ADRL-0212	2.12	32	60	3	5,500
ADRL-0213	2.13	32	60	3	5,500
ADRL-0214	2.14	32	60	3	5,500
ADRL-0215	2.15	32	60	3	5,500
ADRL-0216	2.16	32	60	3	5,500
ADRL-0217	2.17	32	60	3	5,500
ADRL-0218	2.18	32	60	3	5,500
ADRL-0219	2.19	32	60	3	5,500
ADRL-0220	2.2	32	60	3	5,500
ADRL-0221	2.21	32	60	3	5,500
ADRL-0222	2.22	32	60	3	5,500
ADRL-0223	2.23	32	60	3	5,500
ADRL-0224	2.24	32	60	3	5,500
ADRL-0225	2.25	32	60	3	5,500
ADRL-0226	2.26	32	60	3	5,500
ADRL-0227	2.27	32	60	3	5,500
ADRL-0228	2.28	32	60	3	5,500
ADRL-0229	2.29	32	60	3	5,500
ADRL-0230	2.3	32	60	3	5,500





# ルーマドリル 3.175mm シャンク

Micro Drill, 1/8 inch shank

## ADR31

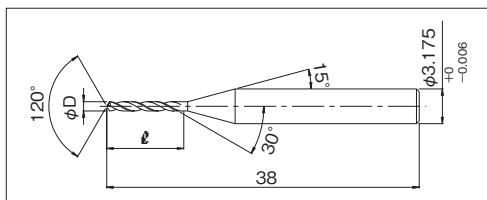

φ0.04は首逃げ2段形状です。

■ 精密・多孔細穴加工用ドリルです。

Best for or drilling precision small holes.

■ 一般鋼材から非鉄、樹脂まで幅広い適用が可能です。

Wide application available covering from steel to non-ferrous and resin.

刃径公差：+0~-0.005

φD Tolerance



単位 Unit : mm

型番 CODE NUMBER	径 φD	刃長 ℓ	全長 L	シャンク d	定価 ¥
ADR31-0004	0.04	0.4	38	3.175	13,340
ADR31-0005	0.05	0.5	38	3.175	10,000
ADR31-0006	0.06	0.6	38	3.175	8,670
ADR31-0007	0.07	0.7	38	3.175	7,670
ADR31-0008	0.08	0.8	38	3.175	7,000
ADR31-0009	0.09	0.9	38	3.175	6,340
ADR31-0010	0.1	1.2	38	3.175	4,670
ADR31-0011	0.11	1.2	38	3.175	4,670
ADR31-0012	0.12	1.4	38	3.175	4,670
ADR31-0013	0.13	1.4	38	3.175	4,670
ADR31-0014	0.14	1.4	38	3.175	4,670
ADR31-0015	0.15	1.8	38	3.175	4,000
ADR31-0016	0.16	1.8	38	3.175	4,170
ADR31-0017	0.17	1.8	38	3.175	4,170
ADR31-0018	0.18	2.1	38	3.175	4,170
ADR31-0019	0.19	2.1	38	3.175	4,170
ADR31-0020	0.2	2.4	38	3.175	3,670
ADR31-0021	0.21	2.4	38	3.175	3,750
ADR31-0022	0.22	2.6	38	3.175	3,750
ADR31-0023	0.23	2.6	38	3.175	3,750
ADR31-0024	0.24	2.6	38	3.175	3,750
ADR31-0025	0.25	3	38	3.175	3,670
ADR31-0026	0.26	3	38	3.175	3,670
ADR31-0027	0.27	3	38	3.175	3,670
ADR31-0028	0.28	3.3	38	3.175	3,670
ADR31-0029	0.29	3.3	38	3.175	3,670

型番 CODE NUMBER	径 φD	刃長 ℓ	全長 L	シャンク d	定価 ¥
ADR31-0030	0.3	5	38	3.175	3,340
ADR31-0031	0.31	5	38	3.175	3,340
ADR31-0032	0.32	5	38	3.175	3,340
ADR31-0033	0.33	5	38	3.175	3,340
ADR31-0034	0.34	5	38	3.175	3,340
ADR31-0035	0.35	5	38	3.175	3,340
ADR31-0036	0.36	5	38	3.175	3,340
ADR31-0037	0.37	5	38	3.175	3,340
ADR31-0038	0.38	5	38	3.175	3,340
ADR31-0039	0.39	5	38	3.175	3,340
ADR31-0040	0.4	6	38	3.175	3,340
ADR31-0041	0.41	6	38	3.175	3,340
ADR31-0042	0.42	6	38	3.175	3,340
ADR31-0043	0.43	6	38	3.175	3,340
ADR31-0044	0.44	6	38	3.175	3,340
ADR31-0045	0.45	6	38	3.175	3,340
ADR31-0046	0.46	6	38	3.175	3,340
ADR31-0047	0.47	6	38	3.175	3,340
ADR31-0048	0.48	6	38	3.175	3,340
ADR31-0049	0.49	6	38	3.175	3,340
ADR31-0050	0.5	6	38	3.175	3,340
ADR31-0051	0.51	6	38	3.175	3,340
ADR31-0052	0.52	6	38	3.175	3,340
ADR31-0053	0.53	6	38	3.175	3,340
ADR31-0054	0.54	6	38	3.175	3,340
ADR31-0055	0.55	6	38	3.175	3,340

単位 Unit : mm

型番 CODE NUMBER	径 φD	刃長 ℓ	全長 L	シャンク d	定価 ¥
ADR31-0056	0.56	6	38	3.175	3,340
ADR31-0057	0.57	6	38	3.175	3,340
ADR31-0058	0.58	6	38	3.175	3,340
ADR31-0059	0.59	6	38	3.175	3,340
ADR31-0060	0.6	7	38	3.175	3,340
ADR31-0061	0.61	7	38	3.175	3,340
ADR31-0062	0.62	7	38	3.175	3,340
ADR31-0063	0.63	7	38	3.175	3,340
ADR31-0064	0.64	7	38	3.175	3,340
ADR31-0065	0.65	7	38	3.175	3,340
ADR31-0066	0.66	7	38	3.175	3,340
ADR31-0067	0.67	7	38	3.175	3,340
ADR31-0068	0.68	7	38	3.175	3,340
ADR31-0069	0.69	7	38	3.175	3,340
ADR31-0070	0.7	8	38	3.175	3,340
ADR31-0071	0.71	8	38	3.175	3,340
ADR31-0072	0.72	8	38	3.175	3,340
ADR31-0073	0.73	8	38	3.175	3,340
ADR31-0074	0.74	8	38	3.175	3,340
ADR31-0075	0.75	8	38	3.175	3,340
ADR31-0076	0.76	8	38	3.175	3,340
ADR31-0077	0.77	8	38	3.175	3,340
ADR31-0078	0.78	8	38	3.175	3,340
ADR31-0079	0.79	8	38	3.175	3,340
ADR31-0080	0.8	8	38	3.175	3,340
ADR31-0081	0.81	8	38	3.175	3,340
ADR31-0082	0.82	8	38	3.175	3,340
ADR31-0083	0.83	8	38	3.175	3,340
ADR31-0084	0.84	8	38	3.175	3,340
ADR31-0085	0.85	8	38	3.175	3,340
ADR31-0086	0.86	8	38	3.175	3,340
ADR31-0087	0.87	8	38	3.175	3,340
ADR31-0088	0.88	8	38	3.175	3,340
ADR31-0089	0.89	8	38	3.175	3,340
ADR31-0090	0.9	8	38	3.175	3,340
ADR31-0091	0.91	8	38	3.175	3,340
ADR31-0092	0.92	8	38	3.175	3,340
ADR31-0093	0.93	8	38	3.175	3,340
ADR31-0094	0.94	8	38	3.175	3,340
ADR31-0095	0.95	8	38	3.175	3,340
ADR31-0096	0.96	8	38	3.175	3,340
ADR31-0097	0.97	8	38	3.175	3,340
ADR31-0098	0.98	8	38	3.175	3,340
ADR31-0099	0.99	8	38	3.175	3,340

型番 CODE NUMBER	径 φD	刃長 ℓ	全長 L	シャンク d	定価 ¥
ADR31-0100	1	10	38	3.175	3,340
ADR31-0101	1.01	10	38	3.175	3,340
ADR31-0102	1.02	10	38	3.175	3,340
ADR31-0103	1.03	10	38	3.175	3,340
ADR31-0104	1.04	10	38	3.175	3,340
ADR31-0105	1.05	10	38	3.175	3,340
ADR31-0106	1.06	10	38	3.175	3,340
ADR31-0107	1.07	10	38	3.175	3,340
ADR31-0108	1.08	10	38	3.175	3,340
ADR31-0109	1.09	10	38	3.175	3,340
ADR31-0110	1.1	10	38	3.175	3,340
ADR31-0111	1.11	10	38	3.175	3,340
ADR31-0112	1.12	10	38	3.175	3,340
ADR31-0113	1.13	10	38	3.175	3,340
ADR31-0114	1.14	10	38	3.175	3,340
ADR31-0115	1.15	10	38	3.175	3,340
ADR31-0116	1.16	10	38	3.175	3,340
ADR31-0117	1.17	10	38	3.175	3,340
ADR31-0118	1.18	10	38	3.175	3,340
ADR31-0119	1.19	10	38	3.175	3,340
ADR31-0120	1.2	10	38	3.175	3,340
ADR31-0121	1.21	10	38	3.175	3,340
ADR31-0122	1.22	10	38	3.175	3,340
ADR31-0123	1.23	10	38	3.175	3,340
ADR31-0124	1.24	10	38	3.175	3,340
ADR31-0125	1.25	10	38	3.175	3,340
ADR31-0126	1.26	10	38	3.175	3,340
ADR31-0127	1.27	10	38	3.175	3,340
ADR31-0128	1.28	10	38	3.175	3,340
ADR31-0129	1.29	10	38	3.175	3,340
ADR31-0130	1.3	10	38	3.175	3,340
ADR31-0131	1.31	10	38	3.175	3,340
ADR31-0132	1.32	10	38	3.175	3,340
ADR31-0133	1.33	10	38	3.175	3,340
ADR31-0134	1.34	10	38	3.175	3,340
ADR31-0135	1.35	10	38	3.175	3,340
ADR31-0136	1.36	10	38	3.175	3,340
ADR31-0137	1.37	10	38	3.175	3,340
ADR31-0138	1.38	10	38	3.175	3,340
ADR31-0139	1.39	10	38	3.175	3,340
ADR31-0140	1.4	10	38	3.175	3,340
ADR31-0141	1.41	10	38	3.175	3,340
ADR31-0142	1.42	10	38	3.175	3,340
ADR31-0143	1.43	10	38	3.175	3,340

Next Page ▶





# ハイスペック ルーマドリル

Super Precision Micro Drill

## ADR-SP

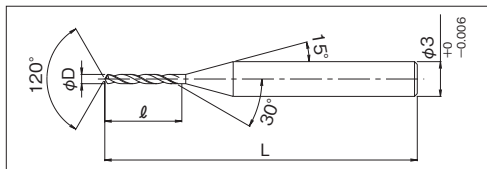

φ0.035~φ0.045は首逃げ2段形状です。

■ ドリル径0.01mmとびサイズの間サイズを標準化。

Drill diameter 0.005mm increment is standardized.

■ 穴精度を左右する振れ精度・リップハイト差を2μ以内に抑えた高仕様・高精度ドリルです。

This super precision drill provides under 2μ tolerance of run-out accuracy and lip height difference.

刃径公差: +0~-0.003

φD Tolerance

振れ精度: 0.002以内

Run out accuracy

リップハイト差: 0.002以下

Lip Height difference



単位 Unit : mm

型番 CODE NUMBER	径 φD	刃長 ℓ	全長 L	シャンク d	定価 ¥
ADR-SP-00035	0.035	0.4	38	3	20,670
ADR-SP-00045	0.045	0.5	38	3	15,000
ADR-SP-00055	0.055	0.6	38	3	12,340
ADR-SP-00065	0.065	0.7	38	3	11,670
ADR-SP-00075	0.075	0.8	38	3	10,670
ADR-SP-00085	0.085	0.9	38	3	9,340
ADR-SP-00095	0.095	1.2	38	3	7,670
ADR-SP-00105	0.105	1.2	38	3	6,670
ADR-SP-00115	0.115	1.4	38	3	6,670
ADR-SP-00125	0.125	1.4	38	3	6,670
ADR-SP-00135	0.135	1.4	38	3	6,670
ADR-SP-00145	0.145	1.8	38	3	6,670
ADR-SP-00155	0.155	1.8	38	3	6,000
ADR-SP-00165	0.165	1.8	38	3	6,000
ADR-SP-00175	0.175	2.1	38	3	6,000
ADR-SP-00185	0.185	2.1	38	3	6,000
ADR-SP-00195	0.195	2.4	38	3	6,000
ADR-SP-00205	0.205	2.4	38	3	5,340
ADR-SP-00215	0.215	2.6	38	3	5,340
ADR-SP-00225	0.225	2.6	38	3	5,340
ADR-SP-00235	0.235	2.6	38	3	5,340
ADR-SP-00245	0.245	3	38	3	5,340
ADR-SP-00255	0.255	3	38	3	5,340
ADR-SP-00265	0.265	3	38	3	5,340

型番 CODE NUMBER	径 φD	刃長 ℓ	全長 L	シャンク d	定価 ¥
ADR-SP-00275	0.275	3.3	38	3	5,340
ADR-SP-00285	0.285	3.3	38	3	5,340
ADR-SP-00295	0.295	5	38	3	5,340
ADR-SP-00305	0.305	5	38	3	4,670
ADR-SP-00315	0.315	5	38	3	4,670
ADR-SP-00325	0.325	5	38	3	4,670
ADR-SP-00335	0.335	5	38	3	4,670
ADR-SP-00345	0.345	5	38	3	4,670
ADR-SP-00355	0.355	5	38	3	4,670
ADR-SP-00365	0.365	5	38	3	4,670
ADR-SP-00375	0.375	5	38	3	4,670
ADR-SP-00385	0.385	5	38	3	4,670
ADR-SP-00395	0.395	6	38	3	4,670
ADR-SP-00405	0.405	6	38	3	4,670
ADR-SP-00415	0.415	6	38	3	4,670
ADR-SP-00425	0.425	6	38	3	4,670
ADR-SP-00435	0.435	6	38	3	4,670
ADR-SP-00445	0.445	6	38	3	4,670
ADR-SP-00455	0.455	6	38	3	4,670
ADR-SP-00465	0.465	6	38	3	4,670
ADR-SP-00475	0.475	6	38	3	4,670
ADR-SP-00485	0.485	6	38	3	4,670
ADR-SP-00495	0.495	6	38	3	4,670
ADR-SP-00505	0.505	6	38	3	4,670

単位 Unit : mm

型番 CODE NUMBER	径 φD	刃長 ℓ	全長 L	シャンク d	定価 ¥
ADR-SP-00515	0.515	6	38	3	4,670
ADR-SP-00525	0.525	6	38	3	4,670
ADR-SP-00535	0.535	6	38	3	4,670
ADR-SP-00545	0.545	6	38	3	4,670
ADR-SP-00555	0.555	6	38	3	4,670
ADR-SP-00565	0.565	6	38	3	4,670
ADR-SP-00575	0.575	6	38	3	4,670
ADR-SP-00585	0.585	6	38	3	4,670
ADR-SP-00595	0.595	7	38	3	4,670
ADR-SP-00605	0.605	7	38	3	4,670
ADR-SP-00615	0.615	7	38	3	4,670
ADR-SP-00625	0.625	7	38	3	4,670
ADR-SP-00635	0.635	7	38	3	4,670
ADR-SP-00645	0.645	7	38	3	4,670
ADR-SP-00655	0.655	7	38	3	4,670
ADR-SP-00665	0.665	7	38	3	4,670
ADR-SP-00675	0.675	7	38	3	4,670
ADR-SP-00685	0.685	7	38	3	4,670
ADR-SP-00695	0.695	8	38	3	4,670
ADR-SP-00705	0.705	8	38	3	4,670
ADR-SP-00715	0.715	8	38	3	4,670
ADR-SP-00725	0.725	8	38	3	4,670
ADR-SP-00735	0.735	8	38	3	4,670
ADR-SP-00745	0.745	8	38	3	4,670
ADR-SP-00755	0.755	8	38	3	4,670
ADR-SP-00765	0.765	8	38	3	4,670
ADR-SP-00775	0.775	8	38	3	4,670
ADR-SP-00785	0.785	8	38	3	4,670
ADR-SP-00795	0.795	8	38	3	4,670
ADR-SP-00805	0.805	8	38	3	4,670
ADR-SP-00815	0.815	8	38	3	4,670
ADR-SP-00825	0.825	8	38	3	4,670
ADR-SP-00835	0.835	8	38	3	4,670
ADR-SP-00845	0.845	8	38	3	4,670
ADR-SP-00855	0.855	8	38	3	4,670
ADR-SP-00865	0.865	8	38	3	4,670
ADR-SP-00875	0.875	8	38	3	4,670
ADR-SP-00885	0.885	8	38	3	4,670
ADR-SP-00895	0.895	8	38	3	4,670
ADR-SP-00905	0.905	8	38	3	4,670
ADR-SP-00915	0.915	8	38	3	4,670
ADR-SP-00925	0.925	8	38	3	4,670
ADR-SP-00935	0.935	8	38	3	4,670
ADR-SP-00945	0.945	8	38	3	4,670

型番 CODE NUMBER	径 φD	刃長 ℓ	全長 L	シャンク d	定価 ¥
ADR-SP-00955	0.955	8	38	3	4,670
ADR-SP-00965	0.965	8	38	3	4,670
ADR-SP-00975	0.975	8	38	3	4,670
ADR-SP-00985	0.985	8	38	3	4,670
ADR-SP-00995	0.995	10	38	3	4,670
ADR-SP-01005	1.005	10	38	3	4,670
ADR-SP-01015	1.015	10	38	3	4,670
ADR-SP-01025	1.025	10	38	3	4,670
ADR-SP-01035	1.035	10	38	3	4,670
ADR-SP-01045	1.045	10	38	3	4,670
ADR-SP-01055	1.055	10	38	3	4,670
ADR-SP-01065	1.065	10	38	3	4,670
ADR-SP-01075	1.075	10	38	3	4,670
ADR-SP-01085	1.085	10	38	3	4,670
ADR-SP-01095	1.095	10	38	3	4,670
ADR-SP-01105	1.105	10	38	3	4,670
ADR-SP-01115	1.115	10	38	3	4,670
ADR-SP-01125	1.125	10	38	3	4,670
ADR-SP-01135	1.135	10	38	3	4,670
ADR-SP-01145	1.145	10	38	3	4,670
ADR-SP-01155	1.155	10	38	3	4,670
ADR-SP-01165	1.165	10	38	3	4,670
ADR-SP-01175	1.175	10	38	3	4,670
ADR-SP-01185	1.185	10	38	3	4,670
ADR-SP-01195	1.195	10	38	3	4,670
ADR-SP-01205	1.205	10	38	3	4,670
ADR-SP-01215	1.215	10	38	3	4,670
ADR-SP-01225	1.225	10	38	3	4,670
ADR-SP-01235	1.235	10	38	3	4,670
ADR-SP-01245	1.245	10	38	3	4,670
ADR-SP-01255	1.255	10	38	3	4,670
ADR-SP-01265	1.265	10	38	3	4,670
ADR-SP-01275	1.275	10	38	3	4,670
ADR-SP-01285	1.285	10	38	3	4,670
ADR-SP-01295	1.295	10	38	3	4,670
ADR-SP-01305	1.305	10	38	3	4,670
ADR-SP-01315	1.315	10	38	3	4,670
ADR-SP-01325	1.325	10	38	3	4,670
ADR-SP-01335	1.335	10	38	3	4,670
ADR-SP-01345	1.345	10	38	3	4,670
ADR-SP-01355	1.355	10	38	3	4,670
ADR-SP-01365	1.365	10	38	3	4,670
ADR-SP-01375	1.375	10	38	3	4,670
ADR-SP-01385	1.385	10	38	3	4,670

Next Page ▶





鋼材細穴加工用 for Steels

## マイクロドリル “NEO-PRO” ショート刃

Micro Drill “NEO-PRO” Series, Short Flute Length

FCSコーティング

## ADRS-SV



■ 鋼材細穴加工用に開発された、安定した長寿命加工を実現するシリーズです。

Stable long-lived machining can be achieved for precision small hole drilling of steels.

■ 軟鋼材から高硬度（HRC50）まで幅広い対応が可能なコーティングドリルです。

Wide drilling application is available from mild steel to hardened steel (HRC50)

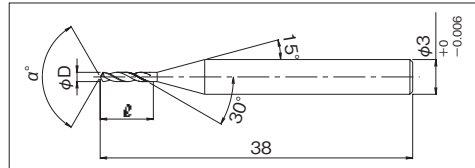
 $\phi D < 1.6: \alpha' = 120^\circ$   $\phi D \geq 1.6: \alpha' = 135^\circ$ 

刃径公差：+0～-0.005  
φ D Tolerance



φD ≥ 1.6



φD ≥ 1.6



単位 Unit : mm

型番 CODE NUMBER	径 φD	刃長 ℓ	全長 L	シャンク d	定価 ¥
ADRS-SV-0010	0.1	0.6	38	3	5,930
ADRS-SV-0011	0.11	0.6	38	3	5,930
ADRS-SV-0012	0.12	0.6	38	3	5,930
ADRS-SV-0013	0.13	0.6	38	3	5,930
ADRS-SV-0014	0.14	0.6	38	3	5,930
ADRS-SV-0015	0.15	0.8	38	3	5,930
ADRS-SV-0016	0.16	0.8	38	3	5,930
ADRS-SV-0017	0.17	0.8	38	3	5,930
ADRS-SV-0018	0.18	1	38	3	5,630
ADRS-SV-0019	0.19	1	38	3	5,630
ADRS-SV-0020	0.2	1	38	3	5,630
ADRS-SV-0021	0.21	1	38	3	5,100
ADRS-SV-0022	0.22	1.2	38	3	5,100
ADRS-SV-0023	0.23	1.2	38	3	5,100
ADRS-SV-0024	0.24	1.2	38	3	5,100
ADRS-SV-0025	0.25	1.5	38	3	5,100
ADRS-SV-0026	0.26	1.5	38	3	5,100
ADRS-SV-0027	0.27	1.5	38	3	5,100
ADRS-SV-0028	0.28	1.5	38	3	5,100
ADRS-SV-0029	0.29	1.5	38	3	5,100
ADRS-SV-0030	0.3	2.5	38	3	5,100
ADRS-SV-0031	0.31	2.5	38	3	4,330

型番 CODE NUMBER	径 φD	刃長 ℓ	全長 L	シャンク d	定価 ¥
ADRS-SV-0032	0.32	2.5	38	3	4,330
ADRS-SV-0033	0.33	2.5	38	3	4,330
ADRS-SV-0034	0.34	2.5	38	3	4,330
ADRS-SV-0035	0.35	2.5	38	3	4,330
ADRS-SV-0036	0.36	2.5	38	3	4,330
ADRS-SV-0037	0.37	2.5	38	3	4,330
ADRS-SV-0038	0.38	2.5	38	3	4,330
ADRS-SV-0039	0.39	2.5	38	3	4,330
ADRS-SV-0040	0.4	3	38	3	4,000
ADRS-SV-0041	0.41	3	38	3	4,330
ADRS-SV-0042	0.42	3	38	3	4,330
ADRS-SV-0043	0.43	3	38	3	4,330
ADRS-SV-0044	0.44	3	38	3	4,330
ADRS-SV-0045	0.45	3	38	3	4,330
ADRS-SV-0046	0.46	3	38	3	4,330
ADRS-SV-0047	0.47	3	38	3	4,330
ADRS-SV-0048	0.48	3	38	3	4,330
ADRS-SV-0049	0.49	3	38	3	4,330
ADRS-SV-0050	0.5	3	38	3	4,000
ADRS-SV-0051	0.51	3	38	3	4,330
ADRS-SV-0052	0.52	3	38	3	4,330
ADRS-SV-0053	0.53	3	38	3	4,330

Next Page ▶

型番 CODE NUMBER	径 φD	刃長 ℓ	全長 L	シャンク d	定価 ¥
ADRS-SV-0054	0.54	3	38	3	4,330
ADRS-SV-0055	0.55	3	38	3	4,330
ADRS-SV-0056	0.56	3	38	3	4,330
ADRS-SV-0057	0.57	3	38	3	4,330
ADRS-SV-0058	0.58	3	38	3	4,330
ADRS-SV-0059	0.59	3	38	3	4,330
ADRS-SV-0060	0.6	3	38	3	4,000
ADRS-SV-0061	0.61	3	38	3	4,330
ADRS-SV-0062	0.62	3	38	3	4,330
ADRS-SV-0063	0.63	3	38	3	4,330
ADRS-SV-0064	0.64	3	38	3	4,330
ADRS-SV-0065	0.65	3	38	3	4,330
ADRS-SV-0066	0.66	3	38	3	4,330
ADRS-SV-0067	0.67	3	38	3	4,330
ADRS-SV-0068	0.68	3	38	3	4,330
ADRS-SV-0069	0.69	3	38	3	4,330
ADRS-SV-0070	0.7	4	38	3	4,000
ADRS-SV-0071	0.71	4	38	3	4,330
ADRS-SV-0072	0.72	4	38	3	4,330
ADRS-SV-0073	0.73	4	38	3	4,330
ADRS-SV-0074	0.74	4	38	3	4,330
ADRS-SV-0075	0.75	4	38	3	4,330
ADRS-SV-0076	0.76	4	38	3	4,330
ADRS-SV-0077	0.77	4	38	3	4,330
ADRS-SV-0078	0.78	4	38	3	4,330
ADRS-SV-0079	0.79	4	38	3	4,330
ADRS-SV-0080	0.8	4	38	3	4,000
ADRS-SV-0081	0.81	4	38	3	4,330
ADRS-SV-0082	0.82	4	38	3	4,330
ADRS-SV-0083	0.83	4	38	3	4,330
ADRS-SV-0084	0.84	4	38	3	4,330
ADRS-SV-0085	0.85	4	38	3	4,330
ADRS-SV-0086	0.86	4	38	3	4,330
ADRS-SV-0087	0.87	4	38	3	4,330
ADRS-SV-0088	0.88	4	38	3	4,330
ADRS-SV-0089	0.89	4	38	3	4,330
ADRS-SV-0090	0.9	4	38	3	4,000
ADRS-SV-0091	0.91	4	38	3	4,330
ADRS-SV-0092	0.92	4	38	3	4,330
ADRS-SV-0093	0.93	4	38	3	4,330
ADRS-SV-0094	0.94	4	38	3	4,330
ADRS-SV-0095	0.95	4	38	3	4,330
ADRS-SV-0096	0.96	4	38	3	4,330
ADRS-SV-0097	0.97	4	38	3	4,330

型番 CODE NUMBER	径 φD	刃長 ℓ	全長 L	シャンク d	定価 ¥
ADRS-SV-0098	0.98	4	38	3	4,330
ADRS-SV-0099	0.99	4	38	3	4,330
ADRS-SV-0100	1	5	38	3	4,000
ADRS-SV-0101	1.01	5	38	3	4,330
ADRS-SV-0102	1.02	5	38	3	4,330
ADRS-SV-0103	1.03	5	38	3	4,330
ADRS-SV-0104	1.04	5	38	3	4,330
ADRS-SV-0105	1.05	5	38	3	4,330
ADRS-SV-0106	1.06	5	38	3	4,330
ADRS-SV-0107	1.07	5	38	3	4,330
ADRS-SV-0108	1.08	5	38	3	4,330
ADRS-SV-0109	1.09	5	38	3	4,330
ADRS-SV-0110	1.1	5	38	3	4,000
ADRS-SV-0111	1.11	5	38	3	4,330
ADRS-SV-0112	1.12	5	38	3	4,330
ADRS-SV-0113	1.13	5	38	3	4,330
ADRS-SV-0114	1.14	5	38	3	4,330
ADRS-SV-0115	1.15	5	38	3	4,330
ADRS-SV-0116	1.16	5	38	3	4,330
ADRS-SV-0117	1.17	5	38	3	4,330
ADRS-SV-0118	1.18	5	38	3	4,330
ADRS-SV-0119	1.19	5	38	3	4,330
ADRS-SV-0120	1.2	5	38	3	4,000
ADRS-SV-0121	1.21	5	38	3	4,330
ADRS-SV-0122	1.22	5	38	3	4,330
ADRS-SV-0123	1.23	5	38	3	4,330
ADRS-SV-0124	1.24	5	38	3	4,330
ADRS-SV-0125	1.25	5	38	3	4,330
ADRS-SV-0126	1.26	5	38	3	4,330
ADRS-SV-0127	1.27	5	38	3	4,330
ADRS-SV-0128	1.28	5	38	3	4,330
ADRS-SV-0129	1.29	5	38	3	4,330
ADRS-SV-0130	1.3	5	38	3	4,000
ADRS-SV-0131	1.31	5	38	3	4,330
ADRS-SV-0132	1.32	5	38	3	4,330
ADRS-SV-0133	1.33	5	38	3	4,330
ADRS-SV-0134	1.34	5	38	3	4,330
ADRS-SV-0135	1.35	5	38	3	4,330
ADRS-SV-0136	1.36	5	38	3	4,330
ADRS-SV-0137	1.37	5	38	3	4,330
ADRS-SV-0138	1.38	5	38	3	4,330
ADRS-SV-0139	1.39	5	38	3	4,330
ADRS-SV-0140	1.4	5	38	3	4,000
ADRS-SV-0141	1.41	5	38	3	4,330

単位 Unit : mm

型番 CODE NUMBER	径 φD	刃長 ℓ	全長 L	シャンク d	定価 ¥
ADRS-SV-0142	1.42	5	38	3	4,330
ADRS-SV-0143	1.43	5	38	3	4,330
ADRS-SV-0144	1.44	5	38	3	4,330
ADRS-SV-0145	1.45	5	38	3	4,330
ADRS-SV-0146	1.46	5	38	3	4,330
ADRS-SV-0147	1.47	5	38	3	4,330
ADRS-SV-0148	1.48	5	38	3	4,330
ADRS-SV-0149	1.49	5	38	3	4,330
ADRS-SV-0150	1.5	5	38	3	4,000
ADRS-SV-0151	1.51	5	38	3	4,330
ADRS-SV-0152	1.52	5	38	3	4,330
ADRS-SV-0153	1.53	5	38	3	4,330
ADRS-SV-0154	1.54	5	38	3	4,330
ADRS-SV-0155	1.55	5	38	3	4,330
ADRS-SV-0156	1.56	5	38	3	4,330
ADRS-SV-0157	1.57	5	38	3	4,330
ADRS-SV-0158	1.58	5	38	3	4,330
ADRS-SV-0159	1.59	5	38	3	4,330
ADRS-SV-0160	1.6	10	38	3	4,000
ADRS-SV-0161	1.61	10	38	3	4,450
ADRS-SV-0162	1.62	10	38	3	4,450
ADRS-SV-0163	1.63	10	38	3	4,450
ADRS-SV-0164	1.64	10	38	3	4,450
ADRS-SV-0165	1.65	10	38	3	4,450
ADRS-SV-0166	1.66	10	38	3	4,450
ADRS-SV-0167	1.67	10	38	3	4,450
ADRS-SV-0168	1.68	10	38	3	4,450
ADRS-SV-0169	1.69	10	38	3	4,450
ADRS-SV-0170	1.7	10	38	3	4,450
ADRS-SV-0171	1.71	10	38	3	4,450
ADRS-SV-0172	1.72	10	38	3	4,450
ADRS-SV-0173	1.73	10	38	3	4,450
ADRS-SV-0174	1.74	10	38	3	4,450
ADRS-SV-0175	1.75	10	38	3	4,450
ADRS-SV-0176	1.76	10	38	3	4,450
ADRS-SV-0177	1.77	10	38	3	4,450
ADRS-SV-0178	1.78	10	38	3	4,450
ADRS-SV-0179	1.79	10	38	3	4,450
ADRS-SV-0180	1.8	10	38	3	4,450
ADRS-SV-0181	1.81	10	38	3	4,450
ADRS-SV-0182	1.82	10	38	3	4,450
ADRS-SV-0183	1.83	10	38	3	4,450
ADRS-SV-0184	1.84	10	38	3	4,450
ADRS-SV-0185	1.85	10	38	3	4,450

型番 CODE NUMBER	径 φD	刃長 ℓ	全長 L	シャンク d	定価 ¥
ADRS-SV-0186	1.86	10	38	3	4,450
ADRS-SV-0187	1.87	10	38	3	4,450
ADRS-SV-0188	1.88	10	38	3	4,450
ADRS-SV-0189	1.89	10	38	3	4,450
ADRS-SV-0190	1.9	10	38	3	4,450
ADRS-SV-0191	1.91	10	38	3	4,450
ADRS-SV-0192	1.92	10	38	3	4,450
ADRS-SV-0193	1.93	10	38	3	4,450
ADRS-SV-0194	1.94	10	38	3	4,450
ADRS-SV-0195	1.95	10	38	3	4,450
ADRS-SV-0196	1.96	10	38	3	4,450
ADRS-SV-0197	1.97	10	38	3	4,450
ADRS-SV-0198	1.98	10	38	3	4,450
ADRS-SV-0199	1.99	10	38	3	4,450
ADRS-SV-0200	2	10	38	3	4,450
ADRS-SV-0201	2.01	10	38	3	4,450
ADRS-SV-0202	2.02	10	38	3	4,450
ADRS-SV-0203	2.03	10	38	3	4,450
ADRS-SV-0204	2.04	10	38	3	4,450
ADRS-SV-0205	2.05	10	38	3	4,450
ADRS-SV-0206	2.06	10	38	3	4,450
ADRS-SV-0207	2.07	10	38	3	4,450
ADRS-SV-0208	2.08	10	38	3	4,450
ADRS-SV-0209	2.09	10	38	3	4,450
ADRS-SV-0210	2.1	10	38	3	4,450
ADRS-SV-0211	2.11	10	38	3	4,450
ADRS-SV-0212	2.12	10	38	3	4,450
ADRS-SV-0213	2.13	10	38	3	4,450
ADRS-SV-0214	2.14	10	38	3	4,450
ADRS-SV-0215	2.15	10	38	3	4,450
ADRS-SV-0216	2.16	10	38	3	4,450
ADRS-SV-0217	2.17	10	38	3	4,450
ADRS-SV-0218	2.18	10	38	3	4,450
ADRS-SV-0219	2.19	10	38	3	4,450
ADRS-SV-0220	2.2	10	38	3	4,700
ADRS-SV-0221	2.21	10	38	3	4,700
ADRS-SV-0222	2.22	10	38	3	4,700
ADRS-SV-0223	2.23	10	38	3	4,700
ADRS-SV-0224	2.24	10	38	3	4,700
ADRS-SV-0225	2.25	10	38	3	4,700
ADRS-SV-0226	2.26	10	38	3	4,700
ADRS-SV-0227	2.27	10	38	3	4,700
ADRS-SV-0228	2.28	10	38	3	4,700
ADRS-SV-0229	2.29	10	38	3	4,700

Next Page ▶



鋼材細穴加工用 for Steels

## マイクロドリル “NEO-PRO” 標準刃長

Micro Drill “NEO-PRO” Series, Regular Flute Length

FCSコーティング

## ADR-SV



■ 鋼材細穴加工用に開発された、安定した長寿命加工を実現するシリーズです。

Stable long-lived machining can be achieved for precision small hole drilling of steels.

■ 軟鋼材から高硬度（HRC50）まで幅広い対応が可能なコーティングドリルです。

Wide drilling application is available from mild steel to hardened steel (HRC50)

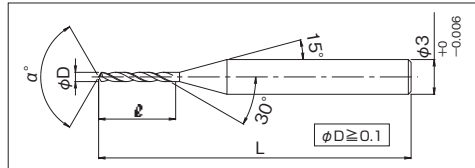
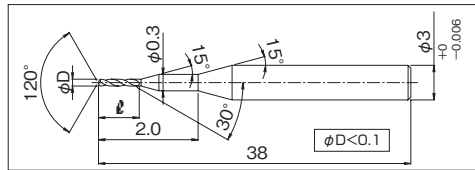
 $\phi D < 1.6: \alpha' = 120^\circ \quad \phi D \ge 1.6: \alpha' = 135^\circ$ 

刃径公差：+0～-0.005  
 $\phi D$  Tolerance

 $\phi D \ge 1.6$  $\phi D \ge 1.6$ 

単位 Unit : mm

型番 CODE NUMBER	径 $\phi D$	刃長 $\ell$	全長 L	シャンク d	定価 ¥
ADR-SV-0003	0.03	0.3	38	3	22,000
ADR-SV-0004	0.04	0.4	38	3	14,830
ADR-SV-0005	0.05	0.5	38	3	12,480
ADR-SV-0006	0.06	0.6	38	3	11,430
ADR-SV-0007	0.07	0.7	38	3	10,380
ADR-SV-0008	0.08	0.8	38	3	8,780
ADR-SV-0009	0.09	0.9	38	3	7,730
ADR-SV-0010	0.1	1.2	38	3	5,930
ADR-SV-0011	0.11	1.2	38	3	5,930
ADR-SV-0012	0.12	1.4	38	3	5,930
ADR-SV-0013	0.13	1.4	38	3	5,930
ADR-SV-0014	0.14	1.4	38	3	5,930
ADR-SV-0015	0.15	1.8	38	3	5,930
ADR-SV-0016	0.16	1.8	38	3	5,930
ADR-SV-0017	0.17	1.8	38	3	5,930
ADR-SV-0018	0.18	2.1	38	3	5,630
ADR-SV-0019	0.19	2.1	38	3	5,630
ADR-SV-0020	0.2	2.4	38	3	5,630
ADR-SV-0021	0.21	2.4	38	3	5,100
ADR-SV-0022	0.22	2.6	38	3	5,100
ADR-SV-0023	0.23	2.6	38	3	5,100
ADR-SV-0024	0.24	2.6	38	3	5,100

型番 CODE NUMBER	径 $\phi D$	刃長 $\ell$	全長 L	シャンク d	定価 ¥
ADR-SV-0025	0.25	3	38	3	5,100
ADR-SV-0026	0.26	3	38	3	5,100
ADR-SV-0027	0.27	3	38	3	5,100
ADR-SV-0028	0.28	3.3	38	3	5,100
ADR-SV-0029	0.29	3.3	38	3	5,100
ADR-SV-0030	0.3	5	38	3	5,100
ADR-SV-0031	0.31	5	38	3	4,330
ADR-SV-0032	0.32	5	38	3	4,330
ADR-SV-0033	0.33	5	38	3	4,330
ADR-SV-0034	0.34	5	38	3	4,330
ADR-SV-0035	0.35	5	38	3	4,330
ADR-SV-0036	0.36	5	38	3	4,330
ADR-SV-0037	0.37	5	38	3	4,330
ADR-SV-0038	0.38	5	38	3	4,330
ADR-SV-0039	0.39	5	38	3	4,330
ADR-SV-0040	0.4	6	38	3	4,000
ADR-SV-0041	0.41	6	38	3	4,330
ADR-SV-0042	0.42	6	38	3	4,330
ADR-SV-0043	0.43	6	38	3	4,330
ADR-SV-0044	0.44	6	38	3	4,330
ADR-SV-0045	0.45	6	38	3	4,330
ADR-SV-0046	0.46	6	38	3	4,330

Next Page ▶

型番 CODE NUMBER	径 φD	刃長 ℓ	全長 L	シャンク d	定価 ¥
ADR-SV-0047	0.47	6	38	3	4,330
ADR-SV-0048	0.48	6	38	3	4,330
ADR-SV-0049	0.49	6	38	3	4,330
ADR-SV-0050	0.5	6	38	3	4,000
ADR-SV-0051	0.51	6	38	3	4,330
ADR-SV-0052	0.52	6	38	3	4,330
ADR-SV-0053	0.53	6	38	3	4,330
ADR-SV-0054	0.54	6	38	3	4,330
ADR-SV-0055	0.55	6	38	3	4,330
ADR-SV-0056	0.56	6	38	3	4,330
ADR-SV-0057	0.57	6	38	3	4,330
ADR-SV-0058	0.58	6	38	3	4,330
ADR-SV-0059	0.59	6	38	3	4,330
ADR-SV-0060	0.6	7	38	3	4,000
ADR-SV-0061	0.61	7	38	3	4,330
ADR-SV-0062	0.62	7	38	3	4,330
ADR-SV-0063	0.63	7	38	3	4,330
ADR-SV-0064	0.64	7	38	3	4,330
ADR-SV-0065	0.65	7	38	3	4,330
ADR-SV-0066	0.66	7	38	3	4,330
ADR-SV-0067	0.67	7	38	3	4,330
ADR-SV-0068	0.68	7	38	3	4,330
ADR-SV-0069	0.69	7	38	3	4,330
ADR-SV-0070	0.7	8	38	3	4,000
ADR-SV-0071	0.71	8	38	3	4,330
ADR-SV-0072	0.72	8	38	3	4,330
ADR-SV-0073	0.73	8	38	3	4,330
ADR-SV-0074	0.74	8	38	3	4,330
ADR-SV-0075	0.75	8	38	3	4,330
ADR-SV-0076	0.76	8	38	3	4,330
ADR-SV-0077	0.77	8	38	3	4,330
ADR-SV-0078	0.78	8	38	3	4,330
ADR-SV-0079	0.79	8	38	3	4,330
ADR-SV-0080	0.8	8	38	3	4,000
ADR-SV-0081	0.81	8	38	3	4,330
ADR-SV-0082	0.82	8	38	3	4,330
ADR-SV-0083	0.83	8	38	3	4,330
ADR-SV-0084	0.84	8	38	3	4,330
ADR-SV-0085	0.85	8	38	3	4,330
ADR-SV-0086	0.86	8	38	3	4,330
ADR-SV-0087	0.87	8	38	3	4,330
ADR-SV-0088	0.88	8	38	3	4,330
ADR-SV-0089	0.89	8	38	3	4,330
ADR-SV-0090	0.9	8	38	3	4,000

型番 CODE NUMBER	径 φD	刃長 ℓ	全長 L	シャンク d	定価 ¥
ADR-SV-0091	0.91	8	38	3	4,330
ADR-SV-0092	0.92	8	38	3	4,330
ADR-SV-0093	0.93	8	38	3	4,330
ADR-SV-0094	0.94	8	38	3	4,330
ADR-SV-0095	0.95	8	38	3	4,330
ADR-SV-0096	0.96	8	38	3	4,330
ADR-SV-0097	0.97	8	38	3	4,330
ADR-SV-0098	0.98	8	38	3	4,330
ADR-SV-0099	0.99	8	38	3	4,330
ADR-SV-0100	1	10	38	3	4,000
ADR-SV-0101	1.01	10	38	3	4,330
ADR-SV-0102	1.02	10	38	3	4,330
ADR-SV-0103	1.03	10	38	3	4,330
ADR-SV-0104	1.04	10	38	3	4,330
ADR-SV-0105	1.05	10	38	3	4,330
ADR-SV-0106	1.06	10	38	3	4,330
ADR-SV-0107	1.07	10	38	3	4,330
ADR-SV-0108	1.08	10	38	3	4,330
ADR-SV-0109	1.09	10	38	3	4,330
ADR-SV-0110	1.1	10	38	3	4,000
ADR-SV-0111	1.11	10	38	3	4,330
ADR-SV-0112	1.12	10	38	3	4,330
ADR-SV-0113	1.13	10	38	3	4,330
ADR-SV-0114	1.14	10	38	3	4,330
ADR-SV-0115	1.15	10	38	3	4,330
ADR-SV-0116	1.16	10	38	3	4,330
ADR-SV-0117	1.17	10	38	3	4,330
ADR-SV-0118	1.18	10	38	3	4,330
ADR-SV-0119	1.19	10	38	3	4,330
ADR-SV-0120	1.2	10	38	3	4,000
ADR-SV-0121	1.21	10	38	3	4,330
ADR-SV-0122	1.22	10	38	3	4,330
ADR-SV-0123	1.23	10	38	3	4,330
ADR-SV-0124	1.24	10	38	3	4,330
ADR-SV-0125	1.25	10	38	3	4,330
ADR-SV-0126	1.26	10	38	3	4,330
ADR-SV-0127	1.27	10	38	3	4,330
ADR-SV-0128	1.28	10	38	3	4,330
ADR-SV-0129	1.29	10	38	3	4,330
ADR-SV-0130	1.3	10	38	3	4,000
ADR-SV-0131	1.31	10	38	3	4,330
ADR-SV-0132	1.32	10	38	3	4,330
ADR-SV-0133	1.33	10	38	3	4,330
ADR-SV-0134	1.34	10	38	3	4,330

単位 Unit : mm

型番 CODE NUMBER	径 φD	刃長 ℓ	全長 L	シャンク d	定価 ¥
ADR-SV-0135	1.35	10	38	3	4,330
ADR-SV-0136	1.36	10	38	3	4,330
ADR-SV-0137	1.37	10	38	3	4,330
ADR-SV-0138	1.38	10	38	3	4,330
ADR-SV-0139	1.39	10	38	3	4,330
ADR-SV-0140	1.4	10	38	3	4,000
ADR-SV-0141	1.41	10	38	3	4,330
ADR-SV-0142	1.42	10	38	3	4,330
ADR-SV-0143	1.43	10	38	3	4,330
ADR-SV-0144	1.44	10	38	3	4,330
ADR-SV-0145	1.45	10	38	3	4,330
ADR-SV-0146	1.46	10	38	3	4,330
ADR-SV-0147	1.47	10	38	3	4,330
ADR-SV-0148	1.48	10	38	3	4,330
ADR-SV-0149	1.49	10	38	3	4,330
ADR-SV-0150	1.5	10	38	3	4,000
ADR-SV-0151	1.51	10	38	3	4,330
ADR-SV-0152	1.52	10	38	3	4,330
ADR-SV-0153	1.53	10	38	3	4,330
ADR-SV-0154	1.54	10	38	3	4,330
ADR-SV-0155	1.55	10	38	3	4,330
ADR-SV-0156	1.56	10	38	3	4,330
ADR-SV-0157	1.57	10	38	3	4,330
ADR-SV-0158	1.58	10	38	3	4,330
ADR-SV-0159	1.59	10	38	3	4,330
ADR-SV-0160	1.6	16	45	3	4,000
ADR-SV-0161	1.61	16	45	3	4,450
ADR-SV-0162	1.62	16	45	3	4,450
ADR-SV-0163	1.63	16	45	3	4,450
ADR-SV-0164	1.64	16	45	3	4,450
ADR-SV-0165	1.65	16	45	3	4,450
ADR-SV-0166	1.66	16	45	3	4,450
ADR-SV-0167	1.67	16	45	3	4,450
ADR-SV-0168	1.68	16	45	3	4,450
ADR-SV-0169	1.69	16	45	3	4,450
ADR-SV-0170	1.7	16	45	3	4,450
ADR-SV-0171	1.71	16	45	3	4,450
ADR-SV-0172	1.72	16	45	3	4,450
ADR-SV-0173	1.73	16	45	3	4,450
ADR-SV-0174	1.74	16	45	3	4,450
ADR-SV-0175	1.75	16	45	3	4,450
ADR-SV-0176	1.76	16	45	3	4,450
ADR-SV-0177	1.77	16	45	3	4,450
ADR-SV-0178	1.78	16	45	3	4,450

型番 CODE NUMBER	径 φD	刃長 ℓ	全長 L	シャンク d	定価 ¥
ADR-SV-0179	1.79	16	45	3	4,450
ADR-SV-0180	1.8	16	45	3	4,450
ADR-SV-0181	1.81	16	45	3	4,450
ADR-SV-0182	1.82	16	45	3	4,450
ADR-SV-0183	1.83	16	45	3	4,450
ADR-SV-0184	1.84	16	45	3	4,450
ADR-SV-0185	1.85	16	45	3	4,450
ADR-SV-0186	1.86	16	45	3	4,450
ADR-SV-0187	1.87	16	45	3	4,450
ADR-SV-0188	1.88	16	45	3	4,450
ADR-SV-0189	1.89	16	45	3	4,450
ADR-SV-0190	1.9	16	45	3	4,450
ADR-SV-0191	1.91	16	45	3	4,450
ADR-SV-0192	1.92	16	45	3	4,450
ADR-SV-0193	1.93	16	45	3	4,450
ADR-SV-0194	1.94	16	45	3	4,450
ADR-SV-0195	1.95	16	45	3	4,450
ADR-SV-0196	1.96	16	45	3	4,450
ADR-SV-0197	1.97	16	45	3	4,450
ADR-SV-0198	1.98	16	45	3	4,450
ADR-SV-0199	1.99	16	45	3	4,450
ADR-SV-0200	2	22	50	3	4,450
ADR-SV-0201	2.01	22	50	3	4,450
ADR-SV-0202	2.02	22	50	3	4,450
ADR-SV-0203	2.03	22	50	3	4,450
ADR-SV-0204	2.04	22	50	3	4,450
ADR-SV-0205	2.05	22	50	3	4,450
ADR-SV-0206	2.06	22	50	3	4,450
ADR-SV-0207	2.07	22	50	3	4,450
ADR-SV-0208	2.08	22	50	3	4,450
ADR-SV-0209	2.09	22	50	3	4,450
ADR-SV-0210	2.1	22	50	3	4,450
ADR-SV-0211	2.11	22	50	3	4,450
ADR-SV-0212	2.12	22	50	3	4,450
ADR-SV-0213	2.13	22	50	3	4,450
ADR-SV-0214	2.14	22	50	3	4,450
ADR-SV-0215	2.15	22	50	3	4,450
ADR-SV-0216	2.16	22	50	3	4,450
ADR-SV-0217	2.17	22	50	3	4,450
ADR-SV-0218	2.18	22	50	3	4,450
ADR-SV-0219	2.19	22	50	3	4,450
ADR-SV-0220	2.2	22	50	3	4,700
ADR-SV-0221	2.21	22	50	3	4,700
ADR-SV-0222	2.22	22	50	3	4,700

Next Page ▶

単位 Unit : mm

型番 CODE NUMBER	径 φD	刃長 ℓ	全長 L	シャンク d	定価 ¥
ADR-SV-0223	2.23	22	50	3	4,700
ADR-SV-0224	2.24	22	50	3	4,700
ADR-SV-0225	2.25	22	50	3	4,700
ADR-SV-0226	2.26	22	50	3	4,700
ADR-SV-0227	2.27	22	50	3	4,700
ADR-SV-0228	2.28	22	50	3	4,700
ADR-SV-0229	2.29	22	50	3	4,700
ADR-SV-0230	2.3	22	50	3	4,700
ADR-SV-0231	2.31	22	50	3	4,700
ADR-SV-0232	2.32	22	50	3	4,700
ADR-SV-0233	2.33	22	50	3	4,700
ADR-SV-0234	2.34	22	50	3	4,700
ADR-SV-0235	2.35	22	50	3	4,700
ADR-SV-0236	2.36	22	50	3	4,700
ADR-SV-0237	2.37	22	50	3	4,700
ADR-SV-0238	2.38	22	50	3	4,700
ADR-SV-0239	2.39	22	50	3	4,700
ADR-SV-0240	2.4	22	50	3	4,700
ADR-SV-0241	2.41	22	50	3	4,700
ADR-SV-0242	2.42	22	50	3	4,700
ADR-SV-0243	2.43	22	50	3	4,700
ADR-SV-0244	2.44	22	50	3	4,700
ADR-SV-0245	2.45	22	50	3	4,700
ADR-SV-0246	2.46	22	50	3	4,700
ADR-SV-0247	2.47	22	50	3	4,700
ADR-SV-0248	2.48	22	50	3	4,700
ADR-SV-0249	2.49	22	50	3	4,700
ADR-SV-0250	2.5	22	50	3	4,700
ADR-SV-0251	2.51	22	50	3	4,700
ADR-SV-0252	2.52	22	50	3	4,700
ADR-SV-0253	2.53	22	50	3	4,700
ADR-SV-0254	2.54	22	50	3	4,700
ADR-SV-0255	2.55	22	50	3	4,700
ADR-SV-0256	2.56	22	50	3	4,700
ADR-SV-0257	2.57	22	50	3	4,700
ADR-SV-0258	2.58	22	50	3	4,700
ADR-SV-0259	2.59	22	50	3	4,700
ADR-SV-0260	2.6	22	50	3	4,700
ADR-SV-0261	2.61	22	50	3	4,700
ADR-SV-0262	2.62	22	50	3	4,700
ADR-SV-0263	2.63	22	50	3	4,700
ADR-SV-0264	2.64	22	50	3	4,700
ADR-SV-0265	2.65	22	50	3	4,700
ADR-SV-0266	2.66	22	50	3	4,700

型番 CODE NUMBER	径 φD	刃長 ℓ	全長 L	シャンク d	定価 ¥
ADR-SV-0267	2.67	22	50	3	4,700
ADR-SV-0268	2.68	22	50	3	4,700
ADR-SV-0269	2.69	22	50	3	4,700
ADR-SV-0270	2.7	25	50	3	4,730
ADR-SV-0271	2.71	25	50	3	4,730
ADR-SV-0272	2.72	25	50	3	4,730
ADR-SV-0273	2.73	25	50	3	4,730
ADR-SV-0274	2.74	25	50	3	4,730
ADR-SV-0275	2.75	25	50	3	4,730
ADR-SV-0276	2.76	25	50	3	4,730
ADR-SV-0277	2.77	25	50	3	4,730
ADR-SV-0278	2.78	25	50	3	4,730
ADR-SV-0279	2.79	25	50	3	4,730
ADR-SV-0280	2.8	25	50	3	4,730
ADR-SV-0281	2.81	25	50	3	4,730
ADR-SV-0282	2.82	25	50	3	4,730
ADR-SV-0283	2.83	25	50	3	4,730
ADR-SV-0284	2.84	25	50	3	4,730
ADR-SV-0285	2.85	25	50	3	4,730
ADR-SV-0286	2.86	25	50	3	4,730
ADR-SV-0287	2.87	25	50	3	4,730
ADR-SV-0288	2.88	25	50	3	4,730
ADR-SV-0289	2.89	25	50	3	4,730
ADR-SV-0290	2.9	25	50	3	4,730
ADR-SV-0291	2.91	25	50	3	4,730
ADR-SV-0292	2.92	25	50	3	4,730
ADR-SV-0293	2.93	25	50	3	4,730
ADR-SV-0294	2.94	25	50	3	4,730
ADR-SV-0295	2.95	25	50	3	4,730
ADR-SV-0296	2.96	25	50	3	4,730
ADR-SV-0297	2.97	25	50	3	4,730
ADR-SV-0298	2.98	25	50	3	4,730
ADR-SV-0299	2.99	25	50	3	4,730
ADR-SV-0300	3	25	50	3	4,730

ルーター用  
Micro Drill



鋼材細穴加工用 for Steels

## マイクロドリル “NEO-PRO” セミロング刃

Micro Drill “NEO-PRO” Series, Semi Long Flute Length

FCSコーティング

## ADRSL-SV



■ 鋼材細穴加工用に開発された、安定した長寿命加工を実現するシリーズです。

Stable long-lived machining can be achieved for precision small hole drilling of steels.

■ 軟鋼材から高硬度（HRC50）まで幅広い対応が可能なコーティングドリルです。

Wide drilling application is available from mild steel to hardened steel (HRC50)

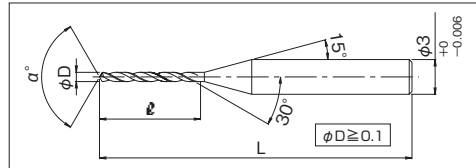

$\phi D < 1.6: \alpha = 120^\circ$   $\phi D \geq 1.6: \alpha = 135^\circ$

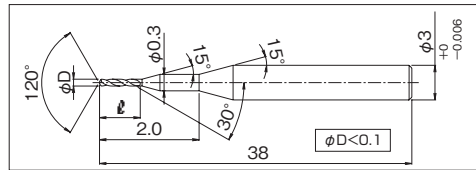

刃径公差：+0～-0.005  
 $\phi D$  Tolerance



単位 Unit : mm

型番 CODE NUMBER	径 $\phi D$	刃長 $\ell$	全長 L	シャンク d	定価 ¥
ADRSL-SV-0003	0.03	0.5	38	3	22,900
ADRSL-SV-0004	0.04	0.6	38	3	16,110
ADRSL-SV-0005	0.05	0.8	38	3	13,810
ADRSL-SV-0006	0.06	0.8	38	3	12,170
ADRSL-SV-0007	0.07	1.1	38	3	11,190
ADRSL-SV-0008	0.08	1.2	38	3	9,580
ADRSL-SV-0009	0.09	1.2	38	3	8,450
ADRSL-SV-0010	0.1	1.9	38	3	6,250
ADRSL-SV-0011	0.11	1.9	38	3	6,100
ADRSL-SV-0012	0.12	2.2	38	3	6,100
ADRSL-SV-0013	0.13	2.2	38	3	6,100
ADRSL-SV-0014	0.14	2.2	38	3	6,100
ADRSL-SV-0015	0.15	2.9	38	3	6,100
ADRSL-SV-0016	0.16	2.9	38	3	6,100
ADRSL-SV-0017	0.17	3.2	38	3	6,100
ADRSL-SV-0018	0.18	3.3	38	3	5,770
ADRSL-SV-0019	0.19	3.3	38	3	5,770
ADRSL-SV-0020	0.2	4	38	3	5,770
ADRSL-SV-0021	0.21	4	38	3	5,360
ADRSL-SV-0022	0.22	4.3	38	3	5,360
ADRSL-SV-0023	0.23	4.3	38	3	5,360
ADRSL-SV-0024	0.24	4.3	38	3	5,360

型番 CODE NUMBER	径 $\phi D$	刃長 $\ell$	全長 L	シャンク d	定価 ¥
ADRSL-SV-0025	0.25	5	38	3	5,360
ADRSL-SV-0026	0.26	5	38	3	5,360
ADRSL-SV-0027	0.27	5	38	3	5,360
ADRSL-SV-0028	0.28	5.2	38	3	5,360
ADRSL-SV-0029	0.29	5.2	38	3	5,360
ADRSL-SV-0030	0.3	7	38	3	5,220
ADRSL-SV-0031	0.31	7	38	3	4,820
ADRSL-SV-0032	0.32	7	38	3	4,820
ADRSL-SV-0033	0.33	7	38	3	4,820
ADRSL-SV-0034	0.34	7	38	3	4,820
ADRSL-SV-0035	0.35	7	38	3	4,820
ADRSL-SV-0036	0.36	7	38	3	4,820
ADRSL-SV-0037	0.37	7	38	3	4,820
ADRSL-SV-0038	0.38	7	38	3	4,820
ADRSL-SV-0039	0.39	7	38	3	4,820
ADRSL-SV-0040	0.4	9	38	3	4,690
ADRSL-SV-0041	0.41	9	38	3	4,820
ADRSL-SV-0042	0.42	9	38	3	4,820
ADRSL-SV-0043	0.43	9	38	3	4,820
ADRSL-SV-0044	0.44	9	38	3	4,820
ADRSL-SV-0045	0.45	9	38	3	4,820
ADRSL-SV-0046	0.46	9	38	3	4,820

Next Page ▶

ADRSL-SV マイクロドリル “NEO-PRO” セミロング刃 FCSコーティング

単位 Unit : mm

型番 CODE NUMBER	径 φD	刃長 ℓ	全長 L	シャンク d	定価 ¥
ADRSL-SV-0047	0.47	9	38	3	4,820
ADRSL-SV-0048	0.48	9	38	3	4,820
ADRSL-SV-0049	0.49	9	38	3	4,820
ADRSL-SV-0050	0.5	9	38	3	4,690
ADRSL-SV-0051	0.51	9	38	3	4,820
ADRSL-SV-0052	0.52	9	38	3	4,820
ADRSL-SV-0053	0.53	9	38	3	4,820
ADRSL-SV-0054	0.54	9	38	3	4,820
ADRSL-SV-0055	0.55	9	38	3	4,820
ADRSL-SV-0056	0.56	9	38	3	4,820
ADRSL-SV-0057	0.57	9	38	3	4,820
ADRSL-SV-0058	0.58	9	38	3	4,820
ADRSL-SV-0059	0.59	9	38	3	4,820
ADRSL-SV-0060	0.6	11	38	3	4,690
ADRSL-SV-0061	0.61	11	38	3	4,820
ADRSL-SV-0062	0.62	11	38	3	4,820
ADRSL-SV-0063	0.63	11	38	3	4,820
ADRSL-SV-0064	0.64	11	38	3	4,820
ADRSL-SV-0065	0.65	11	38	3	4,820
ADRSL-SV-0066	0.66	11	38	3	4,820
ADRSL-SV-0067	0.67	11	38	3	4,820
ADRSL-SV-0068	0.68	11	38	3	4,820
ADRSL-SV-0069	0.69	11	38	3	4,820
ADRSL-SV-0070	0.7	11	38	3	4,690
ADRSL-SV-0071	0.71	11	38	3	4,820
ADRSL-SV-0072	0.72	11	38	3	4,820
ADRSL-SV-0073	0.73	11	38	3	4,820
ADRSL-SV-0074	0.74	11	38	3	4,820
ADRSL-SV-0075	0.75	11	38	3	4,820
ADRSL-SV-0076	0.76	11	38	3	4,820
ADRSL-SV-0077	0.77	11	38	3	4,820
ADRSL-SV-0078	0.78	11	38	3	4,820
ADRSL-SV-0079	0.79	11	38	3	4,820
ADRSL-SV-0080	0.8	11	38	3	4,690
ADRSL-SV-0081	0.81	11	38	3	4,820
ADRSL-SV-0082	0.82	11	38	3	4,820
ADRSL-SV-0083	0.83	11	38	3	4,820
ADRSL-SV-0084	0.84	11	38	3	4,820
ADRSL-SV-0085	0.85	11	38	3	4,820
ADRSL-SV-0086	0.86	11	38	3	4,820
ADRSL-SV-0087	0.87	11	38	3	4,820
ADRSL-SV-0088	0.88	11	38	3	4,820
ADRSL-SV-0089	0.89	11	38	3	4,820
ADRSL-SV-0090	0.9	11	38	3	4,690

型番 CODE NUMBER	径 φD	刃長 ℓ	全長 L	シャンク d	定価 ¥
ADRSL-SV-0091	0.91	11	38	3	4,820
ADRSL-SV-0092	0.92	11	38	3	4,820
ADRSL-SV-0093	0.93	11	38	3	4,820
ADRSL-SV-0094	0.94	11	38	3	4,820
ADRSL-SV-0095	0.95	11	38	3	4,820
ADRSL-SV-0096	0.96	11	38	3	4,820
ADRSL-SV-0097	0.97	11	38	3	4,820
ADRSL-SV-0098	0.98	11	38	3	4,820
ADRSL-SV-0099	0.99	11	38	3	4,820
ADRSL-SV-0100	1	15	45	3	4,690
ADRSL-SV-0105	1.05	15	45	3	4,820
ADRSL-SV-0110	1.1	15	45	3	4,690
ADRSL-SV-0115	1.15	15	45	3	4,820
ADRSL-SV-0120	1.2	15	45	3	4,690
ADRSL-SV-0125	1.25	15	45	3	4,820
ADRSL-SV-0130	1.3	18	45	3	4,690
ADRSL-SV-0135	1.35	18	45	3	4,820
ADRSL-SV-0140	1.4	18	45	3	4,690
ADRSL-SV-0145	1.45	18	45	3	4,820
ADRSL-SV-0150	1.5	18	45	3	4,690
ADRSL-SV-0155	1.55	18	45	3	4,820
ADRSL-SV-0160	1.6	27	60	3	5,470
ADRSL-SV-0165	1.65	27	60	3	5,470
ADRSL-SV-0170	1.7	27	60	3	5,470
ADRSL-SV-0175	1.75	27	60	3	5,470
ADRSL-SV-0180	1.8	27	60	3	5,470
ADRSL-SV-0185	1.85	27	60	3	5,470
ADRSL-SV-0190	1.9	27	60	3	5,470
ADRSL-SV-0195	1.95	27	60	3	5,470
ADRSL-SV-0200	2	27	60	3	5,470
ADRSL-SV-0250	2.5	27	60	3	5,470
ADRSL-SV-0300	3	33	60	3	5,470

Micro Drill  
ルーペ加工用

鋼材細穴加工用 for Steels

## マイクロドリル “NEO-PRO” ロング刃

Micro Drill “NEO-PRO” Series, Long Flute Length

FCSコーティング

## ADRL-SV



■ 鋼材細穴加工用に開発された、安定した長寿命加工を実現するシリーズです。

Stable long-lived machining can be achieved for precision small hole drilling of steels.

■ 軟鋼材から高硬度（HRC50）まで幅広い対応が可能なコーティングドリルです。

Wide drilling application is available from mild steel to hardened steel (HRC50)

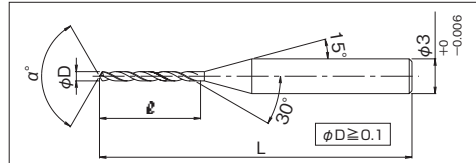
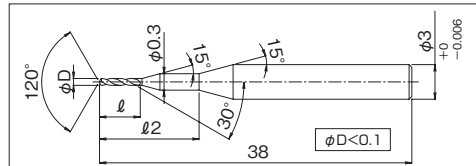
 $\phi D < 1.6: \alpha = 120^\circ \quad \phi D \geq 1.6: \alpha = 135^\circ$ 

 $l \geq 2.0 \quad \phi D = \phi 0.03 \sim \phi 0.04 \quad l \geq 3.0 \quad \phi D = \phi 0.05 \sim \phi 0.09$ 

刃径公差：+0～-0.005  
 $\phi D$  Tolerance



単位 Unit : mm

型番 CODE NUMBER	径 $\phi D$	刃長 $l$	全長 $L$	シャンク $d$	定価 ¥
ADRL-SV-0003	0.03	0.6	38	3	23,830
ADRL-SV-0004	0.04	0.8	38	3	17,970
ADRL-SV-0005	0.05	1.1	38	3	15,730
ADRL-SV-0006	0.06	1.2	38	3	14,080
ADRL-SV-0007	0.07	1.4	38	3	12,430
ADRL-SV-0008	0.08	1.6	38	3	10,780
ADRL-SV-0009	0.09	1.8	38	3	10,230
ADRL-SV-0010	0.1	2.5	38	3	6,820
ADRL-SV-0011	0.11	2.5	38	3	6,330
ADRL-SV-0012	0.12	3	38	3	6,330
ADRL-SV-0013	0.13	3	38	3	6,330
ADRL-SV-0014	0.14	3	38	3	6,330
ADRL-SV-0015	0.15	4	38	3	6,330
ADRL-SV-0016	0.16	4	38	3	6,330
ADRL-SV-0017	0.17	4.5	38	3	6,330
ADRL-SV-0018	0.18	4.5	38	3	5,830
ADRL-SV-0019	0.19	4.5	38	3	5,830
ADRL-SV-0020	0.2	6	38	3	5,830
ADRL-SV-0021	0.21	6	38	3	5,830
ADRL-SV-0022	0.22	6	38	3	5,830
ADRL-SV-0023	0.23	6	38	3	5,830
ADRL-SV-0024	0.24	6	38	3	5,830

型番 CODE NUMBER	径 $\phi D$	刃長 $l$	全長 $L$	シャンク $d$	定価 ¥
ADRL-SV-0025	0.25	7	38	3	5,830
ADRL-SV-0026	0.26	7	38	3	5,830
ADRL-SV-0027	0.27	7	38	3	5,830
ADRL-SV-0028	0.28	7	38	3	5,830
ADRL-SV-0029	0.29	7	38	3	5,830
ADRL-SV-0030	0.3	9	45	3	5,330
ADRL-SV-0031	0.31	9	45	3	5,330
ADRL-SV-0032	0.32	9	45	3	5,330
ADRL-SV-0033	0.33	9	45	3	5,330
ADRL-SV-0034	0.34	9	45	3	5,330
ADRL-SV-0035	0.35	10	45	3	5,330
ADRL-SV-0036	0.36	10	45	3	5,330
ADRL-SV-0037	0.37	10	45	3	5,330
ADRL-SV-0038	0.38	10	45	3	5,330
ADRL-SV-0039	0.39	10	45	3	5,330
ADRL-SV-0040	0.4	12	45	3	5,330
ADRL-SV-0041	0.41	12	45	3	5,330
ADRL-SV-0042	0.42	12	45	3	5,330
ADRL-SV-0043	0.43	12	45	3	5,330
ADRL-SV-0044	0.44	12	45	3	5,330
ADRL-SV-0045	0.45	12	45	3	5,330
ADRL-SV-0046	0.46	12	45	3	5,330

Next Page ▶

# ADRL-SV マイクロドリル “NEO-PRO” ロング刃 FCSCコーティング

単位 Unit : mm

型番 CODE NUMBER	径 φD	刃長 ℓ	全長 L	シャンク d	定価 ¥
ADRL-SV-0047	0.47	12	45	3	5,330
ADRL-SV-0048	0.48	12	45	3	5,330
ADRL-SV-0049	0.49	12	45	3	5,330
ADRL-SV-0050	0.5	12	45	3	5,330
ADRL-SV-0051	0.51	12	45	3	5,330
ADRL-SV-0052	0.52	12	45	3	5,330
ADRL-SV-0053	0.53	12	45	3	5,330
ADRL-SV-0054	0.54	12	45	3	5,330
ADRL-SV-0055	0.55	12	45	3	5,330
ADRL-SV-0056	0.56	12	45	3	5,330
ADRL-SV-0057	0.57	12	45	3	5,330
ADRL-SV-0058	0.58	12	45	3	5,330
ADRL-SV-0059	0.59	12	45	3	5,330
ADRL-SV-0060	0.6	15	45	3	5,330
ADRL-SV-0061	0.61	15	45	3	5,330
ADRL-SV-0062	0.62	15	45	3	5,330
ADRL-SV-0063	0.63	15	45	3	5,330
ADRL-SV-0064	0.64	15	45	3	5,330
ADRL-SV-0065	0.65	15	45	3	5,330
ADRL-SV-0066	0.66	15	45	3	5,330
ADRL-SV-0067	0.67	15	45	3	5,330
ADRL-SV-0068	0.68	15	45	3	5,330
ADRL-SV-0069	0.69	15	45	3	5,330
ADRL-SV-0070	0.7	15	45	3	5,330
ADRL-SV-0071	0.71	15	45	3	5,330
ADRL-SV-0072	0.72	15	45	3	5,330
ADRL-SV-0073	0.73	15	45	3	5,330
ADRL-SV-0074	0.74	15	45	3	5,330
ADRL-SV-0075	0.75	15	45	3	5,330
ADRL-SV-0076	0.76	15	45	3	5,330
ADRL-SV-0077	0.77	15	45	3	5,330
ADRL-SV-0078	0.78	15	45	3	5,330
ADRL-SV-0079	0.79	15	45	3	5,330
ADRL-SV-0080	0.8	15	45	3	5,330
ADRL-SV-0081	0.81	15	45	3	5,330
ADRL-SV-0082	0.82	15	45	3	5,330
ADRL-SV-0083	0.83	15	45	3	5,330
ADRL-SV-0084	0.84	15	45	3	5,330
ADRL-SV-0085	0.85	15	45	3	5,330
ADRL-SV-0086	0.86	15	45	3	5,330
ADRL-SV-0087	0.87	15	45	3	5,330
ADRL-SV-0088	0.88	15	45	3	5,330
ADRL-SV-0089	0.89	15	45	3	5,330
ADRL-SV-0090	0.9	15	45	3	5,330

型番 CODE NUMBER	径 φD	刃長 ℓ	全長 L	シャンク d	定価 ¥
ADRL-SV-0091	0.91	15	45	3	5,330
ADRL-SV-0092	0.92	15	45	3	5,330
ADRL-SV-0093	0.93	15	45	3	5,330
ADRL-SV-0094	0.94	15	45	3	5,330
ADRL-SV-0095	0.95	15	45	3	5,330
ADRL-SV-0096	0.96	15	45	3	5,330
ADRL-SV-0097	0.97	15	45	3	5,330
ADRL-SV-0098	0.98	15	45	3	5,330
ADRL-SV-0099	0.99	15	45	3	5,330
ADRL-SV-0100	1	20	50	3	5,330
ADRL-SV-0101	1.01	20	50	3	5,330
ADRL-SV-0102	1.02	20	50	3	5,330
ADRL-SV-0103	1.03	20	50	3	5,330
ADRL-SV-0104	1.04	20	50	3	5,330
ADRL-SV-0105	1.05	20	50	3	5,330
ADRL-SV-0106	1.06	20	50	3	5,330
ADRL-SV-0107	1.07	20	50	3	5,330
ADRL-SV-0108	1.08	20	50	3	5,330
ADRL-SV-0109	1.09	20	50	3	5,330
ADRL-SV-0110	1.1	20	50	3	5,330
ADRL-SV-0111	1.11	20	50	3	5,330
ADRL-SV-0112	1.12	20	50	3	5,330
ADRL-SV-0113	1.13	20	50	3	5,330
ADRL-SV-0114	1.14	20	50	3	5,330
ADRL-SV-0115	1.15	20	50	3	5,330
ADRL-SV-0116	1.16	20	50	3	5,330
ADRL-SV-0117	1.17	20	50	3	5,330
ADRL-SV-0118	1.18	20	50	3	5,330
ADRL-SV-0119	1.19	20	50	3	5,330
ADRL-SV-0120	1.2	20	50	3	5,330
ADRL-SV-0121	1.21	20	50	3	5,330
ADRL-SV-0122	1.22	20	50	3	5,330
ADRL-SV-0123	1.23	20	50	3	5,330
ADRL-SV-0124	1.24	20	50	3	5,330
ADRL-SV-0125	1.25	20	50	3	5,330
ADRL-SV-0126	1.26	20	50	3	5,330
ADRL-SV-0127	1.27	20	50	3	5,330
ADRL-SV-0128	1.28	20	50	3	5,330
ADRL-SV-0129	1.29	20	50	3	5,330
ADRL-SV-0130	1.3	25	60	3	5,330
ADRL-SV-0131	1.31	25	60	3	5,330
ADRL-SV-0132	1.32	25	60	3	5,330
ADRL-SV-0133	1.33	25	60	3	5,330
ADRL-SV-0134	1.34	25	60	3	5,330

単位 Unit : mm

型番 CODE NUMBER	径 φD	刃長 ℓ	全長 L	シャンク d	定価 ¥
ADRL-SV-0135	1.35	25	60	3	5,330
ADRL-SV-0136	1.36	25	60	3	5,330
ADRL-SV-0137	1.37	25	60	3	5,330
ADRL-SV-0138	1.38	25	60	3	5,330
ADRL-SV-0139	1.39	25	60	3	5,330
ADRL-SV-0140	1.4	25	60	3	5,330
ADRL-SV-0141	1.41	25	60	3	5,330
ADRL-SV-0142	1.42	25	60	3	5,330
ADRL-SV-0143	1.43	25	60	3	5,330
ADRL-SV-0144	1.44	25	60	3	5,330
ADRL-SV-0145	1.45	25	60	3	5,330
ADRL-SV-0146	1.46	25	60	3	5,330
ADRL-SV-0147	1.47	25	60	3	5,330
ADRL-SV-0148	1.48	25	60	3	5,330
ADRL-SV-0149	1.49	25	60	3	5,330
ADRL-SV-0150	1.5	25	60	3	5,330
ADRL-SV-0151	1.51	25	60	3	5,330
ADRL-SV-0152	1.52	25	60	3	5,330
ADRL-SV-0153	1.53	25	60	3	5,330
ADRL-SV-0154	1.54	25	60	3	5,330
ADRL-SV-0155	1.55	25	60	3	5,330
ADRL-SV-0156	1.56	25	60	3	5,330
ADRL-SV-0157	1.57	25	60	3	5,330
ADRL-SV-0158	1.58	25	60	3	5,330
ADRL-SV-0159	1.59	25	60	3	5,330
ADRL-SV-0160	1.6	32	60	3	6,330
ADRL-SV-0161	1.61	32	60	3	6,330
ADRL-SV-0162	1.62	32	60	3	6,330
ADRL-SV-0163	1.63	32	60	3	6,330
ADRL-SV-0164	1.64	32	60	3	6,330
ADRL-SV-0165	1.65	32	60	3	6,330
ADRL-SV-0166	1.66	32	60	3	6,330
ADRL-SV-0167	1.67	32	60	3	6,330
ADRL-SV-0168	1.68	32	60	3	6,330
ADRL-SV-0169	1.69	32	60	3	6,330
ADRL-SV-0170	1.7	32	60	3	6,330
ADRL-SV-0171	1.71	32	60	3	6,330
ADRL-SV-0172	1.72	32	60	3	6,330
ADRL-SV-0173	1.73	32	60	3	6,330
ADRL-SV-0174	1.74	32	60	3	6,330
ADRL-SV-0175	1.75	32	60	3	6,330
ADRL-SV-0176	1.76	32	60	3	6,330
ADRL-SV-0177	1.77	32	60	3	6,330
ADRL-SV-0178	1.78	32	60	3	6,330

型番 CODE NUMBER	径 φD	刃長 ℓ	全長 L	シャンク d	定価 ¥
ADRL-SV-0179	1.79	32	60	3	6,330
ADRL-SV-0180	1.8	32	60	3	6,330
ADRL-SV-0181	1.81	32	60	3	6,330
ADRL-SV-0182	1.82	32	60	3	6,330
ADRL-SV-0183	1.83	32	60	3	6,330
ADRL-SV-0184	1.84	32	60	3	6,330
ADRL-SV-0185	1.85	32	60	3	6,330
ADRL-SV-0186	1.86	32	60	3	6,330
ADRL-SV-0187	1.87	32	60	3	6,330
ADRL-SV-0188	1.88	32	60	3	6,330
ADRL-SV-0189	1.89	32	60	3	6,330
ADRL-SV-0190	1.9	32	60	3	6,330
ADRL-SV-0191	1.91	32	60	3	6,330
ADRL-SV-0192	1.92	32	60	3	6,330
ADRL-SV-0193	1.93	32	60	3	6,330
ADRL-SV-0194	1.94	32	60	3	6,330
ADRL-SV-0195	1.95	32	60	3	6,330
ADRL-SV-0196	1.96	32	60	3	6,330
ADRL-SV-0197	1.97	32	60	3	6,330
ADRL-SV-0198	1.98	32	60	3	6,330
ADRL-SV-0199	1.99	32	60	3	6,330
ADRL-SV-0200	2	32	60	3	6,330
ADRL-SV-0201	2.01	32	60	3	6,330
ADRL-SV-0202	2.02	32	60	3	6,330
ADRL-SV-0203	2.03	32	60	3	6,330
ADRL-SV-0204	2.04	32	60	3	6,330
ADRL-SV-0205	2.05	32	60	3	6,330
ADRL-SV-0206	2.06	32	60	3	6,330
ADRL-SV-0207	2.07	32	60	3	6,330
ADRL-SV-0208	2.08	32	60	3	6,330
ADRL-SV-0209	2.09	32	60	3	6,330
ADRL-SV-0210	2.1	32	60	3	6,330
ADRL-SV-0211	2.11	32	60	3	6,330
ADRL-SV-0212	2.12	32	60	3	6,330
ADRL-SV-0213	2.13	32	60	3	6,330
ADRL-SV-0214	2.14	32	60	3	6,330
ADRL-SV-0215	2.15	32	60	3	6,330
ADRL-SV-0216	2.16	32	60	3	6,330
ADRL-SV-0217	2.17	32	60	3	6,330
ADRL-SV-0218	2.18	32	60	3	6,330
ADRL-SV-0219	2.19	32	60	3	6,330
ADRL-SV-0220	2.2	32	60	3	6,330
ADRL-SV-0221	2.21	32	60	3	6,330
ADRL-SV-0222	2.22	32	60	3	6,330

# ADRL-SV マイクロドリル “NEO-PRO” ロング刃 FCSCコーティング

単位 Unit : mm

型番 CODE NUMBER	径 φD	刃長 ℓ	全長 L	シャンク d	定価 ¥
ADRL-SV-0223	2.23	32	60	3	6,330
ADRL-SV-0224	2.24	32	60	3	6,330
ADRL-SV-0225	2.25	32	60	3	6,330
ADRL-SV-0226	2.26	32	60	3	6,330
ADRL-SV-0227	2.27	32	60	3	6,330
ADRL-SV-0228	2.28	32	60	3	6,330
ADRL-SV-0229	2.29	32	60	3	6,330
ADRL-SV-0230	2.3	32	60	3	6,330
ADRL-SV-0231	2.31	32	60	3	6,330
ADRL-SV-0232	2.32	32	60	3	6,330
ADRL-SV-0233	2.33	32	60	3	6,330
ADRL-SV-0234	2.34	32	60	3	6,330
ADRL-SV-0235	2.35	32	60	3	6,330
ADRL-SV-0236	2.36	32	60	3	6,330
ADRL-SV-0237	2.37	32	60	3	6,330
ADRL-SV-0238	2.38	32	60	3	6,330
ADRL-SV-0239	2.39	32	60	3	6,330
ADRL-SV-0240	2.4	32	60	3	6,330
ADRL-SV-0241	2.41	32	60	3	6,330
ADRL-SV-0242	2.42	32	60	3	6,330
ADRL-SV-0243	2.43	32	60	3	6,330
ADRL-SV-0244	2.44	32	60	3	6,330
ADRL-SV-0245	2.45	32	60	3	6,330
ADRL-SV-0246	2.46	32	60	3	6,330
ADRL-SV-0247	2.47	32	60	3	6,330
ADRL-SV-0248	2.48	32	60	3	6,330
ADRL-SV-0249	2.49	32	60	3	6,330
ADRL-SV-0250	2.5	32	60	3	6,330
ADRL-SV-0251	2.51	32	60	3	6,330
ADRL-SV-0252	2.52	32	60	3	6,330
ADRL-SV-0253	2.53	32	60	3	6,330
ADRL-SV-0254	2.54	32	60	3	6,330
ADRL-SV-0255	2.55	32	60	3	6,330
ADRL-SV-0256	2.56	32	60	3	6,330
ADRL-SV-0257	2.57	32	60	3	6,330
ADRL-SV-0258	2.58	32	60	3	6,330
ADRL-SV-0259	2.59	32	60	3	6,330
ADRL-SV-0260	2.6	32	60	3	6,330
ADRL-SV-0261	2.61	32	60	3	6,330
ADRL-SV-0262	2.62	32	60	3	6,330
ADRL-SV-0263	2.63	32	60	3	6,330
ADRL-SV-0264	2.64	32	60	3	6,330
ADRL-SV-0265	2.65	32	60	3	6,330
ADRL-SV-0266	2.66	32	60	3	6,330

型番 CODE NUMBER	径 φD	刃長 ℓ	全長 L	シャンク d	定価 ¥
ADRL-SV-0267	2.67	32	60	3	6,330
ADRL-SV-0268	2.68	32	60	3	6,330
ADRL-SV-0269	2.69	32	60	3	6,330
ADRL-SV-0270	2.7	40	65	3	6,330
ADRL-SV-0271	2.71	40	65	3	6,330
ADRL-SV-0272	2.72	40	65	3	6,330
ADRL-SV-0273	2.73	40	65	3	6,330
ADRL-SV-0274	2.74	40	65	3	6,330
ADRL-SV-0275	2.75	40	65	3	6,330
ADRL-SV-0276	2.76	40	65	3	6,330
ADRL-SV-0277	2.77	40	65	3	6,330
ADRL-SV-0278	2.78	40	65	3	6,330
ADRL-SV-0279	2.79	40	65	3	6,330
ADRL-SV-0280	2.8	40	65	3	6,330
ADRL-SV-0281	2.81	40	65	3	6,330
ADRL-SV-0282	2.82	40	65	3	6,330
ADRL-SV-0283	2.83	40	65	3	6,330
ADRL-SV-0284	2.84	40	65	3	6,330
ADRL-SV-0285	2.85	40	65	3	6,330
ADRL-SV-0286	2.86	40	65	3	6,330
ADRL-SV-0287	2.87	40	65	3	6,330
ADRL-SV-0288	2.88	40	65	3	6,330
ADRL-SV-0289	2.89	40	65	3	6,330
ADRL-SV-0290	2.9	40	65	3	6,330
ADRL-SV-0291	2.91	40	65	3	6,330
ADRL-SV-0292	2.92	40	65	3	6,330
ADRL-SV-0293	2.93	40	65	3	6,330
ADRL-SV-0294	2.94	40	65	3	6,330
ADRL-SV-0295	2.95	40	65	3	6,330
ADRL-SV-0296	2.96	40	65	3	6,330
ADRL-SV-0297	2.97	40	65	3	6,330
ADRL-SV-0298	2.98	40	65	3	6,330
ADRL-SV-0299	2.99	40	65	3	6,330
ADRL-SV-0300	3	40	65	3	6,330

# 難削材用 マイクロドリル 標準刃長

Micro Drill for Hard-to-Cut Materials

FCSコーティング

## ADR-SUS

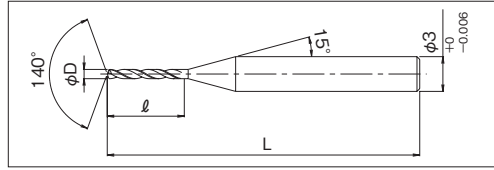

■ 軟鋼難削材 SUS420/430、コバルト、インコネル、ハステロイ、純ニッケル等に長寿命を実現。  
Long tool life is achieved for mild steel materials hard-to-cut such as SUS420/430, Kovar, Inconel etc.

■ 高剛性設計で難削材加工時のドリル折損を防止。  
High stiffness tool design prevents the breakage in drilling hard-to-cut materials.

刃径公差：+0~-0.01  
φD Tolerance



φD ≥ 0.3

単位 Unit : mm

型番 CODE NUMBER	径 φD	刃長 ℓ	全長 L	シャンク d	定価 ¥
ADR-SUS-0010	0.1	1	38	3	6,100
ADR-SUS-0011	0.11	1.1	38	3	6,100
ADR-SUS-0012	0.12	1.2	38	3	6,100
ADR-SUS-0013	0.13	1.3	38	3	6,100
ADR-SUS-0014	0.14	1.4	38	3	6,100
ADR-SUS-0015	0.15	1.5	38	3	5,600
ADR-SUS-0016	0.16	1.5	38	3	5,600
ADR-SUS-0017	0.17	1.5	38	3	5,600
ADR-SUS-0018	0.18	1.8	38	3	5,600
ADR-SUS-0019	0.19	1.8	38	3	5,600
ADR-SUS-0020	0.2	2	38	3	5,270
ADR-SUS-0021	0.21	2	38	3	5,270
ADR-SUS-0022	0.22	2	38	3	5,270
ADR-SUS-0023	0.23	2.3	38	3	5,270
ADR-SUS-0024	0.24	2.3	38	3	5,270
ADR-SUS-0025	0.25	2.5	38	3	5,270
ADR-SUS-0026	0.26	2.5	38	3	5,270
ADR-SUS-0027	0.27	2.5	38	3	5,270
ADR-SUS-0028	0.28	2.8	38	3	5,270
ADR-SUS-0029	0.29	2.8	38	3	5,270
ADR-SUS-0030	0.3	3	38	3	4,640
ADR-SUS-0031	0.31	3	38	3	4,970
ADR-SUS-0032	0.32	3	38	3	4,970
ADR-SUS-0033	0.33	3.3	38	3	4,970
ADR-SUS-0034	0.34	3.3	38	3	4,970
ADR-SUS-0035	0.35	3.5	38	3	4,970

型番 CODE NUMBER	径 φD	刃長 ℓ	全長 L	シャンク d	定価 ¥
ADR-SUS-0036	0.36	3.5	38	3	4,970
ADR-SUS-0037	0.37	3.5	38	3	4,970
ADR-SUS-0038	0.38	3.8	38	3	4,970
ADR-SUS-0039	0.39	3.8	38	3	4,970
ADR-SUS-0040	0.4	4	38	3	4,640
ADR-SUS-0041	0.41	4	38	3	4,970
ADR-SUS-0042	0.42	4	38	3	4,970
ADR-SUS-0043	0.43	4	38	3	4,970
ADR-SUS-0044	0.44	4	38	3	4,970
ADR-SUS-0045	0.45	4.5	38	3	4,970
ADR-SUS-0046	0.46	4.5	38	3	4,970
ADR-SUS-0047	0.47	4.5	38	3	4,970
ADR-SUS-0048	0.48	4.5	38	3	4,970
ADR-SUS-0049	0.49	4.5	38	3	4,970
ADR-SUS-0050	0.5	5	38	3	4,640
ADR-SUS-0051	0.51	5	38	3	4,970
ADR-SUS-0052	0.52	5	38	3	4,970
ADR-SUS-0053	0.53	5	38	3	4,970
ADR-SUS-0054	0.54	5	38	3	4,970
ADR-SUS-0055	0.55	5.5	38	3	4,970
ADR-SUS-0056	0.56	5.5	38	3	4,970
ADR-SUS-0057	0.57	5.5	38	3	4,970
ADR-SUS-0058	0.58	5.5	38	3	4,970
ADR-SUS-0059	0.59	5.5	38	3	4,970
ADR-SUS-0060	0.6	6	38	3	4,640
ADR-SUS-0061	0.61	6	38	3	4,970

Next Page ▶

型番 CODE NUMBER	径 φD	刃長 ℓ	全長 L	シャンク d	定価 ¥
ADR-SUS-0062	0.62	6	38	3	4,970
ADR-SUS-0063	0.63	6	38	3	4,970
ADR-SUS-0064	0.64	6	38	3	4,970
ADR-SUS-0065	0.65	6.5	38	3	4,970
ADR-SUS-0066	0.66	6.5	38	3	4,970
ADR-SUS-0067	0.67	6.5	38	3	4,970
ADR-SUS-0068	0.68	6.5	38	3	4,970
ADR-SUS-0069	0.69	6.5	38	3	4,970
ADR-SUS-0070	0.7	7	38	3	4,640
ADR-SUS-0071	0.71	7	38	3	4,970
ADR-SUS-0072	0.72	7	38	3	4,970
ADR-SUS-0073	0.73	7	38	3	4,970
ADR-SUS-0074	0.74	7	38	3	4,970
ADR-SUS-0075	0.75	7.5	38	3	4,970
ADR-SUS-0076	0.76	7.5	38	3	4,970
ADR-SUS-0077	0.77	7.5	38	3	4,970
ADR-SUS-0078	0.78	7.5	38	3	4,970
ADR-SUS-0079	0.79	7.5	38	3	4,970
ADR-SUS-0080	0.8	8	38	3	4,640
ADR-SUS-0081	0.81	8	38	3	4,970
ADR-SUS-0082	0.82	8	38	3	4,970
ADR-SUS-0083	0.83	8	38	3	4,970
ADR-SUS-0084	0.84	8	38	3	4,970
ADR-SUS-0085	0.85	8	38	3	4,970
ADR-SUS-0086	0.86	8	38	3	4,970
ADR-SUS-0087	0.87	8	38	3	4,970
ADR-SUS-0088	0.88	8	38	3	4,970
ADR-SUS-0089	0.89	8	38	3	4,970
ADR-SUS-0090	0.9	9	38	3	4,640
ADR-SUS-0091	0.91	9	38	3	4,970
ADR-SUS-0092	0.92	9	38	3	4,970
ADR-SUS-0093	0.93	9	38	3	4,970
ADR-SUS-0094	0.94	9	38	3	4,970
ADR-SUS-0095	0.95	9	38	3	4,970
ADR-SUS-0096	0.96	9	38	3	4,970
ADR-SUS-0097	0.97	9	38	3	4,970
ADR-SUS-0098	0.98	9	38	3	4,970
ADR-SUS-0099	0.99	9	38	3	4,970
ADR-SUS-0100	1	10	38	3	4,300
ADR-SUS-0101	1.01	10	38	3	4,640
ADR-SUS-0102	1.02	10	38	3	4,640
ADR-SUS-0103	1.03	10	38	3	4,640
ADR-SUS-0104	1.04	10	38	3	4,640
ADR-SUS-0105	1.05	10	38	3	4,640

型番 CODE NUMBER	径 φD	刃長 ℓ	全長 L	シャンク d	定価 ¥
ADR-SUS-0106	1.06	10	38	3	4,640
ADR-SUS-0107	1.07	10	38	3	4,640
ADR-SUS-0108	1.08	10	38	3	4,640
ADR-SUS-0109	1.09	10	38	3	4,640
ADR-SUS-0110	1.1	10	38	3	4,300
ADR-SUS-0111	1.11	10	38	3	4,640
ADR-SUS-0112	1.12	10	38	3	4,640
ADR-SUS-0113	1.13	10	38	3	4,640
ADR-SUS-0114	1.14	10	38	3	4,640
ADR-SUS-0115	1.15	10	38	3	4,640
ADR-SUS-0116	1.16	10	38	3	4,640
ADR-SUS-0117	1.17	10	38	3	4,640
ADR-SUS-0118	1.18	10	38	3	4,640
ADR-SUS-0119	1.19	10	38	3	4,640
ADR-SUS-0120	1.2	10	38	3	4,300
ADR-SUS-0121	1.21	10	38	3	4,640
ADR-SUS-0122	1.22	10	38	3	4,640
ADR-SUS-0123	1.23	10	38	3	4,640
ADR-SUS-0124	1.24	10	38	3	4,640
ADR-SUS-0125	1.25	10	38	3	4,640
ADR-SUS-0126	1.26	10	38	3	4,640
ADR-SUS-0127	1.27	10	38	3	4,640
ADR-SUS-0128	1.28	10	38	3	4,640
ADR-SUS-0129	1.29	10	38	3	4,640
ADR-SUS-0130	1.3	10	38	3	4,300
ADR-SUS-0131	1.31	10	38	3	4,640
ADR-SUS-0132	1.32	10	38	3	4,640
ADR-SUS-0133	1.33	10	38	3	4,640
ADR-SUS-0134	1.34	10	38	3	4,640
ADR-SUS-0135	1.35	10	38	3	4,640
ADR-SUS-0136	1.36	10	38	3	4,640
ADR-SUS-0137	1.37	10	38	3	4,640
ADR-SUS-0138	1.38	10	38	3	4,640
ADR-SUS-0139	1.39	10	38	3	4,640
ADR-SUS-0140	1.4	10	38	3	4,300
ADR-SUS-0141	1.41	10	38	3	4,640
ADR-SUS-0142	1.42	10	38	3	4,640
ADR-SUS-0143	1.43	10	38	3	4,640
ADR-SUS-0144	1.44	10	38	3	4,640
ADR-SUS-0145	1.45	10	38	3	4,640
ADR-SUS-0146	1.46	10	38	3	4,640
ADR-SUS-0147	1.47	10	38	3	4,640
ADR-SUS-0148	1.48	10	38	3	4,640
ADR-SUS-0149	1.49	10	38	3	4,640



単位 Unit : mm

型番 CODE NUMBER	径 φD	刃長 ℓ	全長 L	シャンク d	定価 ¥
ADR-SUS-0150	1.5	10	38	3	4,300
ADR-SUS-0151	1.51	10	38	3	4,640
ADR-SUS-0152	1.52	10	38	3	4,640
ADR-SUS-0153	1.53	10	38	3	4,640
ADR-SUS-0154	1.54	10	38	3	4,640
ADR-SUS-0155	1.55	10	38	3	4,640
ADR-SUS-0156	1.56	10	38	3	4,640
ADR-SUS-0157	1.57	10	38	3	4,640
ADR-SUS-0158	1.58	10	38	3	4,640
ADR-SUS-0159	1.59	10	38	3	4,640
ADR-SUS-0160	1.6	12	45	3	4,300
ADR-SUS-0161	1.61	12	45	3	4,640
ADR-SUS-0162	1.62	12	45	3	4,640
ADR-SUS-0163	1.63	12	45	3	4,640
ADR-SUS-0164	1.64	12	45	3	4,640
ADR-SUS-0165	1.65	12	45	3	4,640
ADR-SUS-0166	1.66	12	45	3	4,640
ADR-SUS-0167	1.67	12	45	3	4,640
ADR-SUS-0168	1.68	12	45	3	4,640
ADR-SUS-0169	1.69	12	45	3	4,640
ADR-SUS-0170	1.7	12	45	3	4,300
ADR-SUS-0171	1.71	12	45	3	4,640
ADR-SUS-0172	1.72	12	45	3	4,640
ADR-SUS-0173	1.73	12	45	3	4,640
ADR-SUS-0174	1.74	12	45	3	4,640
ADR-SUS-0175	1.75	12	45	3	4,640
ADR-SUS-0176	1.76	12	45	3	4,640
ADR-SUS-0177	1.77	12	45	3	4,640
ADR-SUS-0178	1.78	12	45	3	4,640
ADR-SUS-0179	1.79	12	45	3	4,640
ADR-SUS-0180	1.8	12	45	3	4,300
ADR-SUS-0181	1.81	12	45	3	4,640
ADR-SUS-0182	1.82	12	45	3	4,640
ADR-SUS-0183	1.83	12	45	3	4,640
ADR-SUS-0184	1.84	12	45	3	4,640
ADR-SUS-0185	1.85	12	45	3	4,640
ADR-SUS-0186	1.86	12	45	3	4,640
ADR-SUS-0187	1.87	12	45	3	4,640
ADR-SUS-0188	1.88	12	45	3	4,640
ADR-SUS-0189	1.89	12	45	3	4,640
ADR-SUS-0190	1.9	12	45	3	4,300
ADR-SUS-0191	1.91	12	45	3	4,640
ADR-SUS-0192	1.92	12	45	3	4,640
ADR-SUS-0193	1.93	12	45	3	4,640

型番 CODE NUMBER	径 φD	刃長 ℓ	全長 L	シャンク d	定価 ¥
ADR-SUS-0194	1.94	12	45	3	4,640
ADR-SUS-0195	1.95	12	45	3	4,640
ADR-SUS-0196	1.96	12	45	3	4,640
ADR-SUS-0197	1.97	12	45	3	4,640
ADR-SUS-0198	1.98	12	45	3	4,640
ADR-SUS-0199	1.99	12	45	3	4,640
ADR-SUS-0200	2	12	45	3	4,300
ADR-SUS-0201	2.01	12	45	3	4,640
ADR-SUS-0202	2.02	12	45	3	4,640
ADR-SUS-0203	2.03	12	45	3	4,640
ADR-SUS-0204	2.04	12	45	3	4,640
ADR-SUS-0205	2.05	12	45	3	4,640
ADR-SUS-0206	2.06	12	45	3	4,640
ADR-SUS-0207	2.07	12	45	3	4,640
ADR-SUS-0208	2.08	12	45	3	4,640
ADR-SUS-0209	2.09	12	45	3	4,640
ADR-SUS-0210	2.1	12	45	3	4,300
ADR-SUS-0211	2.11	12	45	3	4,640
ADR-SUS-0212	2.12	12	45	3	4,640
ADR-SUS-0213	2.13	12	45	3	4,640
ADR-SUS-0214	2.14	12	45	3	4,640
ADR-SUS-0215	2.15	12	45	3	4,640
ADR-SUS-0216	2.16	12	45	3	4,640
ADR-SUS-0217	2.17	12	45	3	4,640
ADR-SUS-0218	2.18	12	45	3	4,640
ADR-SUS-0219	2.19	12	45	3	4,640
ADR-SUS-0220	2.2	12	45	3	4,300
ADR-SUS-0221	2.21	12	45	3	4,640
ADR-SUS-0222	2.22	12	45	3	4,640
ADR-SUS-0223	2.23	12	45	3	4,640
ADR-SUS-0224	2.24	12	45	3	4,640
ADR-SUS-0225	2.25	12	45	3	4,640
ADR-SUS-0226	2.26	12	45	3	4,640
ADR-SUS-0227	2.27	12	45	3	4,640
ADR-SUS-0228	2.28	12	45	3	4,640
ADR-SUS-0229	2.29	12	45	3	4,640
ADR-SUS-0230	2.3	12	45	3	4,300
ADR-SUS-0231	2.31	12	45	3	4,640
ADR-SUS-0232	2.32	12	45	3	4,640
ADR-SUS-0233	2.33	12	45	3	4,640
ADR-SUS-0234	2.34	12	45	3	4,640
ADR-SUS-0235	2.35	12	45	3	4,640
ADR-SUS-0236	2.36	12	45	3	4,640
ADR-SUS-0237	2.37	12	45	3	4,640

Next Page ▶



# 難削材用 マイクロドリル ロング刃

Micro Drill for Hard-to-Cut Materials, Long Flute

FCSコーティング

## ADRL-SUS

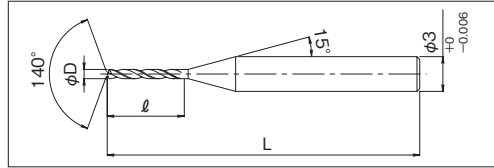

■ 軟鋼難削材 SUS420/430、コバルト、インコネル、ハステロイ、純ニッケル等に長寿命を実現。  
Long tool life is achieved for mild steel materials hard-to-cut such as SUS420/430, Kovar, Inconel etc.

■ 高剛性設計で難削材加工時のドリル折損を防止。  
High stiffness tool design prevents the breakage in drilling hard-to-cut materials.

刃径公差：+0~-0.01  
φD Tolerance



φD≥0.3

単位 Unit : mm

型番 CODENUMBER	径 φD	刃長 ℓ	全長 L	シャンク d	定価 ¥
ADRL-SUS-0010	0.1	1.5	38	3	6,830
ADRL-SUS-0011	0.11	1.7	38	3	6,830
ADRL-SUS-0012	0.12	1.8	38	3	6,830
ADRL-SUS-0013	0.13	2	38	3	6,830
ADRL-SUS-0014	0.14	2	38	3	6,830
ADRL-SUS-0015	0.15	2.3	38	3	6,430
ADRL-SUS-0016	0.16	2.3	38	3	6,430
ADRL-SUS-0017	0.17	2.3	38	3	6,430
ADRL-SUS-0018	0.18	2.7	38	3	6,430
ADRL-SUS-0019	0.19	2.7	38	3	6,430
ADRL-SUS-0020	0.2	3	38	3	6,000
ADRL-SUS-0021	0.21	3	38	3	6,130
ADRL-SUS-0022	0.22	3	38	3	6,130
ADRL-SUS-0023	0.23	3.5	38	3	6,130
ADRL-SUS-0024	0.24	3.5	38	3	6,130
ADRL-SUS-0025	0.25	3.8	38	3	6,130
ADRL-SUS-0026	0.26	3.8	38	3	6,130
ADRL-SUS-0027	0.27	3.8	38	3	6,130
ADRL-SUS-0028	0.28	4.2	38	3	6,130
ADRL-SUS-0029	0.29	4.2	38	3	6,130
ADRL-SUS-0030	0.3	4.5	38	3	5,800
ADRL-SUS-0031	0.31	4.5	38	3	5,970
ADRL-SUS-0032	0.32	4.5	38	3	5,970
ADRL-SUS-0033	0.33	5	38	3	5,970
ADRL-SUS-0034	0.34	5	38	3	5,970
ADRL-SUS-0035	0.35	5.3	38	3	5,970

型番 CODENUMBER	径 φD	刃長 ℓ	全長 L	シャンク d	定価 ¥
ADRL-SUS-0036	0.36	5.3	38	3	5,970
ADRL-SUS-0037	0.37	5.3	38	3	5,970
ADRL-SUS-0038	0.38	5.7	38	3	5,970
ADRL-SUS-0039	0.39	5.7	38	3	5,970
ADRL-SUS-0040	0.4	6	38	3	5,630
ADRL-SUS-0041	0.41	6	38	3	5,970
ADRL-SUS-0042	0.42	6	38	3	5,970
ADRL-SUS-0043	0.43	6	38	3	5,970
ADRL-SUS-0044	0.44	6	38	3	5,970
ADRL-SUS-0045	0.45	7	38	3	5,970
ADRL-SUS-0046	0.46	7	38	3	5,970
ADRL-SUS-0047	0.47	7	38	3	5,970
ADRL-SUS-0048	0.48	7	38	3	5,970
ADRL-SUS-0049	0.49	7	38	3	5,970
ADRL-SUS-0050	0.5	7.5	38	3	5,630
ADRL-SUS-0051	0.51	7.5	38	3	5,970
ADRL-SUS-0052	0.52	7.5	38	3	5,970
ADRL-SUS-0053	0.53	7.5	38	3	5,970
ADRL-SUS-0054	0.54	7.5	38	3	5,970
ADRL-SUS-0055	0.55	8.5	38	3	5,970
ADRL-SUS-0056	0.56	8.5	38	3	5,970
ADRL-SUS-0057	0.57	8.5	38	3	5,970
ADRL-SUS-0058	0.58	8.5	38	3	5,970
ADRL-SUS-0059	0.59	8.5	38	3	5,970
ADRL-SUS-0060	0.6	9	38	3	5,630
ADRL-SUS-0061	0.61	9	38	3	5,970

Next Page ▶

切削条件 Cutting Condition P.169

# ADRL-SUS 難削材用マイクロドリル ロング刃 FCSコーティング

単位 Unit : mm

型番 CODE NUMBER	径 φD	刃長 ℓ	全長 L	シャンク d	定価 ¥
ADRL-SUS-0062	0.62	9	38	3	5,970
ADRL-SUS-0063	0.63	9	38	3	5,970
ADRL-SUS-0064	0.64	9	38	3	5,970
ADRL-SUS-0065	0.65	10	38	3	5,970
ADRL-SUS-0066	0.66	10	38	3	5,970
ADRL-SUS-0067	0.67	10	38	3	5,970
ADRL-SUS-0068	0.68	10	38	3	5,970
ADRL-SUS-0069	0.69	10	38	3	5,970
ADRL-SUS-0070	0.7	10.5	38	3	5,630
ADRL-SUS-0071	0.71	10.5	38	3	5,970
ADRL-SUS-0072	0.72	10.5	38	3	5,970
ADRL-SUS-0073	0.73	10.5	38	3	5,970
ADRL-SUS-0074	0.74	10.5	38	3	5,970
ADRL-SUS-0075	0.75	11.5	38	3	5,970
ADRL-SUS-0076	0.76	11.5	38	3	5,970
ADRL-SUS-0077	0.77	11.5	38	3	5,970
ADRL-SUS-0078	0.78	11.5	38	3	5,970
ADRL-SUS-0079	0.79	11.5	38	3	5,970
ADRL-SUS-0080	0.8	12.5	45	3	5,630
ADRL-SUS-0081	0.81	12.5	45	3	5,970
ADRL-SUS-0082	0.82	12.5	45	3	5,970
ADRL-SUS-0083	0.83	12.5	45	3	5,970
ADRL-SUS-0084	0.84	12.5	45	3	5,970
ADRL-SUS-0085	0.85	12.5	45	3	5,970
ADRL-SUS-0086	0.86	12.5	45	3	5,970
ADRL-SUS-0087	0.87	12.5	45	3	5,970
ADRL-SUS-0088	0.88	12.5	45	3	5,970
ADRL-SUS-0089	0.89	12.5	45	3	5,970
ADRL-SUS-0090	0.9	14	45	3	5,630
ADRL-SUS-0091	0.91	14	45	3	5,970
ADRL-SUS-0092	0.92	14	45	3	5,970
ADRL-SUS-0093	0.93	14	45	3	5,970
ADRL-SUS-0094	0.94	14	45	3	5,970
ADRL-SUS-0095	0.95	14	45	3	5,970
ADRL-SUS-0096	0.96	14	45	3	5,970
ADRL-SUS-0097	0.97	14	45	3	5,970
ADRL-SUS-0098	0.98	14	45	3	5,970
ADRL-SUS-0099	0.99	14	45	3	5,970
ADRL-SUS-0100	1	15	45	3	5,430
ADRL-SUS-0101	1.01	15	45	3	5,770
ADRL-SUS-0102	1.02	15	45	3	5,770
ADRL-SUS-0103	1.03	15	45	3	5,770
ADRL-SUS-0104	1.04	15	45	3	5,770
ADRL-SUS-0105	1.05	15	45	3	5,770

型番 CODE NUMBER	径 φD	刃長 ℓ	全長 L	シャンク d	定価 ¥
ADRL-SUS-0106	1.06	15	45	3	5,770
ADRL-SUS-0107	1.07	15	45	3	5,770
ADRL-SUS-0108	1.08	15	45	3	5,770
ADRL-SUS-0109	1.09	15	45	3	5,770
ADRL-SUS-0110	1.1	15	45	3	5,430
ADRL-SUS-0111	1.11	15	45	3	5,770
ADRL-SUS-0112	1.12	15	45	3	5,770
ADRL-SUS-0113	1.13	15	45	3	5,770
ADRL-SUS-0114	1.14	15	45	3	5,770
ADRL-SUS-0115	1.15	15	45	3	5,770
ADRL-SUS-0116	1.16	15	45	3	5,770
ADRL-SUS-0117	1.17	15	45	3	5,770
ADRL-SUS-0118	1.18	15	45	3	5,770
ADRL-SUS-0119	1.19	15	45	3	5,770
ADRL-SUS-0120	1.2	15	45	3	5,430
ADRL-SUS-0121	1.21	15	45	3	5,770
ADRL-SUS-0122	1.22	15	45	3	5,770
ADRL-SUS-0123	1.23	15	45	3	5,770
ADRL-SUS-0124	1.24	15	45	3	5,770
ADRL-SUS-0125	1.25	15	45	3	5,770
ADRL-SUS-0126	1.26	15	45	3	5,770
ADRL-SUS-0127	1.27	15	45	3	5,770
ADRL-SUS-0128	1.28	15	45	3	5,770
ADRL-SUS-0129	1.29	15	45	3	5,770
ADRL-SUS-0130	1.3	17	45	3	5,430
ADRL-SUS-0131	1.31	17	45	3	5,770
ADRL-SUS-0132	1.32	17	45	3	5,770
ADRL-SUS-0133	1.33	17	45	3	5,770
ADRL-SUS-0134	1.34	17	45	3	5,770
ADRL-SUS-0135	1.35	17	45	3	5,770
ADRL-SUS-0136	1.36	17	45	3	5,770
ADRL-SUS-0137	1.37	17	45	3	5,770
ADRL-SUS-0138	1.38	17	45	3	5,770
ADRL-SUS-0139	1.39	17	45	3	5,770
ADRL-SUS-0140	1.4	17	45	3	5,430
ADRL-SUS-0141	1.41	17	45	3	5,770
ADRL-SUS-0142	1.42	17	45	3	5,770
ADRL-SUS-0143	1.43	17	45	3	5,770
ADRL-SUS-0144	1.44	17	45	3	5,770
ADRL-SUS-0145	1.45	17	45	3	5,770
ADRL-SUS-0146	1.46	17	45	3	5,770
ADRL-SUS-0147	1.47	17	45	3	5,770
ADRL-SUS-0148	1.48	17	45	3	5,770
ADRL-SUS-0149	1.49	17	45	3	5,770

ループドリル  
Micro Drill

単位 Unit : mm

型番 CODE NUMBER	径 φD	刃長 ℓ	全長 L	シャンク d	定価 ¥
ADRL-SUS-0150	1.5	17	45	3	5,430
ADRL-SUS-0151	1.51	17	45	3	5,770
ADRL-SUS-0152	1.52	17	45	3	5,770
ADRL-SUS-0153	1.53	17	45	3	5,770
ADRL-SUS-0154	1.54	17	45	3	5,770
ADRL-SUS-0155	1.55	17	45	3	5,770
ADRL-SUS-0156	1.56	17	45	3	5,770
ADRL-SUS-0157	1.57	17	45	3	5,770
ADRL-SUS-0158	1.58	17	45	3	5,770
ADRL-SUS-0159	1.59	17	45	3	5,770
ADRL-SUS-0160	1.6	20	50	3	5,500
ADRL-SUS-0161	1.61	20	50	3	5,830
ADRL-SUS-0162	1.62	20	50	3	5,830
ADRL-SUS-0163	1.63	20	50	3	5,830
ADRL-SUS-0164	1.64	20	50	3	5,830
ADRL-SUS-0165	1.65	20	50	3	5,830
ADRL-SUS-0166	1.66	20	50	3	5,830
ADRL-SUS-0167	1.67	20	50	3	5,830
ADRL-SUS-0168	1.68	20	50	3	5,830
ADRL-SUS-0169	1.69	20	50	3	5,830
ADRL-SUS-0170	1.7	20	50	3	5,500
ADRL-SUS-0171	1.71	20	50	3	5,830
ADRL-SUS-0172	1.72	20	50	3	5,830
ADRL-SUS-0173	1.73	20	50	3	5,830
ADRL-SUS-0174	1.74	20	50	3	5,830
ADRL-SUS-0175	1.75	20	50	3	5,830
ADRL-SUS-0176	1.76	20	50	3	5,830
ADRL-SUS-0177	1.77	20	50	3	5,830
ADRL-SUS-0178	1.78	20	50	3	5,830
ADRL-SUS-0179	1.79	20	50	3	5,830
ADRL-SUS-0180	1.8	20	50	3	5,500
ADRL-SUS-0181	1.81	20	50	3	5,830
ADRL-SUS-0182	1.82	20	50	3	5,830
ADRL-SUS-0183	1.83	20	50	3	5,830
ADRL-SUS-0184	1.84	20	50	3	5,830
ADRL-SUS-0185	1.85	20	50	3	5,830
ADRL-SUS-0186	1.86	20	50	3	5,830
ADRL-SUS-0187	1.87	20	50	3	5,830
ADRL-SUS-0188	1.88	20	50	3	5,830
ADRL-SUS-0189	1.89	20	50	3	5,830
ADRL-SUS-0190	1.9	20	50	3	5,500
ADRL-SUS-0191	1.91	20	50	3	5,830
ADRL-SUS-0192	1.92	20	50	3	5,830
ADRL-SUS-0193	1.93	20	50	3	5,830

型番 CODE NUMBER	径 φD	刃長 ℓ	全長 L	シャンク d	定価 ¥
ADRL-SUS-0194	1.94	20	50	3	5,830
ADRL-SUS-0195	1.95	20	50	3	5,830
ADRL-SUS-0196	1.96	20	50	3	5,830
ADRL-SUS-0197	1.97	20	50	3	5,830
ADRL-SUS-0198	1.98	20	50	3	5,830
ADRL-SUS-0199	1.99	20	50	3	5,830
ADRL-SUS-0200	2	20	50	3	5,500
ADRL-SUS-0201	2.01	20	50	3	5,830
ADRL-SUS-0202	2.02	20	50	3	5,830
ADRL-SUS-0203	2.03	20	50	3	5,830
ADRL-SUS-0204	2.04	20	50	3	5,830
ADRL-SUS-0205	2.05	20	50	3	5,830
ADRL-SUS-0206	2.06	20	50	3	5,830
ADRL-SUS-0207	2.07	20	50	3	5,830
ADRL-SUS-0208	2.08	20	50	3	5,830
ADRL-SUS-0209	2.09	20	50	3	5,830
ADRL-SUS-0210	2.1	20	50	3	5,500
ADRL-SUS-0211	2.11	20	50	3	5,830
ADRL-SUS-0212	2.12	20	50	3	5,830
ADRL-SUS-0213	2.13	20	50	3	5,830
ADRL-SUS-0214	2.14	20	50	3	5,830
ADRL-SUS-0215	2.15	20	50	3	5,830
ADRL-SUS-0216	2.16	20	50	3	5,830
ADRL-SUS-0217	2.17	20	50	3	5,830
ADRL-SUS-0218	2.18	20	50	3	5,830
ADRL-SUS-0219	2.19	20	50	3	5,830
ADRL-SUS-0220	2.2	22	50	3	5,500
ADRL-SUS-0221	2.21	22	50	3	5,830
ADRL-SUS-0222	2.22	22	50	3	5,830
ADRL-SUS-0223	2.23	22	50	3	5,830
ADRL-SUS-0224	2.24	22	50	3	5,830
ADRL-SUS-0225	2.25	22	50	3	5,830
ADRL-SUS-0226	2.26	22	50	3	5,830
ADRL-SUS-0227	2.27	22	50	3	5,830
ADRL-SUS-0228	2.28	22	50	3	5,830
ADRL-SUS-0229	2.29	22	50	3	5,830
ADRL-SUS-0230	2.3	22	50	3	5,500
ADRL-SUS-0231	2.31	22	50	3	5,830
ADRL-SUS-0232	2.32	22	50	3	5,830
ADRL-SUS-0233	2.33	22	50	3	5,830
ADRL-SUS-0234	2.34	22	50	3	5,830
ADRL-SUS-0235	2.35	22	50	3	5,830
ADRL-SUS-0236	2.36	22	50	3	5,830
ADRL-SUS-0237	2.37	22	50	3	5,830

Next Page ▶



# ルーマドリル 1mmシャンク

Micro Drill, 1mm shank

## AMSD

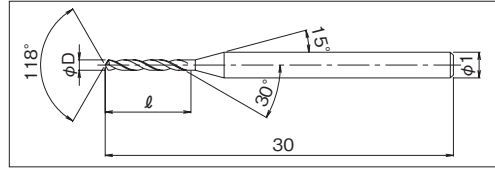

φ0.05～φ0.09は首逃げ2段形状です。

■ 精密細穴加工用1mmシャンクドリルです。

1mm shank drill series for drilling precision small holes.

刃径公差：+0～-0.005

φD Tolerance



単位 Unit : mm

型番 CODE NUMBER	径 φD	刃長 ℓ	全長 L	シャンク d	定価 ¥
AMSD-0005	0.05	0.5	30	1	12,500
AMSD-0006	0.06	0.5	30	1	11,000
AMSD-0007	0.07	0.5	30	1	9,000
AMSD-0008	0.08	0.5	30	1	6,750
AMSD-0009	0.09	0.5	30	1	5,750
AMSD-0010	0.1	1	30	1	4,000
AMSD-0011	0.11	1	30	1	4,000
AMSD-0012	0.12	1	30	1	4,000
AMSD-0013	0.13	1	30	1	4,000
AMSD-0014	0.14	1	30	1	4,000
AMSD-0015	0.15	1.5	30	1	3,600
AMSD-0016	0.16	1.5	30	1	3,600
AMSD-0017	0.17	1.5	30	1	3,600
AMSD-0018	0.18	1.5	30	1	3,600
AMSD-0019	0.19	1.5	30	1	3,600
AMSD-0020	0.2	2	30	1	2,970
AMSD-0021	0.21	2	30	1	2,970
AMSD-0022	0.22	2	30	1	2,970
AMSD-0023	0.23	2	30	1	2,970
AMSD-0024	0.24	2	30	1	2,970
AMSD-0025	0.25	2.5	30	1	2,970
AMSD-0026	0.26	2.5	30	1	2,970
AMSD-0027	0.27	2.5	30	1	2,970
AMSD-0028	0.28	2.5	30	1	2,970
AMSD-0029	0.29	2.5	30	1	2,970
AMSD-0030	0.3	3	30	1	2,340

型番 CODE NUMBER	径 φD	刃長 ℓ	全長 L	シャンク d	定価 ¥
AMSD-0031	0.31	3	30	1	2,790
AMSD-0032	0.32	3	30	1	2,790
AMSD-0033	0.33	3	30	1	2,790
AMSD-0034	0.34	3	30	1	2,790
AMSD-0035	0.35	3.5	30	1	2,790
AMSD-0036	0.36	3.5	30	1	2,790
AMSD-0037	0.37	3.5	30	1	2,790
AMSD-0038	0.38	3.5	30	1	2,790
AMSD-0039	0.39	3.5	30	1	2,790
AMSD-0040	0.4	4	30	1	2,340
AMSD-0041	0.41	4	30	1	2,790
AMSD-0042	0.42	4	30	1	2,790
AMSD-0043	0.43	4	30	1	2,790
AMSD-0044	0.44	4	30	1	2,790
AMSD-0045	0.45	4.5	30	1	2,790
AMSD-0046	0.46	4.5	30	1	2,790
AMSD-0047	0.47	4.5	30	1	2,790
AMSD-0048	0.48	4.5	30	1	2,790
AMSD-0049	0.49	4.5	30	1	2,790
AMSD-0050	0.5	5	30	1	2,220
AMSD-0051	0.51	5	30	1	2,670
AMSD-0052	0.52	5	30	1	2,670
AMSD-0053	0.53	5	30	1	2,670
AMSD-0054	0.54	5	30	1	2,670
AMSD-0055	0.55	5.5	30	1	2,670
AMSD-0056	0.56	5.5	30	1	2,670

Next Page ▶







# 標準ソリッドドリル 〈ストレートシャンク〉

Solid Drill Standard, Straight Shank

## ADS

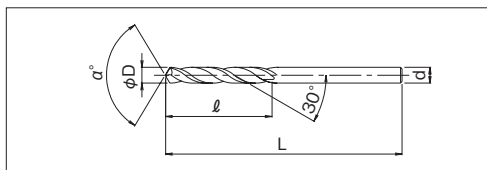

- 鋼材・非鉄、樹脂にいたるまで幅広い対応が可能な高品位汎用ドリルです。  
High quality general purpose drill applicable for steels, non-ferrous materials and for plastics.
- 高速切削はもちろん、低速切削でも高性能が得られる万能タイプです。  
An excellent cutting performance is obtained at comparatively low speed.

刃径公差：φD Tolerance  
φD0.1とび +0~-0.01  
φD0.01とび+0~-0.005

φD ≥ 2.1

超硬  
CARBIDE

118°

135°

ネジレ  
30°

D=d

単位 Unit : mm

型番 CODE NUMBER	径 φD	刃長 ℓ	全長 L	定価 ¥
ADS-0030	0.3	4	30	2,590
ADS-0031	0.31	4	30	3,100
ADS-0032	0.32	4	30	3,100
ADS-0033	0.33	4	30	3,100
ADS-0034	0.34	4	30	3,100
ADS-0035	0.35	4	30	3,100
ADS-0036	0.36	4	30	3,100
ADS-0037	0.37	4	30	3,100
ADS-0038	0.38	4	30	3,100
ADS-0039	0.39	4	30	3,100
ADS-0040	0.4	5	30	2,340
ADS-0041	0.41	5	30	2,800
ADS-0042	0.42	5	30	2,800
ADS-0043	0.43	5	30	2,800
ADS-0044	0.44	5	30	2,800
ADS-0045	0.45	5	30	2,800
ADS-0046	0.46	5	30	2,800
ADS-0047	0.47	5	30	2,800
ADS-0048	0.48	5	30	2,800
ADS-0049	0.49	5	30	2,800
ADS-0050	0.5	6	30	1,920
ADS-0051	0.51	6	30	2,300
ADS-0052	0.52	6	30	2,300
ADS-0053	0.53	6	30	2,300
ADS-0054	0.54	6	30	2,300
ADS-0055	0.55	6	30	2,300

型番 CODE NUMBER	径 φD	刃長 ℓ	全長 L	定価 ¥
ADS-0056	0.56	6	30	2,300
ADS-0057	0.57	6	30	2,300
ADS-0058	0.58	6	30	2,300
ADS-0059	0.59	6	30	2,300
ADS-0060	0.6	6	30	1,920
ADS-0061	0.61	6	30	2,300
ADS-0062	0.62	6	30	2,300
ADS-0063	0.63	6	30	2,300
ADS-0064	0.64	6	30	2,300
ADS-0065	0.65	6	30	2,300
ADS-0066	0.66	6	30	2,300
ADS-0067	0.67	6	30	2,300
ADS-0068	0.68	6	30	2,300
ADS-0069	0.69	6	30	2,300
ADS-0070	0.7	12	40	1,920
ADS-0071	0.71	12	40	2,300
ADS-0072	0.72	12	40	2,300
ADS-0073	0.73	12	40	2,300
ADS-0074	0.74	12	40	2,300
ADS-0075	0.75	12	40	2,300
ADS-0076	0.76	12	40	2,300
ADS-0077	0.77	12	40	2,300
ADS-0078	0.78	12	40	2,300
ADS-0079	0.79	12	40	2,300
ADS-0080	0.8	12	40	1,920
ADS-0081	0.81	12	40	2,300

単位 Unit : mm

型番 CODE NUMBER	径 φD	刃長 ℓ	全長 L	定価 ¥
ADS-0082	0.82	12	40	2,300
ADS-0083	0.83	12	40	2,300
ADS-0084	0.84	12	40	2,300
ADS-0085	0.85	12	40	2,300
ADS-0086	0.86	12	40	2,300
ADS-0087	0.87	12	40	2,300
ADS-0088	0.88	12	40	2,300
ADS-0089	0.89	12	40	2,300
ADS-0090	0.9	12	40	1,920
ADS-0091	0.91	12	40	2,300
ADS-0092	0.92	12	40	2,300
ADS-0093	0.93	12	40	2,300
ADS-0094	0.94	12	40	2,300
ADS-0095	0.95	12	40	2,300
ADS-0096	0.96	12	40	2,300
ADS-0097	0.97	12	40	2,300
ADS-0098	0.98	12	40	2,300
ADS-0099	0.99	12	40	2,300
ADS-0100	1	15	40	1,920
ADS-0101	1.01	15	40	2,300
ADS-0102	1.02	15	40	2,300
ADS-0103	1.03	15	40	2,300
ADS-0104	1.04	15	40	2,300
ADS-0105	1.05	15	40	2,300
ADS-0106	1.06	15	40	2,300
ADS-0107	1.07	15	40	2,300
ADS-0108	1.08	15	40	2,300
ADS-0109	1.09	15	40	2,300
ADS-0110	1.1	15	40	1,920
ADS-0111	1.11	15	40	2,300
ADS-0112	1.12	15	40	2,300
ADS-0113	1.13	15	40	2,300
ADS-0114	1.14	15	40	2,300
ADS-0115	1.15	15	40	2,300
ADS-0116	1.16	15	40	2,300
ADS-0117	1.17	15	40	2,300
ADS-0118	1.18	15	40	2,300
ADS-0119	1.19	15	40	2,300
ADS-0120	1.2	15	40	1,920
ADS-0121	1.21	15	40	2,300
ADS-0122	1.22	15	40	2,300
ADS-0123	1.23	15	40	2,300
ADS-0124	1.24	15	40	2,300
ADS-0125	1.25	15	40	2,300

型番 CODE NUMBER	径 φD	刃長 ℓ	全長 L	定価 ¥
ADS-0126	1.26	15	40	2,300
ADS-0127	1.27	15	40	2,300
ADS-0128	1.28	15	40	2,300
ADS-0129	1.29	15	40	2,300
ADS-0130	1.3	16	40	1,920
ADS-0131	1.31	16	40	2,300
ADS-0132	1.32	16	40	2,300
ADS-0133	1.33	16	40	2,300
ADS-0134	1.34	16	40	2,300
ADS-0135	1.35	16	40	2,300
ADS-0136	1.36	16	40	2,300
ADS-0137	1.37	16	40	2,300
ADS-0138	1.38	16	40	2,300
ADS-0139	1.39	16	40	2,300
ADS-0140	1.4	16	40	1,920
ADS-0141	1.41	16	40	2,300
ADS-0142	1.42	16	40	2,300
ADS-0143	1.43	16	40	2,300
ADS-0144	1.44	16	40	2,300
ADS-0145	1.45	16	40	2,300
ADS-0146	1.46	16	40	2,300
ADS-0147	1.47	16	40	2,300
ADS-0148	1.48	16	40	2,300
ADS-0149	1.49	16	40	2,300
ADS-0150	1.5	16	40	1,920
ADS-0151	1.51	16	40	2,700
ADS-0152	1.52	16	40	2,700
ADS-0153	1.53	16	40	2,700
ADS-0154	1.54	16	40	2,700
ADS-0155	1.55	16	40	2,700
ADS-0156	1.56	16	40	2,700
ADS-0157	1.57	16	40	2,700
ADS-0158	1.58	16	40	2,700
ADS-0159	1.59	16	40	2,700
ADS-0160	1.6	18	40	2,250
ADS-0161	1.61	18	40	2,700
ADS-0162	1.62	18	40	2,700
ADS-0163	1.63	18	40	2,700
ADS-0164	1.64	18	40	2,700
ADS-0165	1.65	18	40	2,700
ADS-0166	1.66	18	40	2,700
ADS-0167	1.67	18	40	2,700
ADS-0168	1.68	18	40	2,700
ADS-0169	1.69	18	40	2,700

# ADS 標準ソリッドドリル (ストレートシャンク)

単位 Unit : mm

型番 CODE NUMBER	径 φD	刃長 ℓ	全長 L	定価 ¥
ADS-0170	1.7	18	40	2,250
ADS-0171	1.71	18	40	2,700
ADS-0172	1.72	18	40	2,700
ADS-0173	1.73	18	40	2,700
ADS-0174	1.74	18	40	2,700
ADS-0175	1.75	18	40	2,700
ADS-0176	1.76	18	40	2,700
ADS-0177	1.77	18	40	2,700
ADS-0178	1.78	18	40	2,700
ADS-0179	1.79	18	40	2,700
ADS-0180	1.8	18	40	2,250
ADS-0181	1.81	18	40	2,700
ADS-0182	1.82	18	40	2,700
ADS-0183	1.83	18	40	2,700
ADS-0184	1.84	18	40	2,700
ADS-0185	1.85	18	40	2,700
ADS-0186	1.86	18	40	2,700
ADS-0187	1.87	18	40	2,700
ADS-0188	1.88	18	40	2,700
ADS-0189	1.89	18	40	2,700
ADS-0190	1.9	18	40	2,250
ADS-0191	1.91	18	40	2,700
ADS-0192	1.92	18	40	2,700
ADS-0193	1.93	18	40	2,700
ADS-0194	1.94	18	40	2,700
ADS-0195	1.95	18	40	2,700
ADS-0196	1.96	18	40	2,700
ADS-0197	1.97	18	40	2,700
ADS-0198	1.98	18	40	2,700
ADS-0199	1.99	18	40	2,700
ADS-0200	2	18	40	2,250
ADS-0201	2.01	18	40	2,900
ADS-0202	2.02	18	40	2,900
ADS-0203	2.03	18	40	2,900
ADS-0204	2.04	18	40	2,900
ADS-0205	2.05	18	40	2,900
ADS-0206	2.06	18	40	2,900
ADS-0207	2.07	18	40	2,900
ADS-0208	2.08	18	40	2,900
ADS-0209	2.09	18	40	2,900
ADS-0210	2.1	20	40 (45)	2,420
ADS-0211	2.11	20	40 (45)	2,900
ADS-0212	2.12	20	40 (45)	2,900
ADS-0213	2.13	20	40 (45)	2,900

型番 CODE NUMBER	径 φD	刃長 ℓ	全長 L	定価 ¥
ADS-0214	2.14	20	40 (45)	2,900
ADS-0215	2.15	20	40 (45)	2,900
ADS-0216	2.16	20	40 (45)	2,900
ADS-0217	2.17	20	40 (45)	2,900
ADS-0218	2.18	20	40 (45)	2,900
ADS-0219	2.19	20	40 (45)	2,900
ADS-0220	2.2	20	40 (45)	2,420
ADS-0221	2.21	20	40 (45)	2,900
ADS-0222	2.22	20	40 (45)	2,900
ADS-0223	2.23	20	40 (45)	2,900
ADS-0224	2.24	20	40 (45)	2,900
ADS-0225	2.25	20	40 (45)	2,900
ADS-0226	2.26	20	40 (45)	2,900
ADS-0227	2.27	20	40 (45)	2,900
ADS-0228	2.28	20	40 (45)	2,900
ADS-0229	2.29	20	40 (45)	2,900
ADS-0230	2.3	20	40 (45)	2,420
ADS-0231	2.31	20	40 (45)	2,900
ADS-0232	2.32	20	40 (45)	2,900
ADS-0233	2.33	20	40 (45)	2,900
ADS-0234	2.34	20	40 (45)	2,900
ADS-0235	2.35	20	40 (45)	2,900
ADS-0236	2.36	20	40 (45)	2,900
ADS-0237	2.37	20	40 (45)	2,900
ADS-0238	2.38	20	40 (45)	2,900
ADS-0239	2.39	20	40 (45)	2,900
ADS-0240	2.4	20	40 (45)	2,420
ADS-0241	2.41	20	40 (45)	2,900
ADS-0242	2.42	20	40 (45)	2,900
ADS-0243	2.43	20	40 (45)	2,900
ADS-0244	2.44	20	40 (45)	2,900
ADS-0245	2.45	20	40 (45)	2,900
ADS-0246	2.46	20	40 (45)	2,900
ADS-0247	2.47	20	40 (45)	2,900
ADS-0248	2.48	20	40 (45)	2,900
ADS-0249	2.49	20	40 (45)	2,900
ADS-0250	2.5	20	40 (45)	2,420
ADS-0251	2.51	20	40 (45)	3,500
ADS-0252	2.52	20	40 (45)	3,500
ADS-0253	2.53	20	40 (45)	3,500
ADS-0254	2.54	20	40 (45)	3,500
ADS-0255	2.55	20	40 (45)	3,500
ADS-0256	2.56	20	40 (45)	3,500
ADS-0257	2.57	20	40 (45)	3,500

\*全長は ( ) 内表示寸法に順次変更します。

単位 Unit : mm

型番 CODE NUMBER	径 φD	刃長 ℓ	全長 L	定価 ¥
ADS-0258	2.58	20	40 (45)	3,500
ADS-0259	2.59	20	40 (45)	3,500
ADS-0260	2.6	20	45	2,920
ADS-0261	2.61	20	45	3,500
ADS-0262	2.62	20	45	3,500
ADS-0263	2.63	20	45	3,500
ADS-0264	2.64	20	45	3,500
ADS-0265	2.65	20	45	3,500
ADS-0266	2.66	20	45	3,500
ADS-0267	2.67	20	45	3,500
ADS-0268	2.68	20	45	3,500
ADS-0269	2.69	20	45	3,500
ADS-0270	2.7	20	45	2,920
ADS-0271	2.71	20	45	3,500
ADS-0272	2.72	20	45	3,500
ADS-0273	2.73	20	45	3,500
ADS-0274	2.74	20	45	3,500
ADS-0275	2.75	20	45	3,500
ADS-0276	2.76	20	45	3,500
ADS-0277	2.77	20	45	3,500
ADS-0278	2.78	20	45	3,500
ADS-0279	2.79	20	45	3,500
ADS-0280	2.8	20	45	2,920
ADS-0281	2.81	20	45	3,500
ADS-0282	2.82	20	45	3,500
ADS-0283	2.83	20	45	3,500
ADS-0284	2.84	20	45	3,500
ADS-0285	2.85	20	45	3,500
ADS-0286	2.86	20	45	3,500
ADS-0287	2.87	20	45	3,500
ADS-0288	2.88	20	45	3,500
ADS-0289	2.89	20	45	3,500
ADS-0290	2.9	20	45	2,920
ADS-0291	2.91	20	45	3,500
ADS-0292	2.92	20	45	3,500
ADS-0293	2.93	20	45	3,500
ADS-0294	2.94	20	45	3,500
ADS-0295	2.95	20	45	3,500
ADS-0296	2.96	20	45	3,500
ADS-0297	2.97	20	45	3,500
ADS-0298	2.98	20	45	3,500
ADS-0299	2.99	20	45	3,500
ADS-0300	3	20	45	2,920
ADS-0301	3.01	20	45	4,400

型番 CODE NUMBER	径 φD	刃長 ℓ	全長 L	定価 ¥
ADS-0302	3.02	20	45	4,400
ADS-0303	3.03	20	45	4,400
ADS-0304	3.04	20	45	4,400
ADS-0305	3.05	20	45	4,400
ADS-0306	3.06	20	45	4,400
ADS-0307	3.07	20	45	4,400
ADS-0308	3.08	20	45	4,400
ADS-0309	3.09	20	45	4,400
ADS-0310	3.1	25	50	3,670
ADS-0311	3.11	25	50	4,400
ADS-0312	3.12	25	50	4,400
ADS-0313	3.13	25	50	4,400
ADS-0314	3.14	25	50	4,400
ADS-0315	3.15	25	50	4,400
ADS-0316	3.16	25	50	4,400
ADS-0317	3.17	25	50	4,400
ADS-0318	3.18	25	50	4,400
ADS-0319	3.19	25	50	4,400
ADS-0320	3.2	25	50	3,670
ADS-0321	3.21	25	50	4,400
ADS-0322	3.22	25	50	4,400
ADS-0323	3.23	25	50	4,400
ADS-0324	3.24	25	50	4,400
ADS-0325	3.25	25	50	4,400
ADS-0326	3.26	25	50	4,400
ADS-0327	3.27	25	50	4,400
ADS-0328	3.28	25	50	4,400
ADS-0329	3.29	25	50	4,400
ADS-0330	3.3	25	50	3,670
ADS-0331	3.31	25	50	4,400
ADS-0332	3.32	25	50	4,400
ADS-0333	3.33	25	50	4,400
ADS-0334	3.34	25	50	4,400
ADS-0335	3.35	25	50	4,400
ADS-0336	3.36	25	50	4,400
ADS-0337	3.37	25	50	4,400
ADS-0338	3.38	25	50	4,400
ADS-0339	3.39	25	50	4,400
ADS-0340	3.4	25	50	3,670
ADS-0341	3.41	25	50	4,400
ADS-0342	3.42	25	50	4,400
ADS-0343	3.43	25	50	4,400
ADS-0344	3.44	25	50	4,400
ADS-0345	3.45	25	50	4,400

※全長は ( ) 内表示寸法に順次変更します。

Next Page ▶

型番 CODE NUMBER	径 φD	刃長 ℓ	全長 L	定価 ¥
ADS-0346	3.46	25	50	4,400
ADS-0347	3.47	25	50	4,400
ADS-0348	3.48	25	50	4,400
ADS-0349	3.49	25	50	4,400
ADS-0350	3.5	25	50	3,670
ADS-0351	3.51	25	50	5,600
ADS-0352	3.52	25	50	5,600
ADS-0353	3.53	25	50	5,600
ADS-0354	3.54	25	50	5,600
ADS-0355	3.55	25	50	5,600
ADS-0356	3.56	25	50	5,600
ADS-0357	3.57	25	50	5,600
ADS-0358	3.58	25	50	5,600
ADS-0359	3.59	25	50	5,600
ADS-0360	3.6	27	55	4,670
ADS-0361	3.61	27	55	5,600
ADS-0362	3.62	27	55	5,600
ADS-0363	3.63	27	55	5,600
ADS-0364	3.64	27	55	5,600
ADS-0365	3.65	27	55	5,600
ADS-0366	3.66	27	55	5,600
ADS-0367	3.67	27	55	5,600
ADS-0368	3.68	27	55	5,600
ADS-0369	3.69	27	55	5,600
ADS-0370	3.7	27	55	4,670
ADS-0371	3.71	27	55	5,600
ADS-0372	3.72	27	55	5,600
ADS-0373	3.73	27	55	5,600
ADS-0374	3.74	27	55	5,600
ADS-0375	3.75	27	55	5,600
ADS-0376	3.76	27	55	5,600
ADS-0377	3.77	27	55	5,600
ADS-0378	3.78	27	55	5,600
ADS-0379	3.79	27	55	5,600
ADS-0380	3.8	27	55	4,670
ADS-0381	3.81	27	55	5,600
ADS-0382	3.82	27	55	5,600
ADS-0383	3.83	27	55	5,600
ADS-0384	3.84	27	55	5,600
ADS-0385	3.85	27	55	5,600
ADS-0386	3.86	27	55	5,600
ADS-0387	3.87	27	55	5,600
ADS-0388	3.88	27	55	5,600
ADS-0389	3.89	27	55	5,600

型番 CODE NUMBER	径 φD	刃長 ℓ	全長 L	定価 ¥
ADS-0390	3.9	27	55	4,670
ADS-0391	3.91	27	55	5,600
ADS-0392	3.92	27	55	5,600
ADS-0393	3.93	27	55	5,600
ADS-0394	3.94	27	55	5,600
ADS-0395	3.95	27	55	5,600
ADS-0396	3.96	27	55	5,600
ADS-0397	3.97	27	55	5,600
ADS-0398	3.98	27	55	5,600
ADS-0399	3.99	27	55	5,600
ADS-0400	4	27	55	4,670
ADS-0401	4.01	27	55	6,500
ADS-0402	4.02	27	55	6,500
ADS-0403	4.03	27	55	6,500
ADS-0404	4.04	27	55	6,500
ADS-0405	4.05	27	55	6,500
ADS-0406	4.06	27	55	6,500
ADS-0407	4.07	27	55	6,500
ADS-0408	4.08	27	55	6,500
ADS-0409	4.09	27	55	6,500
ADS-0410	4.1	30	60	5,420
ADS-0411	4.11	30	60	6,500
ADS-0412	4.12	30	60	6,500
ADS-0413	4.13	30	60	6,500
ADS-0414	4.14	30	60	6,500
ADS-0415	4.15	30	60	6,500
ADS-0416	4.16	30	60	6,500
ADS-0417	4.17	30	60	6,500
ADS-0418	4.18	30	60	6,500
ADS-0419	4.19	30	60	6,500
ADS-0420	4.2	30	60	5,420
ADS-0421	4.21	30	60	6,500
ADS-0422	4.22	30	60	6,500
ADS-0423	4.23	30	60	6,500
ADS-0424	4.24	30	60	6,500
ADS-0425	4.25	30	60	6,500
ADS-0426	4.26	30	60	6,500
ADS-0427	4.27	30	60	6,500
ADS-0428	4.28	30	60	6,500
ADS-0429	4.29	30	60	6,500
ADS-0430	4.3	30	60	5,420
ADS-0431	4.31	30	60	6,500
ADS-0432	4.32	30	60	6,500
ADS-0433	4.33	30	60	6,500

単位 Unit : mm

型番 CODE NUMBER	径 φD	刃長 ℓ	全長 L	定価 ¥
ADS-0434	4.34	30	60	6,500
ADS-0435	4.35	30	60	6,500
ADS-0436	4.36	30	60	6,500
ADS-0437	4.37	30	60	6,500
ADS-0438	4.38	30	60	6,500
ADS-0439	4.39	30	60	6,500
ADS-0440	4.4	30	60	5,420
ADS-0441	4.41	30	60	6,500
ADS-0442	4.42	30	60	6,500
ADS-0443	4.43	30	60	6,500
ADS-0444	4.44	30	60	6,500
ADS-0445	4.45	30	60	6,500
ADS-0446	4.46	30	60	6,500
ADS-0447	4.47	30	60	6,500
ADS-0448	4.48	30	60	6,500
ADS-0449	4.49	30	60	6,500
ADS-0450	4.5	30	60	5,420
ADS-0451	4.51	30	60	7,400
ADS-0452	4.52	30	60	7,400
ADS-0453	4.53	30	60	7,400
ADS-0454	4.54	30	60	7,400
ADS-0455	4.55	30	60	7,400
ADS-0456	4.56	30	60	7,400
ADS-0457	4.57	30	60	7,400
ADS-0458	4.58	30	60	7,400
ADS-0459	4.59	30	60	7,400
ADS-0460	4.6	30	60	6,170
ADS-0461	4.61	30	60	7,400
ADS-0462	4.62	30	60	7,400
ADS-0463	4.63	30	60	7,400
ADS-0464	4.64	30	60	7,400
ADS-0465	4.65	30	60	7,400
ADS-0466	4.66	30	60	7,400
ADS-0467	4.67	30	60	7,400
ADS-0468	4.68	30	60	7,400
ADS-0469	4.69	30	60	7,400
ADS-0470	4.7	30	60	6,170
ADS-0471	4.71	30	60	7,400
ADS-0472	4.72	30	60	7,400
ADS-0473	4.73	30	60	7,400
ADS-0474	4.74	30	60	7,400
ADS-0475	4.75	30	60	7,400
ADS-0476	4.76	30	60	7,400
ADS-0477	4.77	30	60	7,400

型番 CODE NUMBER	径 φD	刃長 ℓ	全長 L	定価 ¥
ADS-0478	4.78	30	60	7,400
ADS-0479	4.79	30	60	7,400
ADS-0480	4.8	30	60	6,170
ADS-0481	4.81	30	60	7,400
ADS-0482	4.82	30	60	7,400
ADS-0483	4.83	30	60	7,400
ADS-0484	4.84	30	60	7,400
ADS-0485	4.85	30	60	7,400
ADS-0486	4.86	30	60	7,400
ADS-0487	4.87	30	60	7,400
ADS-0488	4.88	30	60	7,400
ADS-0489	4.89	30	60	7,400
ADS-0490	4.9	30	60	6,170
ADS-0491	4.91	30	60	7,400
ADS-0492	4.92	30	60	7,400
ADS-0493	4.93	30	60	7,400
ADS-0494	4.94	30	60	7,400
ADS-0495	4.95	30	60	7,400
ADS-0496	4.96	30	60	7,400
ADS-0497	4.97	30	60	7,400
ADS-0498	4.98	30	60	7,400
ADS-0499	4.99	30	60	7,400
ADS-0500	5	30	60	6,170
ADS-0501	5.01	30	60	8,600
ADS-0502	5.02	30	60	8,600
ADS-0503	5.03	30	60	8,600
ADS-0504	5.04	30	60	8,600
ADS-0505	5.05	30	60	8,600
ADS-0506	5.06	30	60	8,600
ADS-0507	5.07	30	60	8,600
ADS-0508	5.08	30	60	8,600
ADS-0509	5.09	30	60	8,600
ADS-0510	5.1	40	65 (80)	7,170
ADS-0511	5.11	40	65 (80)	8,600
ADS-0512	5.12	40	65 (80)	8,600
ADS-0513	5.13	40	65 (80)	8,600
ADS-0514	5.14	40	65 (80)	8,600
ADS-0515	5.15	40	65 (80)	8,600
ADS-0516	5.16	40	65 (80)	8,600
ADS-0517	5.17	40	65 (80)	8,600
ADS-0518	5.18	40	65 (80)	8,600
ADS-0519	5.19	40	65 (80)	8,600
ADS-0520	5.2	40	65 (80)	7,170
ADS-0521	5.21	40	65 (80)	8,600

※全長は（ ）内表示寸法に順次変更します。

Next Page ▶

# ADS 標準ソリッドドリル (ストレートシャンク)

単位 Unit : mm

型番 CODE NUMBER	径 φD	刃長 ℓ	全長 L	定価 ¥
ADS-0522	5.22	40	65 (80)	8,600
ADS-0523	5.23	40	65 (80)	8,600
ADS-0524	5.24	40	65 (80)	8,600
ADS-0525	5.25	40	65 (80)	8,600
ADS-0526	5.26	40	65 (80)	8,600
ADS-0527	5.27	40	65 (80)	8,600
ADS-0528	5.28	40	65 (80)	8,600
ADS-0529	5.29	40	65 (80)	8,600
ADS-0530	5.3	40	65 (80)	7,170
ADS-0531	5.31	40	65 (80)	8,600
ADS-0532	5.32	40	65 (80)	8,600
ADS-0533	5.33	40	65 (80)	8,600
ADS-0534	5.34	40	65 (80)	8,600
ADS-0535	5.35	40	65 (80)	8,600
ADS-0536	5.36	40	65 (80)	8,600
ADS-0537	5.37	40	65 (80)	8,600
ADS-0538	5.38	40	65 (80)	8,600
ADS-0539	5.39	40	65 (80)	8,600
ADS-0540	5.4	40	65 (80)	7,170
ADS-0541	5.41	40	65 (80)	8,600
ADS-0542	5.42	40	65 (80)	8,600
ADS-0543	5.43	40	65 (80)	8,600
ADS-0544	5.44	40	65 (80)	8,600
ADS-0545	5.45	40	65 (80)	8,600
ADS-0546	5.46	40	65 (80)	8,600
ADS-0547	5.47	40	65 (80)	8,600
ADS-0548	5.48	40	65 (80)	8,600
ADS-0549	5.49	40	65 (80)	8,600
ADS-0550	5.5	40	65 (80)	7,170
ADS-0551	5.51	40	65 (80)	9,600
ADS-0552	5.52	40	65 (80)	9,600
ADS-0553	5.53	40	65 (80)	9,600
ADS-0554	5.54	40	65 (80)	9,600
ADS-0555	5.55	40	65 (80)	9,600
ADS-0556	5.56	40	65 (80)	9,600
ADS-0557	5.57	40	65 (80)	9,600
ADS-0558	5.58	40	65 (80)	9,600
ADS-0559	5.59	40	65 (80)	9,600
ADS-0560	5.6	40	65 (80)	8,000
ADS-0561	5.61	40	65 (80)	9,600
ADS-0562	5.62	40	65 (80)	9,600
ADS-0563	5.63	40	65 (80)	9,600
ADS-0564	5.64	40	65 (80)	9,600
ADS-0565	5.65	40	65 (80)	9,600

型番 CODE NUMBER	径 φD	刃長 ℓ	全長 L	定価 ¥
ADS-0566	5.66	40	65 (80)	9,600
ADS-0567	5.67	40	65 (80)	9,600
ADS-0568	5.68	40	65 (80)	9,600
ADS-0569	5.69	40	65 (80)	9,600
ADS-0570	5.7	40	65 (80)	8,000
ADS-0571	5.71	40	65 (80)	9,600
ADS-0572	5.72	40	65 (80)	9,600
ADS-0573	5.73	40	65 (80)	9,600
ADS-0574	5.74	40	65 (80)	9,600
ADS-0575	5.75	40	65 (80)	9,600
ADS-0576	5.76	40	65 (80)	9,600
ADS-0577	5.77	40	65 (80)	9,600
ADS-0578	5.78	40	65 (80)	9,600
ADS-0579	5.79	40	65 (80)	9,600
ADS-0580	5.8	40	65 (80)	8,000
ADS-0581	5.81	40	65 (80)	9,600
ADS-0582	5.82	40	65 (80)	9,600
ADS-0583	5.83	40	65 (80)	9,600
ADS-0584	5.84	40	65 (80)	9,600
ADS-0585	5.85	40	65 (80)	9,600
ADS-0586	5.86	40	65 (80)	9,600
ADS-0587	5.87	40	65 (80)	9,600
ADS-0588	5.88	40	65 (80)	9,600
ADS-0589	5.89	40	65 (80)	9,600
ADS-0590	5.9	40	65 (80)	8,000
ADS-0591	5.91	40	65 (80)	9,600
ADS-0592	5.92	40	65 (80)	9,600
ADS-0593	5.93	40	65 (80)	9,600
ADS-0594	5.94	40	65 (80)	9,600
ADS-0595	5.95	40	65 (80)	9,600
ADS-0596	5.96	40	65 (80)	9,600
ADS-0597	5.97	40	65 (80)	9,600
ADS-0598	5.98	40	65 (80)	9,600
ADS-0599	5.99	40	65 (80)	9,600
ADS-0600	6	40	65 (80)	8,000
ADS-0601	6.01	40	65 (80)	11,500
ADS-0602	6.02	40	65 (80)	11,500
ADS-0603	6.03	40	65 (80)	11,500
ADS-0604	6.04	40	65 (80)	11,500
ADS-0605	6.05	40	65 (80)	11,500
ADS-0606	6.06	40	65 (80)	11,500
ADS-0607	6.07	40	65 (80)	11,500
ADS-0608	6.08	40	65 (80)	11,500
ADS-0609	6.09	40	65 (80)	11,500

※全長は ( ) 内表示寸法に順次変更します。



単位 Unit : mm

型番 CODE NUMBER	径 φD	刃長 ℓ	全長 L	定価 ¥
ADS-0610	6.1	40	65 (80)	10,350
ADS-0615	6.15	40	65 (80)	13,400
ADS-0620	6.2	40	65 (80)	10,350
ADS-0625	6.25	40	65 (80)	13,400
ADS-0630	6.3	40	65 (80)	10,350
ADS-0635	6.35	40	65 (80)	13,400
ADS-0640	6.4	40	65 (80)	10,350
ADS-0645	6.45	40	65 (80)	13,400
ADS-0650	6.5	40	65 (80)	10,750
ADS-0655	6.55	40	65 (80)	15,200
ADS-0660	6.6	40	65 (80)	10,750
ADS-0665	6.65	40	65 (80)	15,200
ADS-0670	6.7	40	65 (80)	10,750
ADS-0675	6.75	40	65 (80)	15,200
ADS-0680	6.8	40	65 (80)	10,750
ADS-0685	6.85	40	65 (80)	15,200
ADS-0690	6.9	40	65 (80)	10,750
ADS-0695	6.95	40	65 (80)	15,200
ADS-0700	7	40	65 (80)	11,900
ADS-0701	7.01	40	65 (80)	15,100
ADS-0702	7.02	40	65 (80)	15,100
ADS-0703	7.03	40	65 (80)	15,100
ADS-0704	7.04	40	65 (80)	15,100
ADS-0705	7.05	40	65 (80)	15,100
ADS-0706	7.06	40	65 (80)	15,100
ADS-0707	7.07	40	65 (80)	15,100
ADS-0708	7.08	40	65 (80)	15,100
ADS-0709	7.09	40	65 (80)	15,100
ADS-0710	7.1	40	80	12,100
ADS-0720	7.2	40	80	12,100
ADS-0730	7.3	40	80	12,100
ADS-0740	7.4	40	80	12,100
ADS-0750	7.5	40	80	13,800
ADS-0760	7.6	40	80	13,800
ADS-0770	7.7	40	80	13,800
ADS-0780	7.8	40	80	13,800
ADS-0790	7.9	40	80	13,800
ADS-0800	8	40	80	13,000
ADS-0801	8.01	40	80	21,400
ADS-0802	8.02	40	80	21,400
ADS-0803	8.03	40	80	21,400
ADS-0804	8.04	40	80	21,400
ADS-0805	8.05	40	80	21,400
ADS-0806	8.06	40	80	21,400

型番 CODE NUMBER	径 φD	刃長 ℓ	全長 L	定価 ¥
ADS-0807	8.07	40	80	21,400
ADS-0808	8.08	40	80	21,400
ADS-0809	8.09	40	80	21,400
ADS-0810	8.1	40	80	14,200
ADS-0820	8.2	40	80	14,200
ADS-0830	8.3	40	80	14,200
ADS-0840	8.4	40	80	14,200
ADS-0850	8.5	40	80	17,900
ADS-0860	8.6	40	80	17,900
ADS-0870	8.7	40	80	17,900
ADS-0880	8.8	40	80	17,900
ADS-0890	8.9	40	80	17,900
ADS-0900	9	40	80	19,180
ADS-0901	9.01	40	80	24,200
ADS-0902	9.02	40	80	24,200
ADS-0903	9.03	40	80	24,200
ADS-0904	9.04	40	80	24,200
ADS-0905	9.05	40	80	24,200
ADS-0906	9.06	40	80	24,200
ADS-0907	9.07	40	80	24,200
ADS-0908	9.08	40	80	24,200
ADS-0909	9.09	40	80	24,200
ADS-0910	9.1	40	80	19,500
ADS-0920	9.2	40	80	19,500
ADS-0930	9.3	40	80	19,500
ADS-0940	9.4	40	80	19,500
ADS-0950	9.5	40	80	23,400
ADS-0960	9.6	50	100	24,200
ADS-0970	9.7	50	100	24,200
ADS-0980	9.8	50	100	24,200
ADS-0990	9.9	50	100	24,200
ADS-1000	10	50	100	30,500
ADS-1001	10.01	50	100	38,500
ADS-1002	10.02	50	100	38,500
ADS-1003	10.03	50	100	38,500
ADS-1004	10.04	50	100	38,500
ADS-1005	10.05	50	100	38,500
ADS-1006	10.06	50	100	38,500
ADS-1007	10.07	50	100	38,500
ADS-1008	10.08	50	100	38,500
ADS-1009	10.09	50	100	38,500
ADS-1010	10.1	50	100	32,500
ADS-1020	10.2	50	100	32,500
ADS-1030	10.3	50	100	32,500

※全長は( )内表示寸法に順次変更します。

Next Page ▶



## ソリッド セミロングドリル 〈ストレートシャンク〉

Semi Long Drill, Straight Shank

ADSL

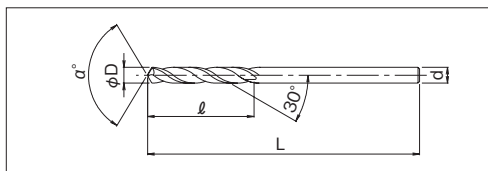

- 鋼材・非鉄、樹脂にいたるまで幅広い対応が可能な高品質汎用ドリルです。  
High quality general purpose drill applicable for steels, non-ferrous materials and for plastics.
- 高速切削はもちろん、低速切削でも高性能が得られる万能タイプです。  
An excellent cutting performance is obtained at comparatively low speed.

刃径公差：+0~-0.01  
φD Tolerance

型番 CODE NUMBER	径 φD	刃長 ℓ	全長 L	定価 ¥
ADSL-0030	0.3	8	40	2,620
ADSL-0035	0.35	8	40	3,150
ADSL-0040	0.4	8	40	2,620
ADSL-0045	0.45	8	40	3,150
ADSL-0050	0.5	8	40	2,220
ADSL-0055	0.55	8	40	2,670
ADSL-0060	0.6	8	40	2,170
ADSL-0065	0.65	8	40	2,600
ADSL-0070	0.7	15	50	2,170
ADSL-0075	0.75	15	50	2,600
ADSL-0080	0.8	15	50	2,170
ADSL-0085	0.85	15	50	2,600
ADSL-0090	0.9	15	50	2,170
ADSL-0095	0.95	15	50	2,730
ADSL-0100	1	16	50	2,270
ADSL-0105	1.05	16	50	2,730
ADSL-0110	1.1	16	50	2,270
ADSL-0115	1.15	16	50	2,730
ADSL-0120	1.2	18	50	2,270
ADSL-0125	1.25	18	50	2,730
ADSL-0130	1.3	18	50	2,270
ADSL-0135	1.35	18	50	2,730
ADSL-0140	1.4	18	50	2,270
ADSL-0145	1.45	18	50	2,730
ADSL-0150	1.5	24	50	2,270
ADSL-0155	1.55	24	50	3,070

※全長は（ ）内表示寸法に順次変更します。

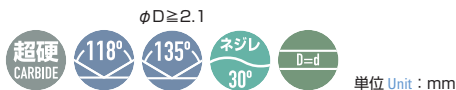

型番 CODE NUMBER	径 φD	刃長 ℓ	全長 L	定価 ¥
ADSL-0160	1.6	24	55	2,550
ADSL-0165	1.65	24	55	3,070
ADSL-0170	1.7	24	55	2,550
ADSL-0175	1.75	24	55	3,070
ADSL-0180	1.8	24	55	2,550
ADSL-0185	1.85	24	55	3,070
ADSL-0190	1.9	24	55	2,550
ADSL-0195	1.95	24	55	3,280
ADSL-0200	2	24	55	2,730
ADSL-0205	2.05	24	55	3,280
ADSL-0210	2.1	24	55	2,730
ADSL-0215	2.15	24	55	3,280
ADSL-0220	2.2	26	58 (65)	2,730
ADSL-0225	2.25	26	58 (65)	3,280
ADSL-0230	2.3	26	58 (65)	2,730
ADSL-0235	2.35	26	58 (65)	3,450
ADSL-0240	2.4	26	61 (65)	2,870
ADSL-0245	2.45	26	61 (65)	3,450
ADSL-0250	2.5	26	61 (65)	2,870
ADSL-0255	2.55	26	61 (65)	3,980
ADSL-0260	2.6	28	64 (65)	3,320
ADSL-0265	2.65	28	64 (65)	3,980
ADSL-0270	2.7	28	64 (65)	3,320
ADSL-0275	2.75	28	64 (65)	3,980
ADSL-0280	2.8	30	67 (75)	3,320
ADSL-0285	2.85	30	67 (75)	3,980

Next Page ▶

# ADSL ソリッド セミロングドリル (ストレートシャンク)

単位 Unit : mm

型番 CODE NUMBER	径 φD	刃長 ℓ	全長 L	定価 ¥
ADSL-0290	2.9	30	71 (75)	3,320
ADSL-0295	2.95	30	71 (75)	3,980
ADSL-0300	3	30	71 (75)	3,320
ADSL-0305	3.05	30	71 (75)	5,030
ADSL-0310	3.1	32	71 (75)	4,180
ADSL-0315	3.15	32	71 (75)	5,030
ADSL-0320	3.2	32	71 (75)	4,180
ADSL-0325	3.25	32	71 (75)	5,030
ADSL-0330	3.3	35	73 (75)	4,180
ADSL-0335	3.35	35	73 (75)	5,030
ADSL-0340	3.4	35	73 (75)	4,180
ADSL-0345	3.45	35	73 (75)	5,030
ADSL-0350	3.5	35	73 (75)	4,180
ADSL-0355	3.55	35	73 (75)	6,380
ADSL-0360	3.6	37	76 (80)	5,320
ADSL-0365	3.65	37	76 (80)	6,380
ADSL-0370	3.7	37	76 (80)	5,320
ADSL-0375	3.75	37	76 (80)	6,380
ADSL-0380	3.8	37	76 (80)	5,320
ADSL-0385	3.85	37	76 (80)	6,380
ADSL-0390	3.9	37	79 (80)	5,320
ADSL-0395	3.95	37	79 (80)	6,380
ADSL-0400	4	40	83 (90)	5,320
ADSL-0405	4.05	40	83 (90)	6,500
ADSL-0410	4.1	40	83 (90)	5,420
ADSL-0415	4.15	40	83 (90)	7,400
ADSL-0420	4.2	40	83 (90)	6,170
ADSL-0425	4.25	40	83 (90)	7,400
ADSL-0430	4.3	40	83 (90)	6,170
ADSL-0435	4.35	40	83 (90)	7,400
ADSL-0440	4.4	42	86 (90)	6,170
ADSL-0445	4.45	42	86 (90)	7,400
ADSL-0450	4.5	42	86 (90)	6,170
ADSL-0455	4.55	42	86 (90)	8,470
ADSL-0460	4.6	42	86 (90)	7,050
ADSL-0465	4.65	42	86 (90)	8,470
ADSL-0470	4.7	42	89 (90)	7,050
ADSL-0475	4.75	42	89 (90)	8,470
ADSL-0480	4.8	42	89 (90)	7,050
ADSL-0485	4.85	42	89 (90)	8,470
ADSL-0490	4.9	45	92 (100)	7,050
ADSL-0495	4.95	45	92 (100)	8,470
ADSL-0500	5	45	92 (100)	7,050
ADSL-0505	5.05	45	92 (100)	10,080

型番 CODE NUMBER	径 φD	刃長 ℓ	全長 L	定価 ¥
ADSL-0510	5.1	45	92 (100)	8,400
ADSL-0515	5.15	45	92 (100)	10,080
ADSL-0520	5.2	45	95 (100)	8,400
ADSL-0525	5.25	45	95 (100)	10,080
ADSL-0530	5.3	45	95 (100)	8,400
ADSL-0535	5.35	45	95 (100)	10,080
ADSL-0540	5.4	45	95 (100)	8,400
ADSL-0545	5.45	45	95 (100)	10,080
ADSL-0550	5.5	45	95 (100)	8,400
ADSL-0555	5.55	45	95 (100)	11,150
ADSL-0560	5.6	45	98 (100)	9,280
ADSL-0565	5.65	45	98 (100)	11,150
ADSL-0570	5.7	45	98 (100)	9,280
ADSL-0575	5.75	45	98 (100)	11,150
ADSL-0580	5.8	45	98 (100)	9,280
ADSL-0585	5.85	45	98 (100)	11,150
ADSL-0590	5.9	45	98 (100)	9,280
ADSL-0595	5.95	45	98 (100)	11,150
ADSL-0600	6	50	102 (110)	9,280
ADSL-0610	6.1	50	102 (110)	12,500
ADSL-0620	6.2	50	102 (110)	12,500
ADSL-0630	6.3	50	102 (110)	12,500
ADSL-0640	6.4	50	105 (110)	15,100
ADSL-0650	6.5	50	105 (110)	15,100
ADSL-0660	6.6	50	105 (110)	15,100
ADSL-0670	6.7	50	105 (110)	15,100
ADSL-0680	6.8	50	105 (110)	15,100
ADSL-0690	6.9	50	105 (110)	15,100
ADSL-0700	7	50	105 (110)	14,000
ADSL-0710	7.1	52	108 (110)	16,900
ADSL-0720	7.2	52	108 (110)	16,900
ADSL-0730	7.3	52	108 (110)	16,900
ADSL-0740	7.4	52	111 (120)	18,100
ADSL-0750	7.5	52	111 (120)	18,100
ADSL-0760	7.6	52	111 (120)	18,100
ADSL-0770	7.7	55	114 (120)	18,300
ADSL-0780	7.8	55	114 (120)	18,300
ADSL-0790	7.9	55	114 (120)	18,300
ADSL-0800	8	60	117 (120)	17,500
ADSL-0810	8.1	60	117 (120)	20,600
ADSL-0820	8.2	60	117 (120)	20,600
ADSL-0830	8.3	60	117 (120)	20,600
ADSL-0840	8.4	60	121 (130)	24,500
ADSL-0850	8.5	60	121 (130)	24,500

※全長は ( ) 内表示寸法に順次変更します。



# ソリッド ロングドリル 〈ストレートシャンク〉

Long Drill, Straight Shank

## ADL

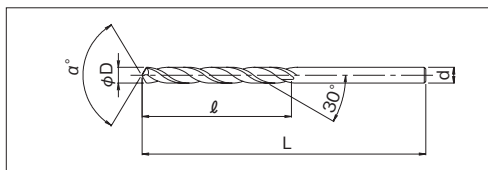

■ ADS標準ストレートシャンクドリルのロングタイプです。

Long type drill of ADS Standard Straight Shank Drill.

刃径公差：+0~-0.01

$\phi D$  Tolerance

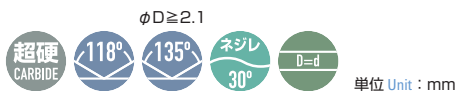

単位 Unit : mm

型番 CODE NUMBER	径 $\phi D$	刃長 $\ell$	全長 $L$	定価 ¥
ADL-0030	0.3	10	60	4,430
ADL-0035	0.35	10	60	4,430
ADL-0040	0.4	10	60	4,430
ADL-0045	0.45	10	60	4,430
ADL-0050	0.5	10	60	3,930
ADL-0055	0.55	15	65	3,930
ADL-0060	0.6	15	65	3,930
ADL-0065	0.65	15	65	3,930
ADL-0070	0.7	15	65	3,930
ADL-0075	0.75	15	65	3,930
ADL-0080	0.8	20	75	3,680
ADL-0085	0.85	20	75	3,680
ADL-0090	0.9	20	75	3,680
ADL-0095	0.95	20	75	3,680
ADL-0100	1	25	75	3,080
ADL-0105	1.05	25	75	3,780
ADL-0110	1.1	25	75	3,080
ADL-0115	1.15	25	75	3,780
ADL-0120	1.2	25	75	3,080
ADL-0125	1.25	25	75	3,780
ADL-0130	1.3	25	75	3,080
ADL-0135	1.35	25	75	3,780
ADL-0140	1.4	30	75	3,150
ADL-0145	1.45	30	75	3,780
ADL-0150	1.5	30	75	3,150
ADL-0155	1.55	30	75	3,780

型番 CODE NUMBER	径 $\phi D$	刃長 $\ell$	全長 $L$	定価 ¥
ADL-0160	1.6	30	75	3,150
ADL-0165	1.65	30	75	3,780
ADL-0170	1.7	30	75	3,150
ADL-0175	1.75	30	75	3,780
ADL-0180	1.8	30	75	3,150
ADL-0185	1.85	30	75	3,780
ADL-0190	1.9	30	75	3,150
ADL-0195	1.95	30	75	3,780
ADL-0200	2	30	75	4,670
ADL-0205	2.05	30	75	5,600
ADL-0210	2.1	30	75	4,670
ADL-0215	2.15	30	75	5,600
ADL-0220	2.2	30	75	4,670
ADL-0225	2.25	30	75	5,600
ADL-0230	2.3	30	75	4,670
ADL-0235	2.35	30	75	5,600
ADL-0240	2.4	35	100	5,830
ADL-0245	2.45	35	100	7,000
ADL-0250	2.5	35	100	5,830
ADL-0255	2.55	35	100	7,000
ADL-0260	2.6	35	100	5,830
ADL-0265	2.65	35	100	7,000
ADL-0270	2.7	35	100	5,830
ADL-0275	2.75	35	100	7,200
ADL-0280	2.8	35	100	6,000
ADL-0285	2.85	35	100	7,200

単位 Unit : mm

型番 CODE NUMBER	径 φD	刃長 ℓ	全長 L	定価 ¥
ADL-0290	2.9	35	100	6,000
ADL-0295	2.95	35	100	7,200
ADL-0300	3	50	100	6,670
ADL-0305	3.05	50	100	8,000
ADL-0310	3.1	50	100	6,670
ADL-0315	3.15	50	100	8,000
ADL-0320	3.2	50	100	6,670
ADL-0325	3.25	50	100	8,000
ADL-0330	3.3	50	100	6,670
ADL-0335	3.35	50	100	8,000
ADL-0340	3.4	50	100	7,970
ADL-0345	3.45	50	100	9,550
ADL-0350	3.5	50	100	7,970
ADL-0355	3.55	50	100	9,550
ADL-0360	3.6	50	100	8,500
ADL-0365	3.65	50	100	10,200
ADL-0370	3.7	50	100	8,500
ADL-0375	3.75	50	100	10,200
ADL-0380	3.8	50	100	8,500
ADL-0385	3.85	50	100	10,200
ADL-0390	3.9	50	100	8,500
ADL-0395	3.95	50	100	10,200
ADL-0400	4	50	100	9,100
ADL-0405	4.05	50	100	10,920
ADL-0410	4.1	50	100	9,100
ADL-0415	4.15	50	100	10,920
ADL-0420	4.2	50	100	9,100
ADL-0425	4.25	50	100	10,920
ADL-0430	4.3	50	100	9,100
ADL-0435	4.35	50	100	10,920
ADL-0440	4.4	50	100	9,570
ADL-0445	4.45	50	100	11,480
ADL-0450	4.5	50	100	9,570
ADL-0455	4.55	50	100	11,480
ADL-0460	4.6	50	100	10,670
ADL-0465	4.65	50	100	12,800
ADL-0470	4.7	50	100	10,670
ADL-0475	4.75	50	100	12,800
ADL-0480	4.8	50	100	10,670
ADL-0485	4.85	50	100	12,800
ADL-0490	4.9	50	100	10,670
ADL-0495	4.95	50	100	12,800
ADL-0500	5	75	150	15,330
ADL-0505	5.05	75	150	18,400

型番 CODE NUMBER	径 φD	刃長 ℓ	全長 L	定価 ¥
ADL-0510	5.1	75	150	15,330
ADL-0515	5.15	75	150	18,400
ADL-0520	5.2	75	150	15,330
ADL-0525	5.25	75	150	18,400
ADL-0530	5.3	75	150	15,330
ADL-0535	5.35	75	150	18,400
ADL-0540	5.4	75	150	15,330
ADL-0545	5.45	75	150	18,400
ADL-0550	5.5	75	150	15,330
ADL-0555	5.55	75	150	18,400
ADL-0560	5.6	75	150	17,500
ADL-0565	5.65	75	150	21,000
ADL-0570	5.7	75	150	17,500
ADL-0575	5.75	75	150	21,000
ADL-0580	5.8	75	150	17,500
ADL-0585	5.85	75	150	21,000
ADL-0590	5.9	75	150	17,500
ADL-0595	5.95	75	150	21,000
ADL-0600	6	75	150	17,500
ADL-0610	6.1	75	150	22,500
ADL-0620	6.2	75	150	22,500
ADL-0630	6.3	75	150	22,500
ADL-0640	6.4	75	150	22,500
ADL-0650	6.5	75	150	23,800
ADL-0660	6.6	75	150	23,800
ADL-0670	6.7	75	150	23,800
ADL-0680	6.8	75	150	23,800
ADL-0690	6.9	75	150	23,800
ADL-0700	7	75	150	22,000
ADL-0710	7.1	75	150	25,500
ADL-0720	7.2	75	150	25,500
ADL-0730	7.3	75	150	25,500
ADL-0740	7.4	75	150	25,500
ADL-0750	7.5	75	150	28,800
ADL-0760	7.6	75	150	28,800
ADL-0770	7.7	75	150	28,800
ADL-0780	7.8	75	150	28,800
ADL-0790	7.9	75	150	28,800
ADL-0800	8	75	150	26,500
ADL-0810	8.1	75	150	30,500
ADL-0820	8.2	75	150	30,500
ADL-0830	8.3	75	150	30,500
ADL-0840	8.4	75	150	30,500
ADL-0850	8.5	75	150	33,500

Next Page ▶





# ソリッド スーパーロングドリル 〈ストレートシャンク〉

## Super Long Drill, Straight Shank

# ADLL

■ ADS標準ストレートシャンクドリルの  
エクストラロングタイプです。

Extra Long type drill of ADS Standard Straight Shank Drill.

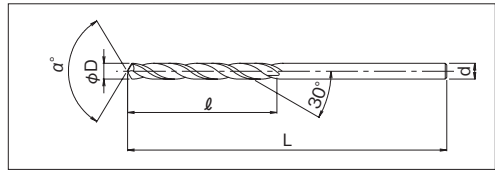

刃径公差：+0~-0.01  
φD Tolerance

型番 CODE NUMBER	径 φD	刃長 l	全長 L	定価 ¥
ADLL-0030	0.3	15	75	5,650
ADLL-0035	0.35	15	75	5,650
ADLL-0040	0.4	15	75	5,650
ADLL-0045	0.45	15	75	5,650
ADLL-0050	0.5	15	75	4,530
ADLL-0055	0.55	20	90	4,530
ADLL-0060	0.6	20	90	4,530
ADLL-0065	0.65	20	90	4,530
ADLL-0070	0.7	20	90	4,530
ADLL-0075	0.75	20	90	4,530
ADLL-0080	0.8	25	100	4,230
ADLL-0085	0.85	25	100	4,230
ADLL-0090	0.9	25	100	4,230
ADLL-0095	0.95	25	100	4,230
ADLL-0100	1	30	100	3,430
ADLL-0105	1.05	30	100	4,130
ADLL-0110	1.1	30	100	3,430
ADLL-0115	1.15	30	100	4,130
ADLL-0120	1.2	35	100	3,430
ADLL-0125	1.25	35	100	4,130
ADLL-0130	1.3	35	100	3,430
ADLL-0135	1.35	35	100	4,130
ADLL-0140	1.4	40	100	3,780
ADLL-0145	1.45	40	100	4,550
ADLL-0150	1.5	40	100	3,780
ADLL-0155	1.55	40	100	4,550

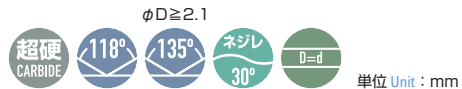

型番 CODE NUMBER	径 φD	刃長 l	全長 L	定価 ¥
ADLL-0160	1.6	40	100	3,780
ADLL-0165	1.65	40	100	4,550
ADLL-0170	1.7	40	100	3,780
ADLL-0175	1.75	40	100	4,550
ADLL-0180	1.8	40	100	3,780
ADLL-0185	1.85	40	100	4,550
ADLL-0190	1.9	40	100	3,780
ADLL-0195	1.95	40	100	4,550
ADLL-0200	2	40	100	5,680
ADLL-0205	2.05	40	100	6,830
ADLL-0210	2.1	40	100	5,680
ADLL-0215	2.15	40	100	6,830
ADLL-0220	2.2	40	100	5,680
ADLL-0225	2.25	40	100	6,830
ADLL-0230	2.3	40	100	5,680
ADLL-0235	2.35	40	100	6,830
ADLL-0240	2.4	50	150	7,170
ADLL-0245	2.45	50	150	8,600
ADLL-0250	2.5	50	150	7,170
ADLL-0255	2.55	50	150	8,600
ADLL-0260	2.6	50	150	9,270
ADLL-0265	2.65	50	150	11,130
ADLL-0270	2.7	50	150	9,270
ADLL-0275	2.75	50	150	11,130
ADLL-0280	2.8	50	150	9,270
ADLL-0285	2.85	50	150	11,130

Next Page ▶

## ADLL ソリッドスーパーロングドリル〈ストレートシャンク〉

単位 Unit : mm

型番 CODE NUMBER	径 φD	刃長 ℓ	全長 L	定価 ¥
ADLL-0290	2.9	50	150	9,270
ADLL-0295	2.95	50	150	11,130
ADLL-0300	3	65	150	10,080
ADLL-0305	3.05	65	150	12,100
ADLL-0310	3.1	65	150	10,080
ADLL-0315	3.15	65	150	12,100
ADLL-0320	3.2	65	150	10,080
ADLL-0325	3.25	65	150	12,100
ADLL-0330	3.3	65	150	10,080
ADLL-0335	3.35	65	150	12,100
ADLL-0340	3.4	65	150	10,730
ADLL-0345	3.45	65	150	12,050
ADLL-0350	3.5	65	150	10,730
ADLL-0355	3.55	65	150	14,570
ADLL-0360	3.6	75	150	12,130
ADLL-0365	3.65	75	150	14,570
ADLL-0370	3.7	75	150	12,130
ADLL-0375	3.75	75	150	14,570
ADLL-0380	3.8	75	150	12,130
ADLL-0385	3.85	75	150	14,570
ADLL-0390	3.9	75	150	12,130
ADLL-0395	3.95	75	150	15,400
ADLL-0400	4	75	150	12,830
ADLL-0405	4.05	75	150	15,400
ADLL-0410	4.1	75	150	12,830
ADLL-0415	4.15	75	150	15,400
ADLL-0420	4.2	75	150	12,830
ADLL-0425	4.25	75	150	15,400
ADLL-0430	4.3	75	150	12,830
ADLL-0435	4.35	75	150	15,400
ADLL-0440	4.4	75	150	13,670
ADLL-0445	4.45	75	150	16,400
ADLL-0450	4.5	75	150	13,670
ADLL-0455	4.55	75	150	16,400
ADLL-0460	4.6	75	150	15,170
ADLL-0465	4.65	75	150	18,200
ADLL-0470	4.7	75	150	15,170
ADLL-0475	4.75	75	150	18,200
ADLL-0480	4.8	75	150	15,170
ADLL-0485	4.85	75	150	18,200
ADLL-0490	4.9	75	150	15,170
ADLL-0495	4.95	75	150	21,600
ADLL-0500	5	90	200	18,000
ADLL-0505	5.05	90	200	21,800

型番 CODE NUMBER	径 φD	刃長 ℓ	全長 L	定価 ¥
ADLL-0510	5.1	90	200	18,170
ADLL-0515	5.15	90	200	21,800
ADLL-0520	5.2	90	200	18,170
ADLL-0525	5.25	90	200	21,800
ADLL-0530	5.3	90	200	18,170
ADLL-0535	5.35	90	200	21,800
ADLL-0540	5.4	90	200	18,170
ADLL-0545	5.45	90	200	21,800
ADLL-0550	5.5	90	200	18,170
ADLL-0555	5.55	90	200	28,000
ADLL-0560	5.6	90	200	23,330
ADLL-0565	5.65	90	200	28,000
ADLL-0570	5.7	90	200	23,330
ADLL-0575	5.75	90	200	28,000
ADLL-0580	5.8	90	200	23,330
ADLL-0585	5.85	90	200	28,000
ADLL-0590	5.9	90	200	23,330
ADLL-0595	5.95	90	200	28,000
ADLL-0600	6	90	200	23,330
ADLL-0610	6.1	90	200	29,800
ADLL-0620	6.2	90	200	29,800
ADLL-0630	6.3	90	200	29,800
ADLL-0640	6.4	90	200	29,800
ADLL-0650	6.5	90	200	32,100
ADLL-0660	6.6	90	200	32,100
ADLL-0670	6.7	90	200	32,100
ADLL-0680	6.8	90	200	32,100
ADLL-0690	6.9	90	200	32,100
ADLL-0700	7	90	200	30,700
ADLL-0710	7.1	90	200	35,100
ADLL-0720	7.2	90	200	35,100
ADLL-0730	7.3	90	200	35,100
ADLL-0740	7.4	90	200	35,100
ADLL-0750	7.5	90	200	38,500
ADLL-0760	7.6	90	200	38,500
ADLL-0770	7.7	90	200	38,500
ADLL-0780	7.8	90	200	38,500
ADLL-0790	7.9	90	200	38,500
ADLL-0800	8	90	200	35,500
ADLL-0810	8.1	90	200	41,300
ADLL-0820	8.2	90	200	41,300
ADLL-0830	8.3	90	200	41,300
ADLL-0840	8.4	90	200	41,300
ADLL-0850	8.5	90	200	45,200



# コーティング付き標準ソリッドドリル 〈ストレートシャンク〉

Solid Coated Drill, standard Straight Shank

TiAIN コーティング

## V-ADS

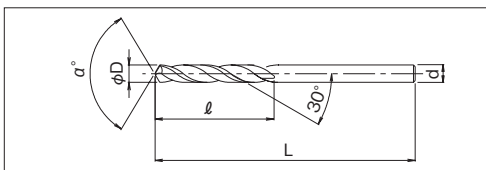

- ADS標準タイプにTiAINコーティングを施し更に長寿命と安定加工を実現。  
TiAIN coating on standard drill (ADS) assures longer tool life and stable drilling operation.
- ノンコート標準品では加工困難であった50HRCまでの焼入鋼の穴あけも可能です。  
V-ADS can drill quenched and tempered steels up to 50HRC.

刃径公差：+0~-0.01  
φD Tolerance



単位 Unit : mm

型番 CODE NUMBER	径 φD	刃長 ℓ	全長 L	定価 ¥
V-ADS-0030	0.3	4	30	3,030
V-ADS-0031	0.31	4	30	3,430
V-ADS-0032	0.32	4	30	3,430
V-ADS-0033	0.33	4	30	3,430
V-ADS-0034	0.34	4	30	3,430
V-ADS-0035	0.35	4	30	3,430
V-ADS-0036	0.36	4	30	3,430
V-ADS-0037	0.37	4	30	3,430
V-ADS-0038	0.38	4	30	3,430
V-ADS-0039	0.39	4	30	3,430
V-ADS-0040	0.4	5	30	2,900
V-ADS-0041	0.41	5	30	3,400
V-ADS-0042	0.42	5	30	3,400
V-ADS-0043	0.43	5	30	3,400
V-ADS-0044	0.44	5	30	3,400
V-ADS-0045	0.45	5	30	3,400
V-ADS-0046	0.46	5	30	3,400
V-ADS-0047	0.47	5	30	3,400
V-ADS-0048	0.48	5	30	3,400
V-ADS-0049	0.49	5	30	3,400
V-ADS-0050	0.5	6	30	2,400
V-ADS-0051	0.51	6	30	2,850
V-ADS-0052	0.52	6	30	2,850
V-ADS-0053	0.53	6	30	2,850
V-ADS-0054	0.54	6	30	2,850
V-ADS-0055	0.55	6	30	2,850

型番 CODE NUMBER	径 φD	刃長 ℓ	全長 L	定価 ¥
V-ADS-0056	0.56	6	30	2,850
V-ADS-0057	0.57	6	30	2,850
V-ADS-0058	0.58	6	30	2,850
V-ADS-0059	0.59	6	30	2,850
V-ADS-0060	0.6	6	30	2,530
V-ADS-0061	0.61	6	30	2,850
V-ADS-0062	0.62	6	30	2,850
V-ADS-0063	0.63	6	30	2,850
V-ADS-0064	0.64	6	30	2,850
V-ADS-0065	0.65	6	30	2,850
V-ADS-0066	0.66	6	30	2,850
V-ADS-0067	0.67	6	30	2,850
V-ADS-0068	0.68	6	30	2,850
V-ADS-0069	0.69	6	30	2,850
V-ADS-0070	0.7	12	40	2,530
V-ADS-0071	0.71	12	40	2,970
V-ADS-0072	0.72	12	40	2,970
V-ADS-0073	0.73	12	40	2,970
V-ADS-0074	0.74	12	40	2,970
V-ADS-0075	0.75	12	40	2,970
V-ADS-0076	0.76	12	40	2,970
V-ADS-0077	0.77	12	40	2,970
V-ADS-0078	0.78	12	40	2,970
V-ADS-0079	0.79	12	40	2,970
V-ADS-0080	0.8	12	40	2,730
V-ADS-0081	0.81	12	40	2,970

単位 Unit : mm

型番 CODE NUMBER	径 φD	刃長 ℓ	全長 L	定価 ¥
V-ADS-0082	0.82	12	40	2,970
V-ADS-0083	0.83	12	40	2,970
V-ADS-0084	0.84	12	40	2,970
V-ADS-0085	0.85	12	40	2,970
V-ADS-0086	0.86	12	40	2,970
V-ADS-0087	0.87	12	40	2,970
V-ADS-0088	0.88	12	40	2,970
V-ADS-0089	0.89	12	40	2,970
V-ADS-0090	0.9	12	40	2,670
V-ADS-0091	0.91	12	40	2,970
V-ADS-0092	0.92	12	40	2,970
V-ADS-0093	0.93	12	40	2,970
V-ADS-0094	0.94	12	40	2,970
V-ADS-0095	0.95	12	40	2,970
V-ADS-0096	0.96	12	40	2,970
V-ADS-0097	0.97	12	40	2,970
V-ADS-0098	0.98	12	40	2,970
V-ADS-0099	0.99	12	40	2,970
V-ADS-0100	1	15	40	2,400
V-ADS-0101	1.01	15	40	2,730
V-ADS-0102	1.02	15	40	2,730
V-ADS-0103	1.03	15	40	2,730
V-ADS-0104	1.04	15	40	2,730
V-ADS-0105	1.05	15	40	2,730
V-ADS-0106	1.06	15	40	2,730
V-ADS-0107	1.07	15	40	2,730
V-ADS-0108	1.08	15	40	2,730
V-ADS-0109	1.09	15	40	2,730
V-ADS-0110	1.1	15	40	2,400
V-ADS-0111	1.11	15	40	2,730
V-ADS-0112	1.12	15	40	2,730
V-ADS-0113	1.13	15	40	2,730
V-ADS-0114	1.14	15	40	2,730
V-ADS-0115	1.15	15	40	2,730
V-ADS-0116	1.16	15	40	2,730
V-ADS-0117	1.17	15	40	2,730
V-ADS-0118	1.18	15	40	2,730
V-ADS-0119	1.19	15	40	2,730
V-ADS-0120	1.2	15	40	2,400
V-ADS-0121	1.21	15	40	2,730
V-ADS-0122	1.22	15	40	2,730
V-ADS-0123	1.23	15	40	2,730
V-ADS-0124	1.24	15	40	2,730
V-ADS-0125	1.25	15	40	2,730

型番 CODE NUMBER	径 φD	刃長 ℓ	全長 L	定価 ¥
V-ADS-0126	1.26	15	40	2,730
V-ADS-0127	1.27	15	40	2,730
V-ADS-0128	1.28	15	40	2,730
V-ADS-0129	1.29	15	40	2,730
V-ADS-0130	1.3	16	40	2,400
V-ADS-0131	1.31	16	40	2,730
V-ADS-0132	1.32	16	40	2,730
V-ADS-0133	1.33	16	40	2,730
V-ADS-0134	1.34	16	40	2,730
V-ADS-0135	1.35	16	40	2,730
V-ADS-0136	1.36	16	40	2,730
V-ADS-0137	1.37	16	40	2,730
V-ADS-0138	1.38	16	40	2,730
V-ADS-0139	1.39	16	40	2,730
V-ADS-0140	1.4	16	40	2,400
V-ADS-0141	1.41	16	40	2,730
V-ADS-0142	1.42	16	40	2,730
V-ADS-0143	1.43	16	40	2,730
V-ADS-0144	1.44	16	40	2,730
V-ADS-0145	1.45	16	40	2,730
V-ADS-0146	1.46	16	40	2,730
V-ADS-0147	1.47	16	40	2,730
V-ADS-0148	1.48	16	40	2,730
V-ADS-0149	1.49	16	40	2,730
V-ADS-0150	1.5	16	40	2,400
V-ADS-0151	1.51	16	40	3,120
V-ADS-0152	1.52	16	40	3,120
V-ADS-0153	1.53	16	40	3,120
V-ADS-0154	1.54	16	40	3,120
V-ADS-0155	1.55	16	40	3,120
V-ADS-0156	1.56	16	40	3,120
V-ADS-0157	1.57	16	40	3,120
V-ADS-0158	1.58	16	40	3,120
V-ADS-0159	1.59	16	40	3,120
V-ADS-0160	1.6	18	40	2,670
V-ADS-0161	1.61	18	40	3,120
V-ADS-0162	1.62	18	40	3,120
V-ADS-0163	1.63	18	40	3,120
V-ADS-0164	1.64	18	40	3,120
V-ADS-0165	1.65	18	40	3,120
V-ADS-0166	1.66	18	40	3,120
V-ADS-0167	1.67	18	40	3,120
V-ADS-0168	1.68	18	40	3,120
V-ADS-0169	1.69	18	40	3,120

Next Page ▶



単位 Unit : mm

型番 CODE NUMBER	径 φD	刃長 ℓ	全長 L	定価 ¥
V-ADS-0258	2.58	20	40 (45)	4,130
V-ADS-0259	2.59	20	40 (45)	4,130
V-ADS-0260	2.6	20	45	3,500
V-ADS-0261	2.61	20	45	4,130
V-ADS-0262	2.62	20	45	4,130
V-ADS-0263	2.63	20	45	4,130
V-ADS-0264	2.64	20	45	4,130
V-ADS-0265	2.65	20	45	4,130
V-ADS-0266	2.66	20	45	4,130
V-ADS-0267	2.67	20	45	4,130
V-ADS-0268	2.68	20	45	4,130
V-ADS-0269	2.69	20	45	4,130
V-ADS-0270	2.7	20	45	3,570
V-ADS-0271	2.71	20	45	4,130
V-ADS-0272	2.72	20	45	4,130
V-ADS-0273	2.73	20	45	4,130
V-ADS-0274	2.74	20	45	4,130
V-ADS-0275	2.75	20	45	4,130
V-ADS-0276	2.76	20	45	4,130
V-ADS-0277	2.77	20	45	4,130
V-ADS-0278	2.78	20	45	4,130
V-ADS-0279	2.79	20	45	4,130
V-ADS-0280	2.8	20	45	3,570
V-ADS-0281	2.81	20	45	4,130
V-ADS-0282	2.82	20	45	4,130
V-ADS-0283	2.83	20	45	4,130
V-ADS-0284	2.84	20	45	4,130
V-ADS-0285	2.85	20	45	4,130
V-ADS-0286	2.86	20	45	4,130
V-ADS-0287	2.87	20	45	4,130
V-ADS-0288	2.88	20	45	4,130
V-ADS-0289	2.89	20	45	4,130
V-ADS-0290	2.9	20	45	3,570
V-ADS-0291	2.91	20	45	4,130
V-ADS-0292	2.92	20	45	4,130
V-ADS-0293	2.93	20	45	4,130
V-ADS-0294	2.94	20	45	4,130
V-ADS-0295	2.95	20	45	4,130
V-ADS-0296	2.96	20	45	4,130
V-ADS-0297	2.97	20	45	4,130
V-ADS-0298	2.98	20	45	4,130
V-ADS-0299	2.99	20	45	4,130
V-ADS-0300	3	20	45	3,800
V-ADS-0305	3.05	20	45	5,000

※全長は ( ) 内表示寸法に順次変更します。

型番 CODE NUMBER	径 φD	刃長 ℓ	全長 L	定価 ¥
V-ADS-0310	3.1	25	50	4,130
V-ADS-0315	3.15	25	50	5,000
V-ADS-0320	3.2	25	50	4,130
V-ADS-0325	3.25	25	50	5,000
V-ADS-0330	3.3	25	50	4,130
V-ADS-0335	3.35	25	50	5,000
V-ADS-0340	3.4	25	50	4,130
V-ADS-0345	3.45	25	50	5,000
V-ADS-0350	3.5	25	50	4,130
V-ADS-0355	3.55	25	50	6,220
V-ADS-0360	3.6	27	55	5,330
V-ADS-0365	3.65	27	55	6,220
V-ADS-0370	3.7	27	55	5,330
V-ADS-0375	3.75	27	55	6,220
V-ADS-0380	3.8	27	55	5,330
V-ADS-0385	3.85	27	55	6,220
V-ADS-0390	3.9	27	55	5,530
V-ADS-0395	3.95	27	55	6,420
V-ADS-0400	4	27	55	5,530
V-ADS-0405	4.05	27	55	7,280
V-ADS-0410	4.1	30	60	6,330
V-ADS-0415	4.15	30	60	7,280
V-ADS-0420	4.2	30	60	6,300
V-ADS-0425	4.25	30	60	7,280
V-ADS-0430	4.3	30	60	6,300
V-ADS-0435	4.35	30	60	7,280
V-ADS-0440	4.4	30	60	6,300
V-ADS-0445	4.45	30	60	7,280
V-ADS-0450	4.5	30	60	6,300
V-ADS-0455	4.55	30	60	8,270
V-ADS-0460	4.6	30	60	6,880
V-ADS-0465	4.65	30	60	8,270
V-ADS-0470	4.7	30	60	6,880
V-ADS-0475	4.75	30	60	8,270
V-ADS-0480	4.8	30	60	7,150
V-ADS-0485	4.85	30	60	8,280
V-ADS-0490	4.9	30	60	7,150
V-ADS-0495	4.95	30	60	8,280
V-ADS-0500	5	30	60	7,150
V-ADS-0505	5.05	30	60	10,080
V-ADS-0510	5.1	40	80	8,280
V-ADS-0515	5.15	40	80	10,080
V-ADS-0520	5.2	40	80	8,280
V-ADS-0525	5.25	40	80	10,080

Next Page ▶





# “マックスアル” アルミ用ドリル 〈ストレートシャンク〉

## "MAXAL" Drill, Straight Shank, for Aluminium

# ACD

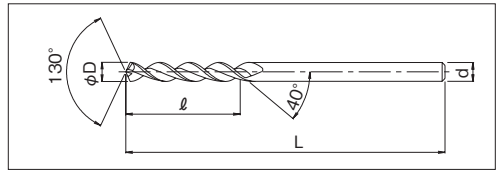

- アルミ用に特殊設計された先端形状、溝形状により切粉がスムーズに排出されます。  
Ideal chip ejection is assured due to unique design of point and flute configuration.
- 先端シンニング付きですのでワークへの食い付きが良く穴曲りも抑制されます。  
The thinning point allows smoother entering when the drill digs in and prevents off-angle hole.

刃径公差：+0~-0.01  
φD Tolerance

型番 CODE NUMBER	径 φD	刃長 ℓ	全長 L	定価 ¥
ACD-0100	1	15	40	2,250
ACD-0110	1.1	15	40	2,250
ACD-0120	1.2	15	40	2,250
ACD-0130	1.3	16	40	2,250
ACD-0140	1.4	16	40	2,250
ACD-0150	1.5	16	40	2,250
ACD-0160	1.6	18	40	2,750
ACD-0170	1.7	18	40	2,750
ACD-0180	1.8	18	40	2,750
ACD-0190	1.9	18	40	2,750
ACD-0200	2	18	40	2,750
ACD-0210	2.1	20	40 (45)	2,880
ACD-0220	2.2	20	40 (45)	2,880
ACD-0230	2.3	20	40 (45)	2,880
ACD-0240	2.4	20	40 (45)	2,880
ACD-0250	2.5	20	40 (45)	2,880
ACD-0260	2.6	20	45	3,500
ACD-0270	2.7	20	45	3,500
ACD-0280	2.8	20	45	3,500
ACD-0290	2.9	20	45	3,500
ACD-0300	3	20	45	3,500
ACD-0310	3.1	25	50	4,380
ACD-0320	3.2	25	50	4,380
ACD-0330	3.3	25	50	4,380
ACD-0340	3.4	25	50	4,380
ACD-0350	3.5	25	50	4,380

超硬 CARBIDE 130° ネジレ 40° X形 Thinning D=d 単位 Unit : mm

型番 CODE NUMBER	径 φD	刃長 ℓ	全長 L	定価 ¥
ACD-0360	3.6	27	55	5,630
ACD-0370	3.7	27	55	5,630
ACD-0380	3.8	27	55	5,630
ACD-0390	3.9	27	55	5,630
ACD-0400	4	27	55	5,630
ACD-0410	4.1	30	60	6,500
ACD-0420	4.2	30	60	6,500
ACD-0430	4.3	30	60	6,500
ACD-0440	4.4	30	60	6,500
ACD-0450	4.5	30	60	6,500
ACD-0460	4.6	30	60	7,380
ACD-0470	4.7	30	60	7,380
ACD-0480	4.8	30	60	7,380
ACD-0490	4.9	30	60	7,380
ACD-0500	5	30	60	7,380
ACD-0510	5.1	40	65 (80)	8,630
ACD-0520	5.2	40	65 (80)	8,630
ACD-0530	5.3	40	65 (80)	8,630
ACD-0540	5.4	40	65 (80)	8,630
ACD-0550	5.5	40	65 (80)	8,630
ACD-0560	5.6	40	65 (80)	9,630
ACD-0570	5.7	40	65 (80)	9,630
ACD-0580	5.8	40	65 (80)	9,630
ACD-0590	5.9	40	65 (80)	9,630
ACD-0600	6	40	65 (80)	9,630
ACD-0610	6.1	40	65 (80)	12,800

※全長は（ ）内表示寸法に順次変更します。

Next Page ▶





ガイド穴専用ドリル High Precision Guide Hole Drill

# 超硬 NCポインティングドリル

Solid Carbide NC Pointing Drill

ドリル径 Drill  $\phi$  :  $\phi 0.03 \sim \phi 3.0\text{mm}$

## 120° タイプ 位置決め専用



## 90° タイプ 位置決め+面取り加工



### ■ 特徴

- 小径・微小径穴加工用に設計されたガイド(センター)穴専用ドリルです。
- $\phi 0.3 \sim \phi 0.95$ はシンニングを施し、小径で高い位置精度のガイド穴が得られます。
- $\phi 1$ 以上はシンニング無しで先端チゼル幅を小さく設計。高い位置精度を確保しながら、中心付近まで先端角を有効に使用できます。
- 共にガイド穴底辺の幅は二次工程ドリル芯厚より狭く保たれます。

### Features

- Special Guide-Hole Drills developed for use in drilling small / microdiameter holes.
- The chisel edge width is designed smaller, and the width of guide hole base is always kept narrower than the core thickness of secondary using drill.
- Thinning on the drill point lets you drill holes with greater positioning accuracy.

### ■ 用途・効果

- 穴位置精度・穴径の公差が厳しい加工。
- ピッチ精度が厳しい小径多孔穴あけ加工。
- 正確なガイド穴により加工穴曲りを防ぎます。
- ドリル食い付き時に起こる刃先の破損、チッピングを防ぎます。

### Uses & Advantages

- Work that requires stringent hole-position and hole-diameter tolerance.
- Work of opening small diameter perforation holes with strict pitch accuracy.
- Prevents off-angle hole drilling with accurate guide hole.
- Prevents drill damage and chipping that occur when the drill digs in.

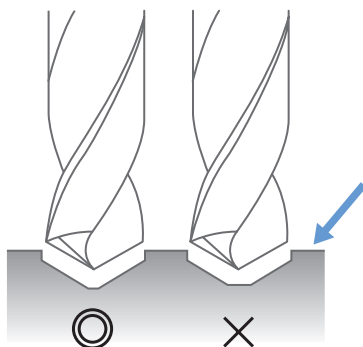

ガイド穴の底辺が広いと正確な穴位置が得られません。

If the base of guide hole is wider, accurate hole position can not be achieved.

### ■ ポインティングドリル選定表 Pointing Drill Selection Table

先端角 Point Angle	被削材 Materials	型番 Model	シャンク径 Shank Dia.
120°	鋼材用 for Steel	ADPF30	$\phi 3$
		V-ADPF30	$\phi 3$
		ADPF31	$\phi 3.175$
		V-ADPF31	$\phi 3.175$
	非鉄・樹脂用 for Non Ferrous & Resin	ADPN30	$\phi 3$
		ADPN31	$\phi 3.175$
90°	鋼材用 for Steel	ADPF309	$\phi 3$
		V-ADPF309	$\phi 3$
	非鉄・樹脂用 for Non Ferrous & Resin	ADPN309	$\phi 3$

V-ADPF30/31/309はTiAlNコーティング付です。

先端120° ガイド穴専用ドリル Guide Hole Drill

## NCポインティングドリル

NC Pointing Drill with 120° point angle

ADPF30

鋼材用

for Ferrous material

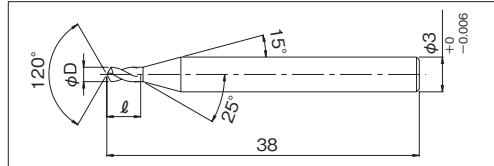

■ 微小径穴加工用のガイド穴専用ドリルです。

Special guide-hole drills for use in drilling small holes.

■ 穴位置・穴径精度の厳しい加工に最適です。

Most suitable for work that requires stringent hole position accuracy.

φ0.03～φ0.04は首逃げ2段形状です。

刃径公差：φD Tolerance

-0.005～-0.01 (≤φ0.09)

-0.01～-0.015 (≥φ0.1)

0.3≤φD≤0.95



単位 Unit : mm

型番 CODE NUMBER	径 φD	刃長 ℓ	全長 L	シャンク d	定価 ¥
ADPF30-0003	0.03	0.06	38	3	20,000
ADPF30-0004	0.04	0.08	38	3	17,340
ADPF30-0005	0.05	0.1	38	3	15,170
ADPF30-0006	0.06	0.1	38	3	12,840
ADPF30-0007	0.07	0.1	38	3	10,040
ADPF30-0008	0.08	0.1	38	3	8,990
ADPF30-0009	0.09	0.1	38	3	7,700
ADPF30-0010	0.1	0.2	38	3	7,000
ADPF30-0011	0.11	0.2	38	3	7,670
ADPF30-0012	0.12	0.2	38	3	7,670
ADPF30-0013	0.13	0.2	38	3	7,670
ADPF30-0014	0.14	0.2	38	3	7,670
ADPF30-0015	0.15	0.2	38	3	7,000
ADPF30-0016	0.16	0.3	38	3	7,670
ADPF30-0017	0.17	0.3	38	3	7,670
ADPF30-0018	0.18	0.3	38	3	7,670
ADPF30-0019	0.19	0.3	38	3	7,670
ADPF30-0020	0.2	0.4	38	3	6,300
ADPF30-0021	0.21	0.4	38	3	7,000
ADPF30-0022	0.22	0.4	38	3	7,000
ADPF30-0023	0.23	0.4	38	3	7,000
ADPF30-0024	0.24	0.4	38	3	7,000
ADPF30-0025	0.25	0.4	38	3	6,300
ADPF30-0026	0.26	0.5	38	3	7,000
ADPF30-0027	0.27	0.5	38	3	7,000
ADPF30-0028	0.28	0.5	38	3	7,000
ADPF30-0029	0.29	0.5	38	3	7,000
ADPF30-0030	0.3	0.6	38	3	6,200
ADPF30-0035	0.35	0.6	38	3	6,200
ADPF30-0040	0.4	0.6	38	3	6,200
ADPF30-0045	0.45	0.6	38	3	6,200

型番 CODE NUMBER	径 φD	刃長 ℓ	全長 L	シャンク d	定価 ¥
ADPF30-0050	0.5	1	38	3	5,600
ADPF30-0055	0.55	1	38	3	6,200
ADPF30-0060	0.6	1	38	3	6,200
ADPF30-0065	0.65	1	38	3	6,200
ADPF30-0070	0.7	1.2	38	3	6,200
ADPF30-0075	0.75	1.2	38	3	6,200
ADPF30-0080	0.8	1.2	38	3	6,200
ADPF30-0085	0.85	1.2	38	3	6,200
ADPF30-0090	0.9	1.8	38	3	6,200
ADPF30-0095	0.95	1.8	38	3	6,200
ADPF30-0100	1	2(1.8)	38	3	5,600
ADPF30-0110	1.1	2	38	3	6,200
ADPF30-0120	1.2	2	38	3	6,200
ADPF30-0130	1.3	3	38	3	6,200
ADPF30-0140	1.4	3	38	3	6,200
ADPF30-0150	1.5	3(2.5)	38	3	5,600
ADPF30-0160	1.6	3	38	3	6,200
ADPF30-0170	1.7	3	38	3	6,200
ADPF30-0180	1.8	4	38	3	6,200
ADPF30-0190	1.9	4	38	3	6,200
ADPF30-0200	2	4(2.5)	38	3	5,600
ADPF30-0210	2.1	4	38	3	6,200
ADPF30-0220	2.2	4	38	3	6,200
ADPF30-0230	2.3	5	38	3	6,200
ADPF30-0240	2.4	5	38	3	6,200
ADPF30-0250	2.5	5(3)	38	3	5,600
ADPF30-0260	2.6	5	38	3	6,200
ADPF30-0270	2.7	5	38	3	6,200
ADPF30-0280	2.8	5	38	3	6,200
ADPF30-0290	2.9	5	38	3	6,200
ADPF30-0300	3	5(3)	38	3	5,600

※ ( ) 内刃長は旧仕様となります。

先端120° ガイド穴専用ドリル Guide Hole Drill

# NCポインティングドリル

NC Pointing Drill with 120° point angle

## V-ADPF30

鋼材用, TiAlNコーティング  
for Ferrous material, TiAlN Coating

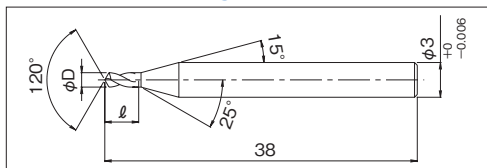

■ 微小径穴加工用のガイド穴専用ドリルです。

Special guide-hole drills for use in drilling small holes.

φ0.03~φ0.04は首逃げ2段形状です。

■ 穴位置・穴径精度の厳しい加工に最適です。

Most suitable for work that requires stringent hole position accuracy.

■ TiAlNコーティングにより耐摩耗性が向上、長寿命加工を実現します。

TiAlN coated improves wear resistance and extends its toll life.

刃径公差：φD Tolerance

-0.002~-0.009 (φ0.03~φ0.09)

-0.007~-0.014 (φ0.1~φ0.29)

-0.005~-0.013 (φ0.3~φ3)



0.3 ≤ φD ≤ 0.95

単位 Unit : mm

型番 CODE NUMBER	径 φD	刃長 ℓ	全長 L	シャク d	定価 ¥
V-ADPF30-0003	0.03	0.06	38	3	22,730
V-ADPF30-0004	0.04	0.08	38	3	20,070
V-ADPF30-0005	0.05	0.1	38	3	17,900
V-ADPF30-0006	0.06	0.1	38	3	15,570
V-ADPF30-0007	0.07	0.1	38	3	11,930
V-ADPF30-0008	0.08	0.1	38	3	10,900
V-ADPF30-0009	0.09	0.1	38	3	9,600
V-ADPF30-0010	0.1	0.2	38	3	8,400
V-ADPF30-0011	0.11	0.2	38	3	9,070
V-ADPF30-0012	0.12	0.2	38	3	9,070
V-ADPF30-0013	0.13	0.2	38	3	9,070
V-ADPF30-0014	0.14	0.2	38	3	9,070
V-ADPF30-0015	0.15	0.2	38	3	8,400
V-ADPF30-0016	0.16	0.3	38	3	9,070
V-ADPF30-0017	0.17	0.3	38	3	9,070
V-ADPF30-0018	0.18	0.3	38	3	9,070
V-ADPF30-0019	0.19	0.3	38	3	9,070
V-ADPF30-0020	0.2	0.4	38	3	7,700
V-ADPF30-0021	0.21	0.4	38	3	8,330
V-ADPF30-0022	0.22	0.4	38	3	8,330
V-ADPF30-0023	0.23	0.4	38	3	8,330
V-ADPF30-0024	0.24	0.4	38	3	8,330
V-ADPF30-0025	0.25	0.4	38	3	7,700
V-ADPF30-0026	0.26	0.5	38	3	8,330
V-ADPF30-0027	0.27	0.5	38	3	8,330
V-ADPF30-0028	0.28	0.5	38	3	8,330
V-ADPF30-0029	0.29	0.5	38	3	8,330
V-ADPF30-0030	0.3	0.6	38	3	7,400
V-ADPF30-0035	0.35	0.6	38	3	7,400
V-ADPF30-0040	0.4	0.6	38	3	7,400
V-ADPF30-0045	0.45	0.6	38	3	7,400

型番 CODE NUMBER	径 φD	刃長 ℓ	全長 L	シャク d	定価 ¥
V-ADPF30-0050	0.5	1	38	3	6,730
V-ADPF30-0055	0.55	1	38	3	7,400
V-ADPF30-0060	0.6	1	38	3	7,400
V-ADPF30-0065	0.65	1	38	3	7,400
V-ADPF30-0070	0.7	1.2	38	3	7,400
V-ADPF30-0075	0.75	1.2	38	3	7,400
V-ADPF30-0080	0.8	1.2	38	3	7,400
V-ADPF30-0085	0.85	1.2	38	3	7,400
V-ADPF30-0090	0.9	1.8	38	3	7,400
V-ADPF30-0095	0.95	1.8	38	3	7,400
V-ADPF30-0100	1	2(1.8)	38	3	6,730
V-ADPF30-0110	1.1	2	38	3	7,400
V-ADPF30-0120	1.2	2	38	3	7,400
V-ADPF30-0130	1.3	3	38	3	7,400
V-ADPF30-0140	1.4	3	38	3	7,400
V-ADPF30-0150	1.5	3(2.5)	38	3	6,730
V-ADPF30-0160	1.6	3	38	3	7,400
V-ADPF30-0170	1.7	3	38	3	7,400
V-ADPF30-0180	1.8	4	38	3	7,400
V-ADPF30-0190	1.9	4	38	3	7,400
V-ADPF30-0200	2	4(2.5)	38	3	6,730
V-ADPF30-0210	2.1	4	38	3	7,400
V-ADPF30-0220	2.2	4	38	3	7,400
V-ADPF30-0230	2.3	5	38	3	7,400
V-ADPF30-0240	2.4	5	38	3	7,400
V-ADPF30-0250	2.5	5(3)	38	3	6,730
V-ADPF30-0260	2.6	5	38	3	7,400
V-ADPF30-0270	2.7	5	38	3	7,400
V-ADPF30-0280	2.8	5	38	3	7,400
V-ADPF30-0290	2.9	5	38	3	7,400
V-ADPF30-0300	3	5(3)	38	3	6,730

※ ( ) 内刃長は旧仕様となります。

先端120° ガイド穴専用ドリル Guide Hole Drill

## NCポインティングドリル〈3.175mmシャンク〉

NC Pointing Drill with 120° point angle and 3.175mm(1/8") shank

ADPF31

鋼材用

for Ferrous material

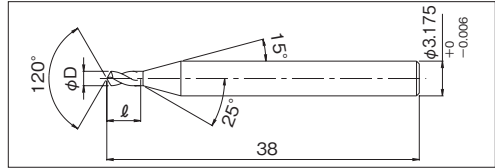

■ 微小径穴加工用のガイド穴専用ドリルです。

Special guide-hole drills for use in drilling small holes.

φ0.03~φ0.04は首逃げ2段形状です。

■ 穴位置・穴径精度の厳しい加工に最適です。

Most suitable for work that requires stringent hole position accuracy.

刃径公差：φD Tolerance

-0.005~-0.01 (≦φ0.09)

-0.01~-0.015 (≧φ0.1)

0.3≦φD≦0.95



単位 Unit : mm

型番 CODE NUMBER	径 φD	刃長 ℓ	全長 L	シャンク d	定価 ¥
ADPF31-0003	0.03	0.06	38	3.175	20,000
ADPF31-0004	0.04	0.08	38	3.175	17,340
ADPF31-0005	0.05	0.1	38	3.175	15,170
ADPF31-0006	0.06	0.1	38	3.175	12,840
ADPF31-0007	0.07	0.1	38	3.175	10,040
ADPF31-0008	0.08	0.1	38	3.175	8,990
ADPF31-0009	0.09	0.1	38	3.175	7,700
ADPF31-0010	0.1	0.2	38	3.175	7,000
ADPF31-0011	0.11	0.2	38	3.175	7,670
ADPF31-0012	0.12	0.2	38	3.175	7,670
ADPF31-0013	0.13	0.2	38	3.175	7,670
ADPF31-0014	0.14	0.2	38	3.175	7,670
ADPF31-0015	0.15	0.2	38	3.175	7,000
ADPF31-0016	0.16	0.3	38	3.175	7,670
ADPF31-0017	0.17	0.3	38	3.175	7,670
ADPF31-0018	0.18	0.3	38	3.175	7,670
ADPF31-0019	0.19	0.3	38	3.175	7,670
ADPF31-0020	0.2	0.4	38	3.175	6,300
ADPF31-0021	0.21	0.4	38	3.175	7,000
ADPF31-0022	0.22	0.4	38	3.175	7,000
ADPF31-0023	0.23	0.4	38	3.175	7,000
ADPF31-0024	0.24	0.4	38	3.175	7,000
ADPF31-0025	0.25	0.4	38	3.175	6,300
ADPF31-0026	0.26	0.5	38	3.175	7,000
ADPF31-0027	0.27	0.5	38	3.175	7,000
ADPF31-0028	0.28	0.5	38	3.175	7,000
ADPF31-0029	0.29	0.5	38	3.175	7,000
ADPF31-0030	0.3	0.6	38	3.175	6,200
ADPF31-0035	0.35	0.6	38	3.175	6,200
ADPF31-0040	0.4	0.6	38	3.175	6,200
ADPF31-0045	0.45	0.6	38	3.175	6,200

型番 CODE NUMBER	径 φD	刃長 ℓ	全長 L	シャンク d	定価 ¥
ADPF31-0050	0.5	1	38	3.175	5,600
ADPF31-0055	0.55	1	38	3.175	6,200
ADPF31-0060	0.6	1	38	3.175	6,200
ADPF31-0065	0.65	1	38	3.175	6,200
ADPF31-0070	0.7	1.2	38	3.175	6,200
ADPF31-0075	0.75	1.2	38	3.175	6,200
ADPF31-0080	0.8	1.2	38	3.175	6,200
ADPF31-0085	0.85	1.2	38	3.175	6,200
ADPF31-0090	0.9	1.8	38	3.175	6,200
ADPF31-0095	0.95	1.8	38	3.175	6,200
ADPF31-0100	1	2(1.8)	38	3.175	5,600
ADPF31-0110	1.1	2	38	3.175	6,200
ADPF31-0120	1.2	2	38	3.175	6,200
ADPF31-0130	1.3	3	38	3.175	6,200
ADPF31-0140	1.4	3	38	3.175	6,200
ADPF31-0150	1.5	3(2.5)	38	3.175	5,600
ADPF31-0160	1.6	3	38	3.175	6,200
ADPF31-0170	1.7	3	38	3.175	6,200
ADPF31-0180	1.8	4	38	3.175	6,200
ADPF31-0190	1.9	4	38	3.175	6,200
ADPF31-0200	2	4(2.5)	38	3.175	5,600
ADPF31-0210	2.1	4	38	3.175	6,200
ADPF31-0220	2.2	4	38	3.175	6,200
ADPF31-0230	2.3	5	38	3.175	6,200
ADPF31-0240	2.4	5	38	3.175	6,200
ADPF31-0250	2.5	5(3)	38	3.175	5,600
ADPF31-0260	2.6	5	38	3.175	6,200
ADPF31-0270	2.7	5	38	3.175	6,200
ADPF31-0280	2.8	5	38	3.175	6,200
ADPF31-0290	2.9	5	38	3.175	6,200
ADPF31-0300	3	5(3)	38	3.175	5,600

※ ( ) 内刃長は旧仕様となります。

先端120°ガイド穴専用ドリル Guide Hole Drill

# NCポインティングドリル〈3.175mmシャンク〉

NC Pointing Drill with 120° point angle and 3.175mm(1/8") shank

## V-ADPF31 鋼材用, TiAlNコーティング

for Ferrous material, TiAlN Coating

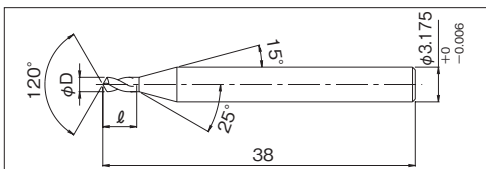

■ 微小径穴加工用のガイド穴専用ドリルです。

Special guide-hole drills for use in drilling small holes.

■ 穴位置・穴径精度の厳しい加工に最適です。

Most suitable for work that requires stringent hole position accuracy.

■ TiAlNコーティングにより耐摩耗性が向上、長寿命加工を実現します。

TiAlN coated improves wear resistance and extends its toll life.

φ0.03~φ0.04は首逃げ2段形状です。

刃径公差: φD Tolerance

-0.002~-0.009 (φ0.03~φ0.09)

-0.007~-0.014 (φ0.1~φ0.29)

-0.005~-0.013 (φ0.3~φ3)



0.3 ≤ φD ≤ 0.95

単位 Unit : mm

型番 CODE NUMBER	径 φD	刃長 ℓ	全長 L	シャンク d	定価 ¥
V-ADPF31-0003	0.03	0.06	38	3.175	22,730
V-ADPF31-0004	0.04	0.08	38	3.175	20,070
V-ADPF31-0005	0.05	0.1	38	3.175	17,900
V-ADPF31-0006	0.06	0.1	38	3.175	15,570
V-ADPF31-0007	0.07	0.1	38	3.175	11,930
V-ADPF31-0008	0.08	0.1	38	3.175	10,900
V-ADPF31-0009	0.09	0.1	38	3.175	9,600
V-ADPF31-0010	0.1	0.2	38	3.175	8,400
V-ADPF31-0011	0.11	0.2	38	3.175	9,070
V-ADPF31-0012	0.12	0.2	38	3.175	9,070
V-ADPF31-0013	0.13	0.2	38	3.175	9,070
V-ADPF31-0014	0.14	0.2	38	3.175	9,070
V-ADPF31-0015	0.15	0.2	38	3.175	8,400
V-ADPF31-0016	0.16	0.3	38	3.175	9,070
V-ADPF31-0017	0.17	0.3	38	3.175	9,070
V-ADPF31-0018	0.18	0.3	38	3.175	9,070
V-ADPF31-0019	0.19	0.3	38	3.175	9,070
V-ADPF31-0020	0.2	0.4	38	3.175	7,700
V-ADPF31-0021	0.21	0.4	38	3.175	8,330
V-ADPF31-0022	0.22	0.4	38	3.175	8,330
V-ADPF31-0023	0.23	0.4	38	3.175	8,330
V-ADPF31-0024	0.24	0.4	38	3.175	8,330
V-ADPF31-0025	0.25	0.4	38	3.175	7,700
V-ADPF31-0026	0.26	0.5	38	3.175	8,330
V-ADPF31-0027	0.27	0.5	38	3.175	8,330
V-ADPF31-0028	0.28	0.5	38	3.175	8,330
V-ADPF31-0029	0.29	0.5	38	3.175	8,330
V-ADPF31-0030	0.3	0.6	38	3.175	7,400
V-ADPF31-0035	0.35	0.6	38	3.175	7,400
V-ADPF31-0040	0.4	0.6	38	3.175	7,400
V-ADPF31-0045	0.45	0.6	38	3.175	7,400

型番 CODE NUMBER	径 φD	刃長 ℓ	全長 L	シャンク d	定価 ¥
V-ADPF31-0050	0.5	1	38	3.175	6,730
V-ADPF31-0055	0.55	1	38	3.175	7,400
V-ADPF31-0060	0.6	1	38	3.175	7,400
V-ADPF31-0065	0.65	1	38	3.175	7,400
V-ADPF31-0070	0.7	1.2	38	3.175	7,400
V-ADPF31-0075	0.75	1.2	38	3.175	7,400
V-ADPF31-0080	0.8	1.2	38	3.175	7,400
V-ADPF31-0085	0.85	1.2	38	3.175	7,400
V-ADPF31-0090	0.9	1.8	38	3.175	7,400
V-ADPF31-0095	0.95	1.8	38	3.175	7,400
V-ADPF31-0100	1	2(1.8)	38	3.175	6,730
V-ADPF31-0110	1.1	2	38	3.175	7,400
V-ADPF31-0120	1.2	2	38	3.175	7,400
V-ADPF31-0130	1.3	3	38	3.175	7,400
V-ADPF31-0140	1.4	3	38	3.175	7,400
V-ADPF31-0150	1.5	3(2.5)	38	3.175	6,730
V-ADPF31-0160	1.6	3	38	3.175	7,400
V-ADPF31-0170	1.7	3	38	3.175	7,400
V-ADPF31-0180	1.8	4	38	3.175	7,400
V-ADPF31-0190	1.9	4	38	3.175	7,400
V-ADPF31-0200	2	4(2.5)	38	3.175	6,730
V-ADPF31-0210	2.1	4	38	3.175	7,400
V-ADPF31-0220	2.2	4	38	3.175	7,400
V-ADPF31-0230	2.3	5	38	3.175	7,400
V-ADPF31-0240	2.4	5	38	3.175	7,400
V-ADPF31-0250	2.5	5(3)	38	3.175	6,730
V-ADPF31-0260	2.6	5	38	3.175	7,400
V-ADPF31-0270	2.7	5	38	3.175	7,400
V-ADPF31-0280	2.8	5	38	3.175	7,400
V-ADPF31-0290	2.9	5	38	3.175	7,400
V-ADPF31-0300	3	5(3)	38	3.175	6,730

※ ( ) 内刃長は旧仕様となります。



先端120° ガイド穴専用ドリル Guide Hole Drill

## NCポインティングドリル

NC Pointing Drill with 120° point angle

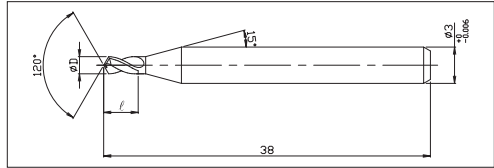
ADPN30 非鉄・樹脂用  
for Non-Ferrous & Resin

■ 微小径穴加工用のガイド穴専用ドリルです。  
Special guide-hole drills for use in drilling small holes.

■ 穴位置・穴径精度の厳しい加工に最適です。  
Most suitable for work that requires stringent hole position accuracy.

φ0.03～φ0.04は首逃げ2段形状です。

刃径公差：φD Tolerance

-0.005～-0.01 (≦φ0.09)

-0.01～-0.015 (≧φ0.1)

0.3≦φD≦0.95



単位 Unit : mm

型番 CODE NUMBER	径 φD	刃長 ℓ	全長 L	シャンク d	定価 ¥
ADPN30-0003	0.03	0.06	38	3	20,000
ADPN30-0004	0.04	0.08	38	3	17,340
ADPN30-0005	0.05	0.1	38	3	15,170
ADPN30-0006	0.06	0.1	38	3	12,840
ADPN30-0007	0.07	0.1	38	3	10,040
ADPN30-0008	0.08	0.1	38	3	8,990
ADPN30-0009	0.09	0.1	38	3	7,700
ADPN30-0010	0.1	0.2	38	3	7,000
ADPN30-0011	0.11	0.2	38	3	7,670
ADPN30-0012	0.12	0.2	38	3	7,670
ADPN30-0013	0.13	0.2	38	3	7,670
ADPN30-0014	0.14	0.2	38	3	7,670
ADPN30-0015	0.15	0.2	38	3	7,000
ADPN30-0016	0.16	0.3	38	3	7,670
ADPN30-0017	0.17	0.3	38	3	7,670
ADPN30-0018	0.18	0.3	38	3	7,670
ADPN30-0019	0.19	0.3	38	3	7,670
ADPN30-0020	0.2	0.4	38	3	6,300
ADPN30-0021	0.21	0.4	38	3	7,000
ADPN30-0022	0.22	0.4	38	3	7,000
ADPN30-0023	0.23	0.4	38	3	7,000
ADPN30-0024	0.24	0.4	38	3	7,000
ADPN30-0025	0.25	0.4	38	3	6,300
ADPN30-0026	0.26	0.5	38	3	7,000
ADPN30-0027	0.27	0.5	38	3	7,000
ADPN30-0028	0.28	0.5	38	3	7,000
ADPN30-0029	0.29	0.5	38	3	7,000
ADPN30-0030	0.3	0.6	38	3	6,200
ADPN30-0035	0.35	0.6	38	3	6,200
ADPN30-0040	0.4	0.6	38	3	6,200
ADPN30-0045	0.45	0.6	38	3	6,200

型番 CODE NUMBER	径 φD	刃長 ℓ	全長 L	シャンク d	定価 ¥
ADPN30-0050	0.5	1	38	3	5,600
ADPN30-0055	0.55	1	38	3	6,200
ADPN30-0060	0.6	1	38	3	6,200
ADPN30-0065	0.65	1	38	3	6,200
ADPN30-0070	0.7	1.2	38	3	6,200
ADPN30-0075	0.75	1.2	38	3	6,200
ADPN30-0080	0.8	1.2	38	3	6,200
ADPN30-0085	0.85	1.2	38	3	6,200
ADPN30-0090	0.9	1.8	38	3	6,200
ADPN30-0095	0.95	1.8	38	3	6,200
ADPN30-0100	1	2(1.8)	38	3	5,600
ADPN30-0110	1.1	2	38	3	6,200
ADPN30-0120	1.2	2	38	3	6,200
ADPN30-0130	1.3	3	38	3	6,200
ADPN30-0140	1.4	3	38	3	6,200
ADPN30-0150	1.5	3(2.5)	38	3	5,600
ADPN30-0160	1.6	3	38	3	6,200
ADPN30-0170	1.7	3	38	3	6,200
ADPN30-0180	1.8	4	38	3	6,200
ADPN30-0190	1.9	4	38	3	6,200
ADPN30-0200	2	4(2.5)	38	3	5,600
ADPN30-0210	2.1	4	38	3	6,200
ADPN30-0220	2.2	4	38	3	6,200
ADPN30-0230	2.3	5	38	3	6,200
ADPN30-0240	2.4	5	38	3	6,200
ADPN30-0250	2.5	5(3)	38	3	5,600
ADPN30-0260	2.6	5	38	3	6,200
ADPN30-0270	2.7	5	38	3	6,200
ADPN30-0280	2.8	5	38	3	6,200
ADPN30-0290	2.9	5	38	3	6,200
ADPN30-0300	3	5(3)	38	3	5,600

※ ( ) 内刃長は仕仕様となります。

先端120° ガイド穴専用ドリル Guide Hole Drill

# NCポインティングドリル〈3.175mmシャンク〉

NC Pointing Drill with 120° point angle and 3.175mm(1/8") shank

## ADPN31 非鉄・樹脂用 for Non-Ferrous & Resin

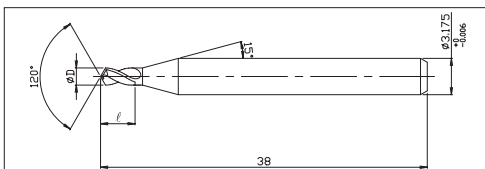

■ 微小径穴加工用のガイド穴専用ドリルです。

Special guide-hole drills for use in drilling small holes.

■ 穴位置・穴径精度の厳しい加工に最適です。

Most suitable for work that requires stringent hole position accuracy.

φ0.03~φ0.04は首逃げ2段形状です。

刃径公差：φD Tolerance

-0.005~-0.01 (≦φ0.09)

-0.01~-0.015 (≧φ0.1)

0.3≦φD≦0.95



単位 Unit : mm

型番 CODE NUMBER	径 φD	刃長 ℓ	全長 L	シャンク d	定価 ¥
ADPN31-0003	0.03	0.06	38	3.175	20,000
ADPN31-0004	0.04	0.08	38	3.175	17,340
ADPN31-0005	0.05	0.1	38	3.175	15,170
ADPN31-0006	0.06	0.1	38	3.175	12,840
ADPN31-0007	0.07	0.1	38	3.175	10,040
ADPN31-0008	0.08	0.1	38	3.175	8,990
ADPN31-0009	0.09	0.1	38	3.175	7,700
ADPN31-0010	0.1	0.2	38	3.175	7,000
ADPN31-0011	0.11	0.2	38	3.175	7,670
ADPN31-0012	0.12	0.2	38	3.175	7,670
ADPN31-0013	0.13	0.2	38	3.175	7,670
ADPN31-0014	0.14	0.2	38	3.175	7,670
ADPN31-0015	0.15	0.2	38	3.175	7,000
ADPN31-0016	0.16	0.3	38	3.175	7,670
ADPN31-0017	0.17	0.3	38	3.175	7,670
ADPN31-0018	0.18	0.3	38	3.175	7,670
ADPN31-0019	0.19	0.3	38	3.175	7,670
ADPN31-0020	0.2	0.4	38	3.175	6,300
ADPN31-0021	0.21	0.4	38	3.175	7,000
ADPN31-0022	0.22	0.4	38	3.175	7,000
ADPN31-0023	0.23	0.4	38	3.175	7,000
ADPN31-0024	0.24	0.4	38	3.175	7,000
ADPN31-0025	0.25	0.4	38	3.175	6,300
ADPN31-0026	0.26	0.5	38	3.175	7,000
ADPN31-0027	0.27	0.5	38	3.175	7,000
ADPN31-0028	0.28	0.5	38	3.175	7,000
ADPN31-0029	0.29	0.5	38	3.175	7,000
ADPN31-0030	0.3	0.6	38	3.175	6,200
ADPN31-0035	0.35	0.6	38	3.175	6,200
ADPN31-0040	0.4	0.6	38	3.175	6,200
ADPN31-0045	0.45	0.6	38	3.175	6,200

型番 CODE NUMBER	径 φD	刃長 ℓ	全長 L	シャンク d	定価 ¥
ADPN31-0050	0.5	1	38	3.175	5,600
ADPN31-0055	0.55	1	38	3.175	6,200
ADPN31-0060	0.6	1	38	3.175	6,200
ADPN31-0065	0.65	1	38	3.175	6,200
ADPN31-0070	0.7	1.2	38	3.175	6,200
ADPN31-0075	0.75	1.2	38	3.175	6,200
ADPN31-0080	0.8	1.2	38	3.175	6,200
ADPN31-0085	0.85	1.2	38	3.175	6,200
ADPN31-0090	0.9	1.8	38	3.175	6,200
ADPN31-0095	0.95	1.8	38	3.175	6,200
ADPN31-0100	1	2(1.8)	38	3.175	5,600
ADPN31-0110	1.1	2	38	3.175	6,200
ADPN31-0120	1.2	2	38	3.175	6,200
ADPN31-0130	1.3	3	38	3.175	6,200
ADPN31-0140	1.4	3	38	3.175	6,200
ADPN31-0150	1.5	3(2.5)	38	3.175	5,600
ADPN31-0160	1.6	3	38	3.175	6,200
ADPN31-0170	1.7	3	38	3.175	6,200
ADPN31-0180	1.8	4	38	3.175	6,200
ADPN31-0190	1.9	4	38	3.175	6,200
ADPN31-0200	2	4(2.5)	38	3.175	5,600
ADPN31-0210	2.1	4	38	3.175	6,200
ADPN31-0220	2.2	4	38	3.175	6,200
ADPN31-0230	2.3	5	38	3.175	6,200
ADPN31-0240	2.4	5	38	3.175	6,200
ADPN31-0250	2.5	5(3)	38	3.175	5,600
ADPN31-0260	2.6	5	38	3.175	6,200
ADPN31-0270	2.7	5	38	3.175	6,200
ADPN31-0280	2.8	5	38	3.175	6,200
ADPN31-0290	2.9	5	38	3.175	6,200
ADPN31-0300	3	5(3)	38	3.175	5,600

※ ( ) 内刃長は旧仕様となります。

先端90° ガイド穴専用ドリル Guide Hole Drill

## NCポインティングドリル

NC Pointing Drill with 90° point angle

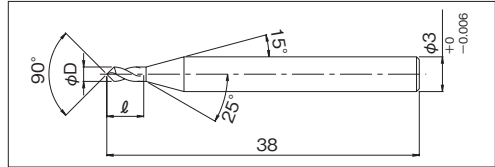
ADPF309 鋼材用  
for Ferrous material

■ 微小径穴加工用のガイド穴専用ドリルです。

Special guide-hole drills for use in drilling small holes.

■ 穴位置・穴径精度の厳しい加工に最適です。

Most suitable for work that requires stringent hole position accuracy.

φ0.03~φ0.04は首逃げ2段形状です。

刃径公差：φ D Tolerance

-0.005~-0.01 (≦φ 0.09)

-0.01~-0.015 (≧φ 0.1)

0.3≦φD≦0.95



単位 Unit : mm

型番 CODE NUMBER	径 φD	刃長 ℓ	全長 L	シャンク d	定価 ¥
ADPF309-0003	0.03	0.06	38	3	20,000
ADPF309-0004	0.04	0.08	38	3	17,340
ADPF309-0005	0.05	0.1	38	3	15,170
ADPF309-0006	0.06	0.1	38	3	12,840
ADPF309-0007	0.07	0.1	38	3	10,040
ADPF309-0008	0.08	0.1	38	3	8,990
ADPF309-0009	0.09	0.1	38	3	7,700
ADPF309-0010	0.1	0.2	38	3	7,000
ADPF309-0011	0.11	0.2	38	3	7,670
ADPF309-0012	0.12	0.2	38	3	7,670
ADPF309-0013	0.13	0.2	38	3	7,670
ADPF309-0014	0.14	0.2	38	3	7,670
ADPF309-0015	0.15	0.2	38	3	7,000
ADPF309-0016	0.16	0.3	38	3	7,670
ADPF309-0017	0.17	0.3	38	3	7,670
ADPF309-0018	0.18	0.3	38	3	7,670
ADPF309-0019	0.19	0.3	38	3	7,670
ADPF309-0020	0.2	0.4	38	3	6,300
ADPF309-0021	0.21	0.4	38	3	7,000
ADPF309-0022	0.22	0.4	38	3	7,000
ADPF309-0023	0.23	0.4	38	3	7,000
ADPF309-0024	0.24	0.4	38	3	7,000
ADPF309-0025	0.25	0.4	38	3	6,300
ADPF309-0026	0.26	0.5	38	3	7,000
ADPF309-0027	0.27	0.5	38	3	7,000
ADPF309-0028	0.28	0.5	38	3	7,000
ADPF309-0029	0.29	0.5	38	3	7,000
ADPF309-0030	0.3	0.6	38	3	6,200
ADPF309-0035	0.35	0.6	38	3	6,200
ADPF309-0040	0.4	0.6	38	3	6,200
ADPF309-0045	0.45	0.6	38	3	6,200

型番 CODE NUMBER	径 φD	刃長 ℓ	全長 L	シャンク d	定価 ¥
ADPF309-0050	0.5	1	38	3	5,600
ADPF309-0055	0.55	1	38	3	6,200
ADPF309-0060	0.6	1	38	3	6,200
ADPF309-0065	0.65	1	38	3	6,200
ADPF309-0070	0.7	1.2	38	3	6,200
ADPF309-0075	0.75	1.2	38	3	6,200
ADPF309-0080	0.8	1.2	38	3	6,200
ADPF309-0085	0.85	1.2	38	3	6,200
ADPF309-0090	0.9	1.8	38	3	6,200
ADPF309-0095	0.95	1.8	38	3	6,200
ADPF309-0100	1	2(1.8)	38	3	5,600
ADPF309-0110	1.1	2	38	3	6,200
ADPF309-0120	1.2	2	38	3	6,200
ADPF309-0130	1.3	3	38	3	6,200
ADPF309-0140	1.4	3	38	3	6,200
ADPF309-0150	1.5	3(2.5)	38	3	5,600
ADPF309-0160	1.6	3	38	3	6,200
ADPF309-0170	1.7	3	38	3	6,200
ADPF309-0180	1.8	4	38	3	6,200
ADPF309-0190	1.9	4	38	3	6,200
ADPF309-0200	2	4(2.5)	38	3	5,600
ADPF309-0210	2.1	4	38	3	6,200
ADPF309-0220	2.2	4	38	3	6,200
ADPF309-0230	2.3	5	38	3	6,200
ADPF309-0240	2.4	5	38	3	6,200
ADPF309-0250	2.5	5(3)	38	3	5,600
ADPF309-0260	2.6	5	38	3	6,200
ADPF309-0270	2.7	5	38	3	6,200
ADPF309-0280	2.8	5	38	3	6,200
ADPF309-0290	2.9	5	38	3	6,200
ADPF309-0300	3	5(3)	38	3	5,600

※ ( ) 内刃長は旧仕様となります。

先端90° ガイド穴専用ドリル Guide Hole Drill

# NCポインティングドリル

NC Pointing Drill with 90° point angle

## V-ADPF309 鋼材用, TiAlNコーティング

for Ferrous material, TiAlN Coating

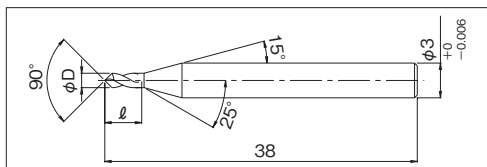

■ 微小径穴加工用のガイド穴専用ドリルです。  
Special guide-hole drills for use in drilling small holes.

■ 穴位置・穴径精度の厳しい加工に最適です。  
Most suitable for work that requires stringent hole position accuracy.

■ TiAlNコーティングにより耐摩耗性が向上、長寿命加工を実現します。  
TiAlN coated improves wear resistance and extends its toll life.

φ0.03~φ0.04は首逃げ2段形状です。

刃径公差: φD Tolerance

-0.002~-0.009 (φ0.03~φ0.09)

-0.007~-0.014 (φ0.1~φ0.29)

-0.005~-0.013 (φ0.3~φ3)



0.3 ≤ φD ≤ 0.95

単位 Unit : mm

型番 CODE NUMBER	径 φD	刃長 ℓ	全長 L	シャンク d	定価 ¥
V-ADPF309-0003	0.03	0.06	38	3	22,730
V-ADPF309-0004	0.04	0.08	38	3	20,070
V-ADPF309-0005	0.05	0.1	38	3	17,900
V-ADPF309-0006	0.06	0.1	38	3	15,570
V-ADPF309-0007	0.07	0.1	38	3	11,930
V-ADPF309-0008	0.08	0.1	38	3	10,900
V-ADPF309-0009	0.09	0.1	38	3	9,600
V-ADPF309-0010	0.1	0.2	38	3	8,400
V-ADPF309-0011	0.11	0.2	38	3	9,070
V-ADPF309-0012	0.12	0.2	38	3	9,070
V-ADPF309-0013	0.13	0.2	38	3	9,070
V-ADPF309-0014	0.14	0.2	38	3	9,070
V-ADPF309-0015	0.15	0.2	38	3	8,400
V-ADPF309-0016	0.16	0.3	38	3	9,070
V-ADPF309-0017	0.17	0.3	38	3	9,070
V-ADPF309-0018	0.18	0.3	38	3	9,070
V-ADPF309-0019	0.19	0.3	38	3	9,070
V-ADPF309-0020	0.2	0.4	38	3	7,700
V-ADPF309-0021	0.21	0.4	38	3	8,330
V-ADPF309-0022	0.22	0.4	38	3	8,330
V-ADPF309-0023	0.23	0.4	38	3	8,330
V-ADPF309-0024	0.24	0.4	38	3	8,330
V-ADPF309-0025	0.25	0.4	38	3	7,700
V-ADPF309-0026	0.26	0.5	38	3	8,330
V-ADPF309-0027	0.27	0.5	38	3	8,330
V-ADPF309-0028	0.28	0.5	38	3	8,330
V-ADPF309-0029	0.29	0.5	38	3	8,330
V-ADPF309-0030	0.3	0.6	38	3	7,400
V-ADPF309-0035	0.35	0.6	38	3	7,400
V-ADPF309-0040	0.4	0.6	38	3	7,400
V-ADPF309-0045	0.45	0.6	38	3	7,400

型番 CODE NUMBER	径 φD	刃長 ℓ	全長 L	シャンク d	定価 ¥
V-ADPF309-0050	0.5	1	38	3	6,730
V-ADPF309-0055	0.55	1	38	3	7,400
V-ADPF309-0060	0.6	1	38	3	7,400
V-ADPF309-0065	0.65	1	38	3	7,400
V-ADPF309-0070	0.7	1.2	38	3	7,400
V-ADPF309-0075	0.75	1.2	38	3	7,400
V-ADPF309-0080	0.8	1.2	38	3	7,400
V-ADPF309-0085	0.85	1.2	38	3	7,400
V-ADPF309-0090	0.9	1.8	38	3	7,400
V-ADPF309-0095	0.95	1.8	38	3	7,400
V-ADPF309-0100	1	2(1.8)	38	3	6,730
V-ADPF309-0110	1.1	2	38	3	7,400
V-ADPF309-0120	1.2	2	38	3	7,400
V-ADPF309-0130	1.3	3	38	3	7,400
V-ADPF309-0140	1.4	3	38	3	7,400
V-ADPF309-0150	1.5	3(2.5)	38	3	6,730
V-ADPF309-0160	1.6	3	38	3	7,400
V-ADPF309-0170	1.7	3	38	3	7,400
V-ADPF309-0180	1.8	4	38	3	7,400
V-ADPF309-0190	1.9	4	38	3	7,400
V-ADPF309-0200	2	4(2.5)	38	3	6,730
V-ADPF309-0210	2.1	4	38	3	7,400
V-ADPF309-0220	2.2	4	38	3	7,400
V-ADPF309-0230	2.3	5	38	3	7,400
V-ADPF309-0240	2.4	5	38	3	7,400
V-ADPF309-0250	2.5	5(3)	38	3	6,730
V-ADPF309-0260	2.6	5	38	3	7,400
V-ADPF309-0270	2.7	5	38	3	7,400
V-ADPF309-0280	2.8	5	38	3	7,400
V-ADPF309-0290	2.9	5	38	3	7,400
V-ADPF309-0300	3	5(3)	38	3	6,730

※ ( ) 内刃長は旧仕様となります。

先端90° ガイド穴専用ドリル Guide Hole Drill

## NCポインティングドリル

NC Pointing Drill with 90° point angle

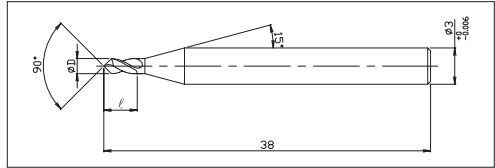
ADPN309 非鉄・樹脂用  
for Non-Ferrous & Resin

■ 微小径穴加工用のガイド穴専用ドリルです。  
Special guide-hole drills for use in drilling small holes.

φ0.03~φ0.04は首逃げ2段形状です。

■ 穴位置・穴径精度の厳しい加工に最適です。  
Most suitable for work that requires stringent hole position accuracy.

刃径公差：φD Tolerance

-0.005~-0.01 (≤φ0.09)  
-0.01~-0.015 (≥φ0.1)

0.3 ≤ φD ≤ 0.95



単位 Unit : mm

型番 CODE NUMBER	径 φD	刃長 ℓ	全長 L	シャンク d	定価 ¥
ADPN309-0003	0.03	0.06	38	3	20,000
ADPN309-0004	0.04	0.08	38	3	17,340
ADPN309-0005	0.05	0.1	38	3	15,170
ADPN309-0006	0.06	0.1	38	3	12,840
ADPN309-0007	0.07	0.1	38	3	10,040
ADPN309-0008	0.08	0.1	38	3	8,990
ADPN309-0009	0.09	0.1	38	3	7,700
ADPN309-0010	0.1	0.2	38	3	7,000
ADPN309-0011	0.11	0.2	38	3	7,670
ADPN309-0012	0.12	0.2	38	3	7,670
ADPN309-0013	0.13	0.2	38	3	7,670
ADPN309-0014	0.14	0.2	38	3	7,670
ADPN309-0015	0.15	0.2	38	3	7,000
ADPN309-0016	0.16	0.3	38	3	7,670
ADPN309-0017	0.17	0.3	38	3	7,670
ADPN309-0018	0.18	0.3	38	3	7,670
ADPN309-0019	0.19	0.3	38	3	7,670
ADPN309-0020	0.2	0.4	38	3	6,300
ADPN309-0021	0.21	0.4	38	3	7,000
ADPN309-0022	0.22	0.4	38	3	7,000
ADPN309-0023	0.23	0.4	38	3	7,000
ADPN309-0024	0.24	0.4	38	3	7,000
ADPN309-0025	0.25	0.4	38	3	6,300
ADPN309-0026	0.26	0.5	38	3	7,000
ADPN309-0027	0.27	0.5	38	3	7,000
ADPN309-0028	0.28	0.5	38	3	7,000
ADPN309-0029	0.29	0.5	38	3	7,000
ADPN309-0030	0.3	0.6	38	3	6,200
ADPN309-0035	0.35	0.6	38	3	6,200
ADPN309-0040	0.4	0.6	38	3	6,200
ADPN309-0045	0.45	0.6	38	3	6,200

型番 CODE NUMBER	径 φD	刃長 ℓ	全長 L	シャンク d	定価 ¥
ADPN309-0050	0.5	1	38	3	5,600
ADPN309-0055	0.55	1	38	3	6,200
ADPN309-0060	0.6	1	38	3	6,200
ADPN309-0065	0.65	1	38	3	6,200
ADPN309-0070	0.7	1.2	38	3	6,200
ADPN309-0075	0.75	1.2	38	3	6,200
ADPN309-0080	0.8	1.2	38	3	6,200
ADPN309-0085	0.85	1.2	38	3	6,200
ADPN309-0090	0.9	1.8	38	3	6,200
ADPN309-0095	0.95	1.8	38	3	6,200
ADPN309-0100	1	2(1.8)	38	3	5,600
ADPN309-0110	1.1	2	38	3	6,200
ADPN309-0120	1.2	2	38	3	6,200
ADPN309-0130	1.3	3	38	3	6,200
ADPN309-0140	1.4	3	38	3	6,200
ADPN309-0150	1.5	3(2.5)	38	3	5,600
ADPN309-0160	1.6	3	38	3	6,200
ADPN309-0170	1.7	3	38	3	6,200
ADPN309-0180	1.8	4	38	3	6,200
ADPN309-0190	1.9	4	38	3	6,200
ADPN309-0200	2	4(2.5)	38	3	5,600
ADPN309-0210	2.1	4	38	3	6,200
ADPN309-0220	2.2	4	38	3	6,200
ADPN309-0230	2.3	5	38	3	6,200
ADPN309-0240	2.4	5	38	3	6,200
ADPN309-0250	2.5	5(3)	38	3	5,600
ADPN309-0260	2.6	5	38	3	6,200
ADPN309-0270	2.7	5	38	3	6,200
ADPN309-0280	2.8	5	38	3	6,200
ADPN309-0290	2.9	5	38	3	6,200
ADPN309-0300	3	5(3)	38	3	5,600

※ ( ) 内刃長は旧仕様となります。

小径ローソク型ドリル

# スイープカットドリル〈ルーマタイプ〉

Sweep Cut Drill (3mm shank)

## ASWR



非鉄・樹脂用  
for Non-Ferrous & Resin

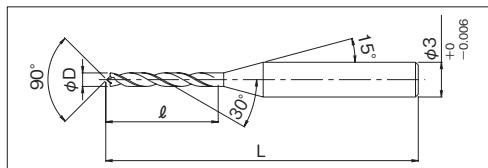

■ 貫通穴の抜けバリを大幅に削減します。

Leaves a cleaner hole edge minimizing exit burrs remarkably.

■ 穴曲がりを抑制します。

Prevents off-angle hole.

刃径公差: +0~-0.005

φD Tolerance



単位 Unit : mm

型番 CODE NUMBER	径 φD	刃長 ℓ	全長 L	シャンク d	定価 ¥
ASWR-0010	0.1	1.2	38	3	10,430
ASWR-0011	0.11	1.2	38	3	9,940
ASWR-0012	0.12	1.4	38	3	9,940
ASWR-0013	0.13	1.4	38	3	9,940
ASWR-0014	0.14	1.4	38	3	9,940
ASWR-0015	0.15	1.8	38	3	9,700
ASWR-0016	0.16	1.8	38	3	9,700
ASWR-0017	0.17	1.8	38	3	9,700
ASWR-0018	0.18	2.1	38	3	9,700
ASWR-0019	0.19	2.1	38	3	9,700
ASWR-0020	0.2	2.4	38	3	9,000
ASWR-0021	0.21	2.4	38	3	9,000
ASWR-0022	0.22	2.6	38	3	9,000
ASWR-0023	0.23	2.6	38	3	9,000
ASWR-0024	0.24	2.6	38	3	9,000
ASWR-0025	0.25	3	38	3	8,270
ASWR-0026	0.26	3	38	3	8,270
ASWR-0027	0.27	3	38	3	8,270
ASWR-0028	0.28	3.3	38	3	8,270
ASWR-0029	0.29	3.3	38	3	8,270
ASWR-0030	0.3	5	38	3	7,870
ASWR-0035	0.35	5	38	3	7,870
ASWR-0040	0.4	6	38	3	7,870
ASWR-0045	0.45	6	38	3	7,870
ASWR-0050	0.5	6	38	3	7,870
ASWR-0055	0.55	6	38	3	7,870
ASWR-0060	0.6	7	38	3	7,870
ASWR-0065	0.65	7	38	3	7,870

型番 CODE NUMBER	径 φD	刃長 ℓ	全長 L	シャンク d	定価 ¥
ASWR-0070	0.7	8	38	3	7,870
ASWR-0075	0.75	8	38	3	7,870
ASWR-0080	0.8	8	38	3	7,870
ASWR-0085	0.85	8	38	3	7,870
ASWR-0090	0.9	8	38	3	7,870
ASWR-0095	0.95	8	38	3	7,870
ASWR-0100	1	10	38	3	7,730
ASWR-0110	1.1	10	38	3	7,730
ASWR-0120	1.2	10	38	3	7,730
ASWR-0130	1.3	10	38	3	7,730
ASWR-0140	1.4	10	38	3	7,730
ASWR-0150	1.5	15	45	3	8,730
ASWR-0160	1.6	15	45	3	8,730
ASWR-0170	1.7	15	45	3	8,730
ASWR-0180	1.8	15	45	3	8,730
ASWR-0190	1.9	15	45	3	8,730
ASWR-0200	2	22	50	3	9,370
ASWR-0210	2.1	22	50	3	9,370
ASWR-0220	2.2	22	50	3	9,370
ASWR-0230	2.3	22	50	3	9,370
ASWR-0240	2.4	22	50	3	9,370
ASWR-0250	2.5	22	50	3	9,370
ASWR-0260	2.6	22	50	3	9,370
ASWR-0270	2.7	25	50	3	9,370
ASWR-0280	2.8	25	50	3	9,370
ASWR-0290	2.9	25	50	3	9,370
ASWR-0300	3	25	50	3	9,370



# 微小径ソリッドドリル ACDR-9000

Miniature Micro Drill ACDR-9000

特定代理店在庫品

## ACDR-9000

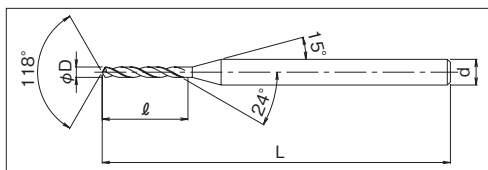

■ 高精度細穴加工用ドリルです。  
Best for drilling precision small holes.

刃径公差: +0~-0.003  
 $\phi D$  Tolerance



単位 Unit : mm

型番 CODE NUMBER	径 $\phi D$	刃長 $\ell$	全長 L	シャンク d
ACDR-9001.0	0.1	0.7	30	1
ACDR-9001.1	0.11	0.7	30	1
ACDR-9001.2	0.12	0.8	30	1
ACDR-9001.3	0.13	0.9	30	1
ACDR-9001.4	0.14	1	30	1
ACDR-9001.5	0.15	1.1	30	1
ACDR-9001.6	0.16	1.2	30	1
ACDR-9001.7	0.17	1.3	30	1
ACDR-9001.8	0.18	1.4	30	1
ACDR-9001.9	0.19	1.5	30	1
ACDR-9002.0	0.2	1.7	30	1
ACDR-9002.1	0.21	1.8	30	1
ACDR-9002.2	0.22	1.8	30	1
ACDR-9002.3	0.23	1.9	30	1
ACDR-9002.4	0.24	1.9	30	1
ACDR-9002.5	0.25	2	30	1
ACDR-9002.6	0.26	2	30	1
ACDR-9002.7	0.27	2	30	1
ACDR-9002.8	0.28	2.2	30	1
ACDR-9002.9	0.29	2.2	30	1
ACDR-9003.0	0.3	2.4	30	1
ACDR-9003.1	0.31	2.5	30	1
ACDR-9003.2	0.32	2.7	30	1
ACDR-9003.3	0.33	2.7	30	1
ACDR-9003.4	0.34	2.7	30	1
ACDR-9003.5	0.35	2.7	30	1

型番 CODE NUMBER	径 $\phi D$	刃長 $\ell$	全長 L	シャンク d
ACDR-9003.6	0.36	2.9	30	1
ACDR-9003.7	0.37	2.9	30	1
ACDR-9003.8	0.38	3	30	1
ACDR-9003.9	0.39	3	30	1
ACDR-9004.0	0.4	3	30	1
ACDR-9004.1	0.41	3.2	30	1
ACDR-9004.2	0.42	3.3	30	1
ACDR-9004.3	0.43	3.3	30	1
ACDR-9004.4	0.44	3.5	30	1
ACDR-9004.5	0.45	3.5	30	1
ACDR-9004.6	0.46	3.6	30	1
ACDR-9004.7	0.47	3.6	30	1
ACDR-9004.8	0.48	3.8	30	1
ACDR-9004.9	0.49	3.8	30	1
ACDR-9005.0	0.5	4.2	30	1
ACDR-9005.1	0.51	4.2	30	1
ACDR-9005.2	0.52	4.2	30	1
ACDR-9005.3	0.53	4.2	30	1
ACDR-9005.4	0.54	4.2	30	1
ACDR-9005.5	0.55	4.2	30	1
ACDR-9005.6	0.56	4.2	30	1
ACDR-9005.7	0.57	4.2	30	1
ACDR-9005.8	0.58	4.2	30	1
ACDR-9005.9	0.59	4.2	30	1
ACDR-9006.0	0.6	4.7	30	1
ACDR-9006.1	0.61	4.7	30	1

特定在庫品  
Stocked by Specific Distributor





# コーティングルーマドリル ショート刃

Coated Micro Drill, Short Flute

特定代理店在庫品

## CX-ADRS

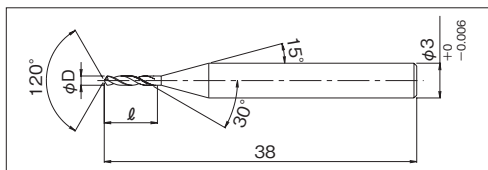

■ 軟鋼難削材から高硬度鋼まで幅広い対応が可能なコーティングドリルです。

Wide drilling application available from mild steel to hardened steel.

刃径公差：+0~-0.01

$\phi D$  Tolerance

単位 Unit : mm

型番 CODE NUMBER	径 $\phi D$	刃長 $l$	全長 L	シャンク d
CX-ADRS-0030	0.3	2.5	38	3
CX-ADRS-0035	0.35	2.5	38	3
CX-ADRS-0040	0.4	3	38	3
CX-ADRS-0045	0.45	3	38	3
CX-ADRS-0050	0.5	3	38	3
CX-ADRS-0055	0.55	3	38	3
CX-ADRS-0060	0.6	3	38	3
CX-ADRS-0065	0.65	4	38	3
CX-ADRS-0070	0.7	4	38	3
CX-ADRS-0075	0.75	4	38	3
CX-ADRS-0080	0.8	4	38	3
CX-ADRS-0085	0.85	4	38	3
CX-ADRS-0090	0.9	4	38	3
CX-ADRS-0095	0.95	4	38	3
CX-ADRS-0100	1	5	38	3



特定在庫品  
Stocked by Specific Distributor

# コーティングルーマドリル ロング刃

Coated Micro Drill, Long Flute

特定代理店在庫品

## CX-ADRL

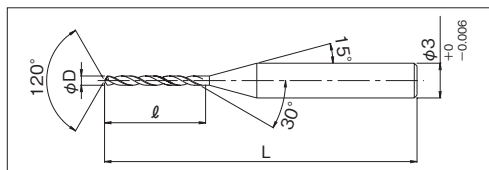

■ 軟鋼難削材から高硬度鋼まで幅広い対応が可能なコーティングドリルです。

Wide drilling application available from mild steel to hardened steel.

刃径公差：+0~-0.01

$\phi D$  Tolerance

単位 Unit : mm

型番 CODE NUMBER	径 $\phi D$	刃長 $\ell$	全長 $L$	シャンク $d$
CX-ADRL-0030	0.3	9	45	3
CX-ADRL-0035	0.35	10	45	3
CX-ADRL-0040	0.4	12	45	3
CX-ADRL-0045	0.45	12	45	3
CX-ADRL-0050	0.5	12	45	3
CX-ADRL-0055	0.55	12	45	3
CX-ADRL-0060	0.6	15	45	3
CX-ADRL-0065	0.65	15	45	3
CX-ADRL-0070	0.7	15	45	3
CX-ADRL-0075	0.75	15	45	3
CX-ADRL-0080	0.8	15	45	3
CX-ADRL-0085	0.85	15	45	3
CX-ADRL-0090	0.9	15	45	3
CX-ADRL-0095	0.95	15	45	3
CX-ADRL-0100	1	20	50	3



特別在庫品  
Stocked by Specific Distributor

# ATOM

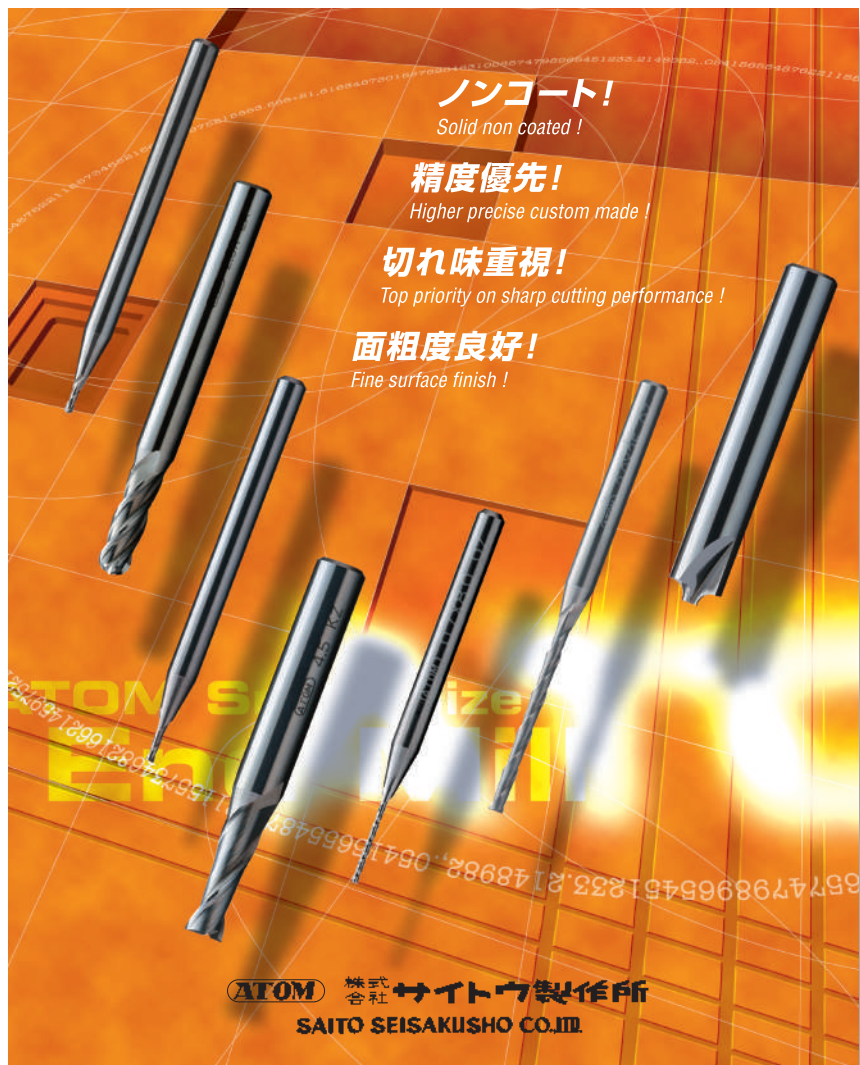

**ノンコート!**

*Solid non coated!*

**精度優先!**

*Higher precise custom made!*

**切れ味重視!**

*Top priority on sharp cutting performance!*

**面粗度良好!**

*Fine surface finish!*

**ATOM** 株式会社 **サイトウ製作所**  
**SAITOU SEISAKUSHO CO.,LTD.**

# 超硬エンドミル

SOLID CARBIDE END MILL

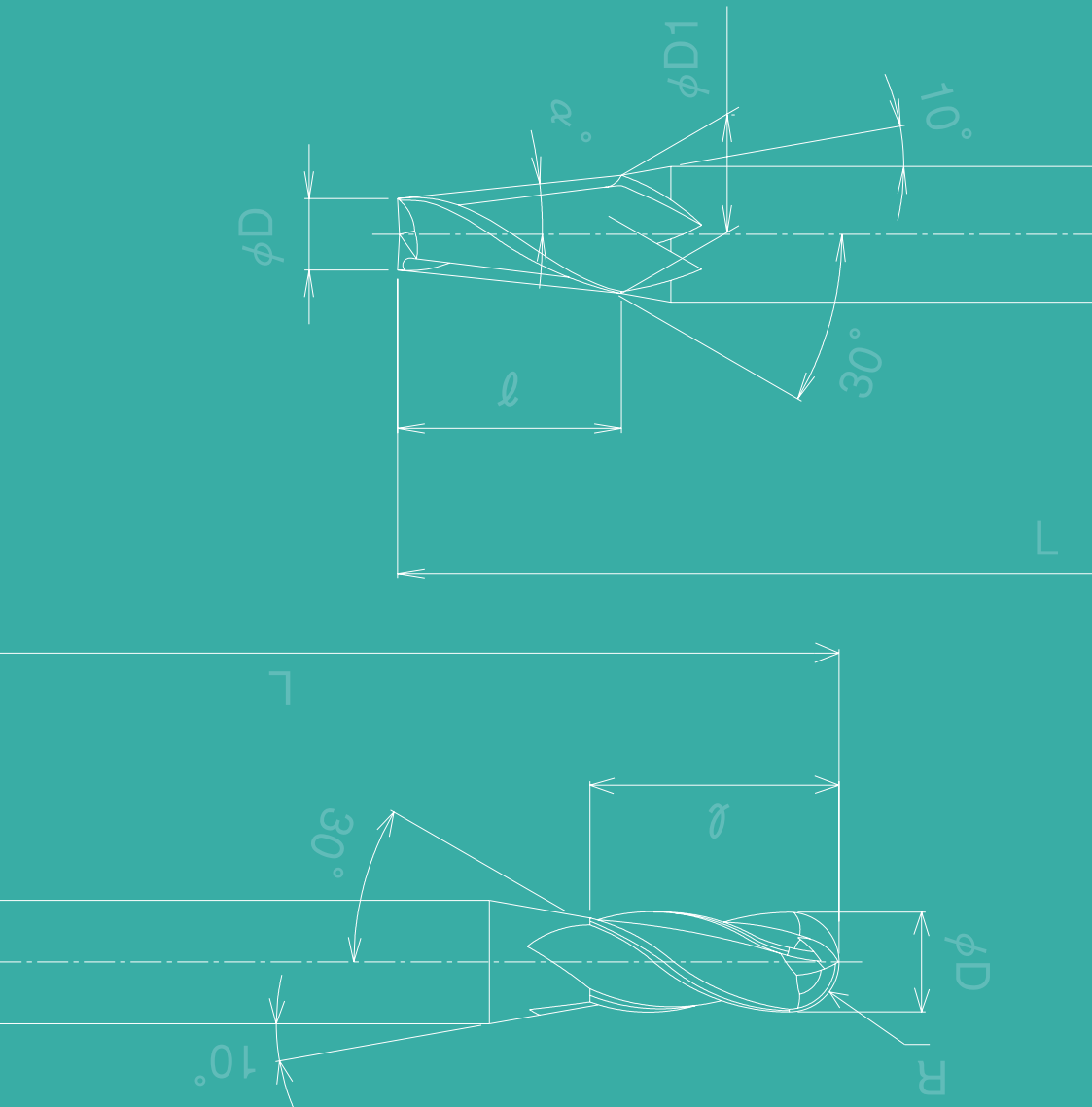

# 2枚刃微小径スクエアエンドミル

2-Flute Miniature Square End Mill

## AMES-2

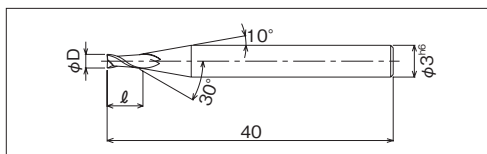

■ 精密金型、精密部品などの精度の厳しい加工に最適です。

Most suitable for precision molds and parts that requires stringent accuracy and tolerance.

刃径公差：+0~-0.01

$\phi D$  Tolerance

単位 Unit : mm

型番 CODE NUMBER	径 $\phi D$	刃長 $l$	全長 $L$	シャンク $d$	定価 ¥
AMES-20005	0.05	0.1	40	3	24,670
AMES-20006	0.06	0.1	40	3	23,170
AMES-20007	0.07	0.15	40	3	21,670
AMES-20008	0.08	0.15	40	3	20,000
AMES-20009	0.09	0.15	40	3	18,500
AMES-20010	0.1	0.2	40	3	16,340
AMES-20015	0.15	0.3	40	3	14,000
AMES-20020	0.2	0.4	40	3	11,670
AMES-20025	0.25	0.5	40	3	10,500
AMES-20030	0.3	1	40	3	8,170
AMES-20035	0.35	1	40	3	8,990
AMES-20040	0.4	1	40	3	8,170
AMES-20045	0.45	1	40	3	8,990
AMES-20050	0.5	1	40	3	7,590
AMES-20055	0.55	1	40	3	8,350
AMES-20060	0.6	2	40	3	7,590
AMES-20065	0.65	2	40	3	8,350
AMES-20070	0.7	2	40	3	7,120
AMES-20075	0.75	2	40	3	7,840
AMES-20080	0.8	2.5	40	3	7,120
AMES-20085	0.85	2.5	40	3	7,840
AMES-20090	0.9	2.5	40	3	6,770
AMES-20095	0.95	2.5	40	3	7,450



# 2枚刃スクエアエンドミル

## 2-Flute Square End Mill

# AES-2

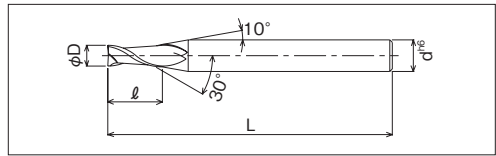

■ 一般鋼材から非鉄、樹脂まで幅広い適用が可能です。

Wide application available in work materials, from general steel to non-ferrous and resin.

刃径公差：+0~-0.02

φD Tolerance



単位 Unit : mm

型番 CODE NUMBER	径 φD	刃長 ℓ	全長 L	シャンク d	定価 ¥
AES-20100	1	3	40	4	5,850
AES-20105	1.05	3	40	4	7,100
AES-20110	1.1	3	40	4	6,450
AES-20115	1.15	3	40	4	7,100
AES-20120	1.2	3	40	4	6,450
AES-20125	1.25	3	40	4	7,100
AES-20130	1.3	3	40	4	6,450
AES-20135	1.35	3	40	4	7,100
AES-20140	1.4	3	40	4	6,450
AES-20145	1.45	3	40	4	7,100
AES-20150	1.5	5	40	4	5,850
AES-20155	1.55	5	40	4	7,100
AES-20160	1.6	5	40	4	6,450
AES-20165	1.65	5	40	4	7,100
AES-20170	1.7	5	40	4	6,450
AES-20175	1.75	5	40	4	7,100
AES-20180	1.8	5	40	4	6,450
AES-20185	1.85	5	40	4	7,100
AES-20190	1.9	5	40	4	6,450
AES-20195	1.95	5	40	4	7,100
AES-20200	2	6	40	4	5,850
AES-20205	2.05	6	40	4	7,100
AES-20210	2.1	6	40	4	6,450
AES-20215	2.15	6	40	4	7,100
AES-20220	2.2	6	40	4	6,450
AES-20225	2.25	6	40	4	7,100
AES-20230	2.3	6	40	4	6,450
AES-20235	2.35	6	40	4	7,100
AES-20240	2.4	6	40	4	6,450

型番 CODE NUMBER	径 φD	刃長 ℓ	全長 L	シャンク d	定価 ¥
AES-20245	2.45	6	40	4	7,100
AES-20250	2.5	8	40	4	5,850
AES-20255	2.55	8	40	4	7,100
AES-20260	2.6	8	40	4	6,450
AES-20265	2.65	8	40	4	7,100
AES-20270	2.7	8	40	4	6,450
AES-20275	2.75	8	40	4	7,100
AES-20280	2.8	8	40	4	6,450
AES-20285	2.85	8	40	4	7,100
AES-20290	2.9	8	40	4	6,450
AES-20295	2.95	8	40	4	7,100
AES-20300	3	8	45	4	6,400
AES-20305	3.05	8	45	4	7,770
AES-20310	3.1	8	45	4	7,050
AES-20315	3.15	8	45	4	7,770
AES-20320	3.2	8	45	4	7,050
AES-20325	3.25	8	45	4	7,770
AES-20330	3.3	8	45	4	7,050
AES-20335	3.35	8	45	4	7,770
AES-20340	3.4	8	45	4	7,050
AES-20345	3.45	8	45	4	7,770
AES-20350	3.5	10	45	4	6,400
AES-20355	3.55	10	45	4	7,770
AES-20360	3.6	10	45	4	7,050
AES-20365	3.65	10	45	4	7,770
AES-20370	3.7	10	45	4	7,050
AES-20375	3.75	10	45	4	7,770
AES-20380	3.8	10	45	4	7,050
AES-20385	3.85	10	45	4	7,770







# ロング刃 スクエアエンドミル

Long 2-Flute Square End Mill

## AEL

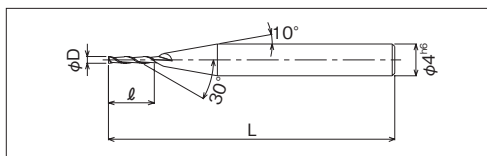

■ 最適刃長の選択が可能な豊富な刃長バリエーション。

Wide variation of flute length allows to select a suitable one.

■ 樹脂モデリング加工、非鉄部品加工に最適です。

Best for modeling work of resin and non-ferrous material parts.

刃径公差: +0~-0.03

φD Tolerance



単位 Unit : mm

型番 CODE NUMBER	径 φD	刃長 ℓ	全長 L	シャンク d	定価 ¥
AEL-20100-5	1	5	40	4	7,670
AEL-20100-6	1	6	40	4	8,000
AEL-20100-7.5	1	7.5	40	4	8,000
AEL-20100-10	1	10	40	4	8,670
AEL-20100-12	1	12	45	4	10,840
AEL-20110-7.5	1.1	7.5	40	4	8,000
AEL-20110-10	1.1	10	40	4	8,340
AEL-20110-12	1.1	12	45	4	9,170
AEL-20110-15	1.1	15	50	4	10,840
AEL-20120-7.5	1.2	7.5	40	4	8,000
AEL-20120-10	1.2	10	45	4	8,340
AEL-20120-12	1.2	12	45	4	9,170
AEL-20120-15	1.2	15	50	4	10,840
AEL-20130-8	1.3	8	40	4	8,170
AEL-20130-10	1.3	10	45	4	8,340
AEL-20130-12	1.3	12	45	4	9,170
AEL-20130-15	1.3	15	50	4	10,840
AEL-20140-8.5	1.4	8.5	40	4	8,340
AEL-20140-10	1.4	10	45	4	9,170
AEL-20140-12	1.4	12	45	4	9,670
AEL-20140-15	1.4	15	50	4	10,840
AEL-20150-10	1.5	10	40	4	8,670
AEL-20150-15	1.5	15	45	4	10,000
AEL-20150-18	1.5	18	55	4	11,340
AEL-20150-20	1.5	20	55	4	11,670
AEL-20160-10	1.6	10	40	4	8,670
AEL-20160-15	1.6	15	45	4	9,170

型番 CODE NUMBER	径 φD	刃長 ℓ	全長 L	シャンク d	定価 ¥
AEL-20160-20	1.6	20	55	4	10,840
AEL-20170-10	1.7	10	40	4	8,670
AEL-20170-15	1.7	15	45	4	9,170
AEL-20170-20	1.7	20	55	4	10,840
AEL-20180-10	1.8	10	40	4	8,670
AEL-20180-15	1.8	15	45	4	9,500
AEL-20180-20	1.8	20	55	4	10,840
AEL-20190-10	1.9	10	40	4	8,670
AEL-20190-15	1.9	15	45	4	9,500
AEL-20190-20	1.9	20	55	4	10,840
AEL-20200-10	2	10	40	4	7,500
AEL-20200-12	2	12	40	4	7,500
AEL-20200-15	2	15	45	4	8,500
AEL-20200-20	2	20	55	4	9,670
AEL-20200-25	2	25	60	4	13,170
AEL-20210-15	2.1	15	45	4	8,500
AEL-20210-20	2.1	20	55	4	10,000
AEL-20220-15	2.2	15	45	4	8,500
AEL-20220-20	2.2	20	55	4	10,000
AEL-20230-15	2.3	15	45	4	8,500
AEL-20230-20	2.3	20	55	4	10,840
AEL-20240-15	2.4	15	45	4	8,500
AEL-20240-20	2.4	20	55	4	10,840
AEL-20250-15	2.5	15	50	4	8,000
AEL-20250-20	2.5	20	55	4	10,000
AEL-20250-25	2.5	25	60	4	10,840
AEL-20260-15	2.6	15	50	4	8,500



# 4枚刃 スクエアエンドミル

4-Flute Square End Mill

## AES-4

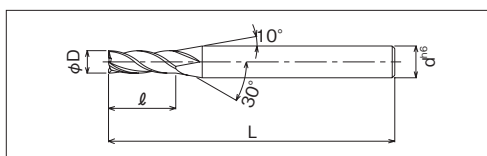

■ 一般鋼材から非鉄、樹脂まで幅広い適用が可能です。

Wide application available in work materials, from general steel to non-ferrous and resin.

■ 高剛性4枚刃で溝加工から側面加工まで対応。

Capable for both grooving and precision side milling.

刃径公差: +0~-0.02

φD Tolerance



単位 Unit : mm

型番 CODE NUMBER	径 φD	刃長 ℓ	全長 L	シャンク d	定価 ¥
AES-40100	1	3	40	4	7,590
AES-40110	1.1	3	40	4	8,340
AES-40120	1.2	3	40	4	8,340
AES-40130	1.3	3	40	4	8,340
AES-40140	1.4	3	40	4	8,340
AES-40150	1.5	5	40	4	7,590
AES-40160	1.6	5	40	4	8,340
AES-40170	1.7	5	40	4	8,340
AES-40180	1.8	5	40	4	8,340
AES-40190	1.9	5	40	4	8,340
AES-40200	2	6	40	4	6,770
AES-40210	2.1	6	40	4	7,450
AES-40220	2.2	6	40	4	7,450
AES-40230	2.3	6	40	4	7,450
AES-40240	2.4	6	40	4	7,450
AES-40250	2.5	8	40	4	6,720
AES-40260	2.6	8	40	4	8,000
AES-40270	2.7	8	40	4	8,000
AES-40280	2.8	8	40	4	8,000
AES-40290	2.9	8	40	4	8,000
AES-40300	3	8	45	4	7,270
AES-40310	3.1	8	45	4	8,000
AES-40320	3.2	8	45	4	8,000
AES-40330	3.3	8	45	4	8,000
AES-40340	3.4	8	45	4	8,000
AES-40350	3.5	10	45	4	7,270
AES-40360	3.6	10	45	4	8,350

型番 CODE NUMBER	径 φD	刃長 ℓ	全長 L	シャンク d	定価 ¥
AES-40370	3.7	10	45	4	8,350
AES-40380	3.8	10	45	4	8,350
AES-40390	3.9	10	45	4	8,350
AES-40400	4	12	45	6	7,590
AES-40410	4.1	12	45	6	8,350
AES-40420	4.2	12	45	6	8,350
AES-40430	4.3	12	45	6	8,350
AES-40440	4.4	12	45	6	8,350
AES-40450	4.5	12	45	6	7,590
AES-40460	4.6	12	45	6	9,300
AES-40470	4.7	12	45	6	9,300
AES-40480	4.8	12	45	6	9,300
AES-40490	4.9	12	45	6	9,300
AES-40500	5	15	60	6	8,450
AES-40550	5.5	15	60	6	8,450
AES-40600	6	15	60	6	9,220
AES-40650	6.5	15	60	6	9,220
AES-40700	7	20	60	8	10,950
AES-40750	7.5	20	60	8	10,950
AES-40800	8	20	60	8	12,040
AES-40850	8.5	20	60	8	12,040
AES-40900	9	20	70	10	14,950
AES-40950	9.5	20	70	10	14,950
AES-41000	10	25	70	10	16,840
AES-41100	11	25	75	12	17,990
AES-41200	12	25	75	12	19,940



# 2枚刃 ボールエンドミル

2-Flute Ball End Mill

## ABES-2

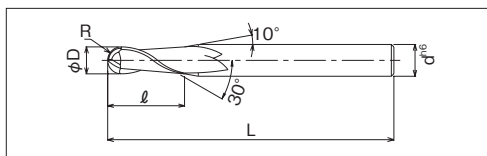

■ 一般鋼材から非鉄、樹脂まで幅広い適用が可能です。

Wide application available in work materials, from general steel to non-ferrous and resin.

■ ノンコート製のシャープな切れ味が高精度、高品位な仕上げ面を実現します。

Uncoated sharp cutting edge realize high precision and fine surface finish.

刃径公差: +0~-0.02 R公差: ±0.01

φD Tolerance

R Tolerance



単位 Unit : mm

型番 CODE NUMBER	R	径 φD	刃長 ℓ	全長 L	シャンク d	定価 ¥
ABES-20100	0.5	1	3	40	4	7,590
ABES-20110	0.55	1.1	3	40	4	8,350
ABES-20120	0.6	1.2	3	40	4	8,350
ABES-20130	0.65	1.3	3	40	4	8,350
ABES-20140	0.7	1.4	3	40	4	8,350
ABES-20150	0.75	1.5	5	40	4	7,590
ABES-20160	0.8	1.6	5	40	4	8,350
ABES-20170	0.85	1.7	5	40	4	8,350
ABES-20180	0.9	1.8	5	40	4	8,350
ABES-20190	0.95	1.9	5	40	4	8,350
ABES-20200	1	2	6	40	4	7,590
ABES-20210	1.05	2.1	6	40	4	8,350
ABES-20220	1.1	2.2	6	40	4	8,350
ABES-20230	1.15	2.3	6	40	4	8,350
ABES-20240	1.2	2.4	6	40	4	8,350
ABES-20250	1.25	2.5	8	40	4	7,590
ABES-20260	1.3	2.6	8	40	4	9,250
ABES-20270	1.35	2.7	8	40	4	9,250
ABES-20280	1.4	2.8	8	40	4	9,250
ABES-20290	1.45	2.9	8	40	4	9,250
ABES-20300	1.5	3	8	45	4	8,400
ABES-20310	1.55	3.1	8	45	4	9,250
ABES-20320	1.6	3.2	8	45	4	9,250
ABES-20330	1.65	3.3	8	45	4	9,250
ABES-20340	1.7	3.4	8	45	4	9,250
ABES-20350	1.75	3.5	10	45	4	8,400
ABES-20360	1.8	3.6	10	45	4	9,770

型番 CODE NUMBER	R	径 φD	刃長 ℓ	全長 L	シャンク d	定価 ¥
ABES-20370	1.85	3.7	10	45	4	9,770
ABES-20380	1.9	3.8	10	45	4	9,770
ABES-20390	1.95	3.9	10	45	4	9,770
ABES-20400	2	4	12	45	6	8,870
ABES-20410	2.05	4.1	12	45	6	9,770
ABES-20420	2.1	4.2	12	45	6	9,770
ABES-20430	2.15	4.3	12	45	6	9,770
ABES-20440	2.2	4.4	12	45	6	9,770
ABES-20450	2.25	4.5	12	45	6	8,870
ABES-20460	2.3	4.6	12	45	6	10,790
ABES-20470	2.35	4.7	12	45	6	10,790
ABES-20480	2.4	4.8	12	45	6	10,790
ABES-20490	2.45	4.9	12	45	6	10,790
ABES-20500	2.5	5	15	60	6	9,800
ABES-20510	2.55	5.1	15	60	6	10,790
ABES-20520	2.6	5.2	15	60	6	10,790
ABES-20530	2.65	5.3	15	60	6	10,790
ABES-20540	2.7	5.4	15	60	6	10,790
ABES-20550	2.75	5.5	15	60	6	9,800
ABES-20560	2.8	5.6	15	60	6	11,820
ABES-20570	2.85	5.7	15	60	6	11,820
ABES-20580	2.9	5.8	15	60	6	11,820
ABES-20590	2.95	5.9	15	60	6	11,820
ABES-20600	3	6	15	60	6	10,740
ABES-20610	3.05	6.1	15	60	6	13,740
ABES-20620	3.1	6.2	15	60	6	13,740
ABES-20630	3.15	6.3	15	60	6	13,740

単位 Unit : mm

型番 CODE NUMBER	R	径 φD	刃長 ℓ	全長 L	シャンク d	定価 ¥
ABES-20635	3.175	6.35	15	60	6	13,740
ABES-20640	3.2	6.4	15	60	6	13,740
ABES-20650	3.25	6.5	15	60	6	13,740
ABES-20660	3.3	6.6	15	60	6	13,740
ABES-20670	3.35	6.7	15	60	6	13,740
ABES-20680	3.4	6.8	15	60	6	13,740
ABES-20690	3.45	6.9	15	60	6	13,740
ABES-20700	3.5	7	20	60	8	12,490
ABES-20710	3.55	7.1	20	60	8	15,400
ABES-20720	3.6	7.2	20	60	8	15,400
ABES-20730	3.65	7.3	20	60	8	15,400
ABES-20740	3.7	7.4	20	60	8	15,400
ABES-20750	3.75	7.5	20	60	8	15,400
ABES-20760	3.8	7.6	20	60	8	15,400
ABES-20770	3.85	7.7	20	60	8	15,400
ABES-20780	3.9	7.8	20	60	8	15,400
ABES-20790	3.95	7.9	20	60	8	15,400
ABES-20800	4	8	20	60	8	14,000
ABES-20810	4.05	8.1	20	60	8	18,620
ABES-20820	4.1	8.2	20	60	8	18,620
ABES-20830	4.15	8.3	20	60	8	18,620
ABES-20840	4.2	8.4	20	60	8	18,620
ABES-20850	4.25	8.5	20	60	8	18,620
ABES-20860	4.3	8.6	20	60	8	18,620
ABES-20870	4.35	8.7	20	60	8	18,620
ABES-20880	4.4	8.8	20	60	8	18,620
ABES-20890	4.45	8.9	20	60	8	18,620
ABES-20900	4.5	9	20	70	10	16,920
ABES-20910	4.55	9.1	20	70	10	21,570
ABES-20920	4.6	9.2	20	70	10	21,570
ABES-20930	4.65	9.3	20	70	10	21,570
ABES-20940	4.7	9.4	20	70	10	21,570
ABES-20950	4.75	9.5	20	70	10	21,570
ABES-20960	4.8	9.6	20	70	10	21,570
ABES-20970	4.85	9.7	20	70	10	21,570
ABES-20980	4.9	9.8	20	70	10	21,570
ABES-20990	4.95	9.9	20	70	10	21,570
ABES-21000	5	10	25	70	10	19,600
ABES-21010	5.05	10.1	25	70	10	23,750
ABES-21020	5.1	10.2	25	70	10	23,750
ABES-21030	5.15	10.3	25	70	10	23,750
ABES-21040	5.2	10.4	25	70	10	23,750
ABES-21050	5.25	10.5	25	70	10	23,750
ABES-21060	5.3	10.6	25	70	10	23,750

型番 CODE NUMBER	R	径 φD	刃長 ℓ	全長 L	シャンク d	定価 ¥
ABES-21070	5.35	10.7	25	70	10	23,750
ABES-21080	5.4	10.8	25	70	10	23,750
ABES-21090	5.45	10.9	25	70	10	23,750
ABES-21100	5.5	11	25	75	12	21,590
ABES-21110	5.55	11.1	25	75	12	25,670
ABES-21120	5.6	11.2	25	75	12	25,670
ABES-21130	5.65	11.3	25	75	12	25,670
ABES-21140	5.7	11.4	25	75	12	25,670
ABES-21150	5.75	11.5	25	75	12	25,670
ABES-21160	5.8	11.6	25	75	12	25,670
ABES-21170	5.85	11.7	25	75	12	25,670
ABES-21180	5.9	11.8	25	75	12	25,670
ABES-21190	5.95	11.9	25	75	12	25,670
ABES-21200	6	12	25	75	12	23,340
ABES-21210	6.05	12.1	25	75	12	28,000
ABES-21220	6.1	12.2	25	75	12	28,000
ABES-21230	6.15	12.3	25	75	12	30,000
ABES-21240	6.2	12.4	25	75	12	28,000
ABES-21250	6.25	12.5	25	75	12	30,000
ABES-21260	6.3	12.6	25	75	12	28,000
ABES-21270	6.35	12.7	25	75	12	34,400
ABES-21280	6.4	12.8	25	75	12	31,270
ABES-21290	6.45	12.9	25	75	12	34,400
ABES-21300	6.5	13	30	80	12	31,270
ABES-21350	6.75	13.5	30	80	12	43,000
ABES-21360	6.8	13.6	30	80	12	43,000
ABES-21370	6.85	13.7	30	80	12	43,000
ABES-21380	6.9	13.8	30	80	12	43,000
ABES-21390	6.95	13.9	30	80	12	43,000
ABES-21400	7	14	30	90	16	39,090
ABES-21410	7.05	14.1	30	90	16	44,670
ABES-21420	7.1	14.2	30	90	16	44,670
ABES-21430	7.15	14.3	30	90	16	44,670
ABES-21440	7.2	14.4	30	90	16	44,670
ABES-21450	7.25	14.5	30	90	16	44,670
ABES-21460	7.3	14.6	30	90	16	44,670
ABES-21470	7.35	14.7	30	90	16	44,670
ABES-21480	7.4	14.8	30	90	16	44,670
ABES-21490	7.45	14.9	30	90	16	44,670
ABES-21500	7.5	15	30	90	16	40,600
ABES-21510	7.55	15.1	30	90	16	46,200
ABES-21520	7.6	15.2	30	90	16	46,200
ABES-21530	7.65	15.3	30	90	16	46,210
ABES-21540	7.7	15.4	30	90	16	46,210

Next Page ▶







# テーパエンドミル

## 2-Flute Taper End Mill

# ATES-2

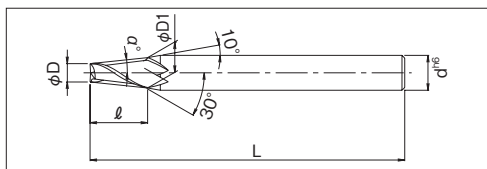

■ 最大テーパ角15° まで標準化した小径テーパエンドミルです。

Micro Taper End Mill with largest taper angle to 15°

外径公差：φD Tolerance

+0 ~ -0.015 (φ0.1 ~ 0.5)

+0 ~ -0.02 (φ0.6 ~ 0.9)

+0 ~ -0.025 (φ1 ~ 1.9)

+0 ~ -0.03 (φ2 ~ 3)



単位 Unit : mm

型番 CODE NUMBER	径 φD	刃長 ℓ	片角 α°	大端径 φD1	全長 L	シャンク φd	定価 ¥
ATES-20101	0.1	0.5	30°	0.11	35	3	25,800
ATES-20102	0.1	0.5	1°	0.12	35	3	25,800
ATES-20103	0.1	0.5	1°30'	0.13	35	3	25,800
ATES-20104	0.1	0.5	2°	0.13	35	3	25,800
ATES-20105	0.1	0.5	2°30'	0.14	35	3	25,800
ATES-20106	0.1	0.5	3°	0.15	35	3	25,800
ATES-20107	0.1	0.5	4°	0.17	35	3	25,800
ATES-20108	0.1	0.5	5°	0.19	35	3	27,700
ATES-20109	0.1	0.5	7°	0.22	35	3	27,700
ATES-20110	0.1	0.5	10°	0.28	35	3	29,800
ATES-20111	0.1	0.5	15°	0.37	35	3	33,300
ATES-20201	0.2	1	30°	0.22	35	3	25,700
ATES-20202	0.2	1	1°	0.23	35	3	25,700
ATES-20203	0.2	1	1°30'	0.25	35	3	25,700
ATES-20204	0.2	1	2°	0.27	35	3	25,700
ATES-20205	0.2	1	2°30'	0.29	35	3	25,700
ATES-20206	0.2	1	3°	0.3	35	3	25,700
ATES-20207	0.2	1	4°	0.34	35	3	25,700
ATES-20208	0.2	1	5°	0.37	35	3	27,300
ATES-20209	0.2	1	7°	0.45	35	3	27,300
ATES-20210	0.2	1	10°	0.55	35	3	29,300
ATES-20211	0.2	1	15°	0.74	35	3	32,800
ATES-20301	0.3	1.5	30°	0.33	35	3	12,300
ATES-20302	0.3	1.5	1°	0.35	35	3	12,300
ATES-20303	0.3	1.5	1°30'	0.38	35	3	12,300
ATES-20304	0.3	1.5	2°	0.4	35	3	12,300
ATES-20305	0.3	1.5	2°30'	0.43	35	3	12,300

単位 Unit : mm

型番 CODE NUMBER	径 φD	刃長 ℓ	片角 α°	大端径 φD1	全長 L	シャンク φd	定価 ¥
ATES-20306	0.3	1.5	3°	0.46	35	3	12,300
ATES-20307	0.3	1.5	4°	0.51	35	3	12,300
ATES-20308	0.3	1.5	5°	0.56	35	3	18,800
ATES-20309	0.3	1.5	7°	0.67	35	3	18,800
ATES-20310	0.3	1.5	10°	0.83	35	3	22,300
ATES-20311	0.3	1.5	15°	1.1	35	3	26,700
ATES-20401	0.4	2	30'	0.43	35	3	11,200
ATES-20402	0.4	2	1°	0.47	35	3	11,200
ATES-20403	0.4	2	1°30'	0.5	35	3	11,200
ATES-20404	0.4	2	2°	0.54	35	3	11,200
ATES-20405	0.4	2	2°30'	0.57	35	3	11,200
ATES-20406	0.4	2	3°	0.61	35	3	11,200
ATES-20407	0.4	2	4°	0.68	35	3	11,200
ATES-20408	0.4	2	5°	0.75	35	3	17,800
ATES-20409	0.4	2	7°	0.89	35	3	17,800
ATES-20410	0.4	2	10°	1.11	35	3	21,700
ATES-20411	0.4	2	15°	1.47	35	3	25,800
ATES-20501	0.5	2	30'	0.53	35	3	11,300
ATES-20502	0.5	2	1°	0.57	35	3	11,300
ATES-20503	0.5	2	1°30'	0.6	35	3	11,300
ATES-20504	0.5	2	2°	0.64	35	3	11,300
ATES-20505	0.5	2	2°30'	0.67	35	3	11,300
ATES-20506	0.5	2	3°	0.71	35	3	11,300
ATES-20507	0.5	2	4°	0.78	35	3	11,300
ATES-20508	0.5	2	5°	0.85	35	3	17,500
ATES-20509	0.5	2	7°	0.99	35	3	17,500
ATES-20510	0.5	2	10°	1.21	35	3	21,700
ATES-20511	0.5	2	15°	1.57	35	3	25,800
ATES-20601	0.6	3	30'	0.65	35	3	11,500
ATES-20602	0.6	3	1°	0.7	35	3	11,500
ATES-20603	0.6	3	1°30'	0.76	35	3	11,500
ATES-20604	0.6	3	2°	0.81	35	3	11,500
ATES-20605	0.6	3	2°30'	0.86	35	3	11,500
ATES-20606	0.6	3	3°	0.91	35	3	11,500
ATES-20607	0.6	3	4°	1.02	35	3	11,500
ATES-20608	0.6	3	5°	1.12	35	3	21,300
ATES-20609	0.6	3	7°	1.34	35	3	21,300
ATES-20610	0.6	3	10°	1.66	35	3	21,700
ATES-20611	0.6	3	15°	2.21	35	3	25,800
ATES-20701	0.7	3	30'	0.75	35	3	11,300
ATES-20702	0.7	3	1°	0.8	35	3	11,300
ATES-20703	0.7	3	1°30'	0.86	35	3	11,300
ATES-20704	0.7	3	2°	0.91	35	3	11,300
ATES-20705	0.7	3	2°30'	0.96	35	3	11,300

Next Page ▶

型番 CODE NUMBER	径 φD	刃長 ℓ	片角 α°	大端径 φD1	全長 L	シャンク φd	定価 ¥
ATES-20706	0.7	3	3°	1.01	35	3	11,300
ATES-20707	0.7	3	4°	1.12	35	3	11,300
ATES-20708	0.7	3	5°	1.22	35	3	21,300
ATES-20709	0.7	3	7°	1.44	35	3	21,300
ATES-20710	0.7	3	10°	1.76	35	3	21,700
ATES-20711	0.7	3	15°	2.31	35	3	25,800
ATES-20801	0.8	4	30'	0.87	35	3	10,300
ATES-20802	0.8	4	1°	0.94	35	3	10,300
ATES-20803	0.8	4	1°30'	1.01	35	3	10,300
ATES-20804	0.8	4	2°	1.08	35	3	10,300
ATES-20805	0.8	4	2°30'	1.15	35	3	10,300
ATES-20806	0.8	4	3°	1.22	35	3	10,300
ATES-20807	0.8	4	4°	1.36	35	3	10,300
ATES-20808	0.8	4	5°	1.5	35	3	16,200
ATES-20809	0.8	4	7°	1.78	35	3	16,200
ATES-20810	0.8	4	10°	2.21	35	3	19,700
ATES-20811	0.8	4	15°	2.94	35	3	23,500
ATES-20901	0.9	4	30'	0.97	35	3	10,300
ATES-20902	0.9	4	1°	1.04	35	3	10,300
ATES-20903	0.9	4	1°30'	1.11	35	3	10,300
ATES-20904	0.9	4	2°	1.18	35	3	10,300
ATES-20905	0.9	4	2°30'	1.25	35	3	10,300
ATES-20906	0.9	4	3°	1.32	35	3	10,300
ATES-20907	0.9	4	4°	1.46	35	3	10,300
ATES-20908	0.9	4	5°	1.6	35	3	16,200
ATES-20909	0.9	4	7°	1.88	35	3	16,200
ATES-20910	0.9	4	10°	2.31	35	3	19,700
ATES-20911	0.9	4	15°	3.04	35	4	23,500
ATES-21001	1	4	30'	1.07	45	4	8,700
ATES-21002	1	4	1°	1.14	45	4	8,700
ATES-21003	1	4	1°30'	1.21	45	4	8,700
ATES-21004	1	4	2°	1.28	45	4	8,700
ATES-21005	1	4	2°30'	1.35	45	4	8,700
ATES-21006	1	4	3°	1.42	45	4	8,700
ATES-21007	1	4	4°	1.56	45	4	8,700
ATES-21008	1	4	5°	1.7	45	4	13,300
ATES-21009	1	4	7°	1.98	45	4	13,300
ATES-21010	1	4	10°	2.41	45	4	14,800
ATES-21011	1	4	15°	3.14	45	4	17,800
ATES-21101	1.1	5	30'	1.19	45	4	8,700
ATES-21102	1.1	5	1°	1.27	45	4	8,700
ATES-21103	1.1	5	1°30'	1.36	45	4	8,700
ATES-21104	1.1	5	2°	1.45	45	4	8,700
ATES-21105	1.1	5	2°30'	1.54	45	4	8,700

単位 Unit : mm

型番 CODE NUMBER	径 φD	刃長 ℓ	片角 α°	大端径 φD1	全長 L	シャンク φd	定価 ¥
ATES-21106	1.1	5	3°	1.62	45	4	8,700
ATES-21107	1.1	5	4°	1.8	45	4	8,700
ATES-21108	1.1	5	5°	1.97	45	4	13,300
ATES-21109	1.1	5	7°	2.33	45	4	13,300
ATES-21110	1.1	5	10°	2.86	45	4	14,800
ATES-21111	1.1	5	15°	3.78	45	4	17,800
ATES-21201	1.2	5	30'	1.29	45	4	8,700
ATES-21202	1.2	5	1°	1.37	45	4	8,700
ATES-21203	1.2	5	1°30'	1.46	45	4	8,700
ATES-21204	1.2	5	2°	1.55	45	4	8,700
ATES-21205	1.2	5	2°30'	1.64	45	4	8,700
ATES-21206	1.2	5	3°	1.72	45	4	8,700
ATES-21207	1.2	5	4°	1.9	45	4	8,700
ATES-21208	1.2	5	5°	2.07	45	4	13,300
ATES-21209	1.2	5	7°	2.43	45	4	13,300
ATES-21210	1.2	5	10°	2.96	45	4	14,800
ATES-21211	1.2	5	15°	3.88	45	4	17,800
ATES-21301	1.3	5	30'	1.39	45	4	8,700
ATES-21302	1.3	5	1°	1.47	45	4	8,700
ATES-21303	1.3	5	1°30'	1.56	45	4	8,700
ATES-21304	1.3	5	2°	1.65	45	4	8,700
ATES-21305	1.3	5	2°30'	1.74	45	4	8,700
ATES-21306	1.3	5	3°	1.82	45	4	8,700
ATES-21307	1.3	5	4°	2	45	4	8,700
ATES-21308	1.3	5	5°	2.17	45	4	13,300
ATES-21309	1.3	5	7°	2.53	45	4	13,300
ATES-21310	1.3	5	10°	3.06	45	4	14,800
ATES-21311	1.3	5	15°	3.98	45	4	17,800
ATES-21401	1.4	5	30'	1.49	45	4	8,700
ATES-21402	1.4	5	1°	1.57	45	4	8,700
ATES-21403	1.4	5	1°30'	1.66	45	4	8,700
ATES-21404	1.4	5	2°	1.75	45	4	8,700
ATES-21405	1.4	5	2°30'	1.84	45	4	8,700
ATES-21406	1.4	5	3°	1.92	45	4	8,700
ATES-21407	1.4	5	4°	2.1	45	4	8,700
ATES-21408	1.4	5	5°	2.27	45	4	13,300
ATES-21409	1.4	5	7°	2.63	45	4	13,300
ATES-21410	1.4	5	10°	3.16	45	4	14,800
ATES-21411	1.4	5	15°	4.08	45	6	17,800
ATES-21501	1.5	6	30'	1.6	45	4	9,000
ATES-21502	1.5	6	1°	1.71	45	4	9,000
ATES-21503	1.5	6	1°30'	1.81	45	4	9,000
ATES-21504	1.5	6	2°	1.92	45	4	9,000
ATES-21505	1.5	6	2°30'	2.02	45	4	9,000

Next Page ▶

切削条件 Cutting Condition P.181

型番 CODE NUMBER	径 φD	刃長 ℓ	片角 α°	大端径 φD1	全長 L	シャンク φd	定価 ¥
ATES-21506	1.5	6	3°	2.13	45	4	9,000
ATES-21507	1.5	6	4°	2.34	45	4	9,000
ATES-21508	1.5	6	5°	2.55	45	4	13,300
ATES-21509	1.5	6	7°	2.97	45	4	13,300
ATES-21510	1.5	6	10°	3.62	45	4	14,800
ATES-21511	1.5	6	15°	4.72	45	6	17,800
ATES-21601	1.6	7	30'	1.72	45	4	9,000
ATES-21602	1.6	7	1°	1.84	45	4	9,000
ATES-21603	1.6	7	1°30'	1.97	45	4	9,000
ATES-21604	1.6	7	2°	2.09	45	4	9,000
ATES-21605	1.6	7	2°30'	2.21	45	4	9,000
ATES-21606	1.6	7	3°	2.33	45	4	9,000
ATES-21607	1.6	7	4°	2.58	45	4	9,000
ATES-21608	1.6	7	5°	2.82	45	4	13,300
ATES-21609	1.6	7	7°	3.32	45	4	13,300
ATES-21610	1.6	7	10°	4.07	45	6	14,800
ATES-21611	1.6	7	15°	5.35	45	6	17,800
ATES-21701	1.7	7	30'	1.82	45	4	9,000
ATES-21702	1.7	7	1°	1.94	45	4	9,000
ATES-21703	1.7	7	1°30'	2.07	45	4	9,000
ATES-21704	1.7	7	2°	2.19	45	4	9,000
ATES-21705	1.7	7	2°30'	2.31	45	4	9,000
ATES-21706	1.7	7	3°	2.43	45	4	9,000
ATES-21707	1.7	7	4°	2.68	45	4	9,000
ATES-21708	1.7	7	5°	2.92	45	4	13,300
ATES-21709	1.7	7	7°	3.42	45	4	13,300
ATES-21710	1.7	7	10°	4.17	45	6	14,800
ATES-21711	1.7	7	15°	5.45	45	6	17,800
ATES-21801	1.8	7	30'	1.92	45	4	9,000
ATES-21802	1.8	7	1°	2.04	45	4	9,000
ATES-21803	1.8	7	1°30'	2.17	45	4	9,000
ATES-21804	1.8	7	2°	2.29	45	4	9,000
ATES-21805	1.8	7	2°30'	2.41	45	4	9,000
ATES-21806	1.8	7	3°	2.53	45	4	9,000
ATES-21807	1.8	7	4°	2.78	45	4	9,000
ATES-21808	1.8	7	5°	3.02	45	4	13,300
ATES-21809	1.8	7	7°	3.52	45	4	13,300
ATES-21810	1.8	7	10°	4.27	45	6	14,800
ATES-21811	1.8	7	15°	5.55	45	6	17,800
ATES-21901	1.9	8	30'	2.04	45	4	9,000
ATES-21902	1.9	8	1°	2.18	45	4	9,000
ATES-21903	1.9	8	1°30'	2.32	45	4	9,000
ATES-21904	1.9	8	2°	2.46	45	4	9,000
ATES-21905	1.9	8	2°30'	2.6	45	4	9,000

単位 Unit : mm

型番 CODE NUMBER	径 φD	刃長 ℓ	片角 α°	大端径 φD1	全長 L	シャンク φd	定価 ¥
ATES-21906	1.9	8	3°	2.74	45	4	9,000
ATES-21907	1.9	8	4°	3.02	45	4	9,000
ATES-21908	1.9	8	5°	3.3	45	4	13,300
ATES-21909	1.9	8	7°	3.86	45	4	13,300
ATES-21910	1.9	8	10°	4.72	45	6	14,800
ATES-21911	1.9	8	15°	6.19	45	8	17,800
ATES-22001	2	8	30'	2.14	45	4	8,800
ATES-22002	2	8	1°	2.28	45	4	8,800
ATES-22003	2	8	1°30'	2.42	45	4	8,800
ATES-22004	2	8	2°	2.56	45	4	8,800
ATES-22005	2	8	2°30'	2.7	45	4	8,800
ATES-22006	2	8	3°	2.84	45	4	8,800
ATES-22007	2	8	4°	3.12	45	4	8,800
ATES-22008	2	8	5°	3.4	45	4	9,300
ATES-22009	2	8	7°	3.96	45	4	9,300
ATES-22010	2	8	10°	4.82	45	6	14,700
ATES-22011	2	8	15°	6.29	45	8	17,800
ATES-22101	2.1	8	30'	2.24	45	4	9,700
ATES-22102	2.1	8	1°	2.38	45	4	9,700
ATES-22103	2.1	8	1°30'	2.52	45	4	9,700
ATES-22104	2.1	8	2°	2.66	45	4	9,700
ATES-22105	2.1	8	2°30'	2.8	45	4	9,700
ATES-22106	2.1	8	3°	2.94	45	4	9,700
ATES-22107	2.1	8	4°	3.22	45	4	9,700
ATES-22108	2.1	8	5°	3.5	45	4	10,000
ATES-22109	2.1	8	7°	4.06	45	4	10,000
ATES-22110	2.1	8	10°	4.92	45	6	15,000
ATES-22111	2.1	8	15°	6.39	45	8	17,800
ATES-22201	2.2	9	30'	2.36	45	4	9,700
ATES-22202	2.2	9	1°	2.51	45	4	9,700
ATES-22203	2.2	9	1°30'	2.67	45	4	9,700
ATES-22204	2.2	9	2°	2.83	45	4	9,700
ATES-22205	2.2	9	2°30'	2.99	45	4	9,700
ATES-22206	2.2	9	3°	3.14	45	4	9,700
ATES-22207	2.2	9	4°	3.46	45	4	9,700
ATES-22208	2.2	9	5°	3.77	45	4	10,000
ATES-22209	2.2	9	7°	4.41	45	6	10,000
ATES-22210	2.2	9	10°	5.37	45	6	15,000
ATES-22211	2.2	9	15°	7.02	45	8	17,800
ATES-22301	2.3	9	30'	2.46	45	4	9,700
ATES-22302	2.3	9	1°	2.61	45	4	9,700
ATES-22303	2.3	9	1°30'	2.77	45	4	9,700
ATES-22304	2.3	9	2°	2.93	45	4	9,700
ATES-22305	2.3	9	2°30'	3.09	45	4	9,700

Next Page ▶

切削条件 Cutting Condition P.181

型番 CODE NUMBER	径 φD	刃長 ℓ	片角 α°	大端径 φD1	全長 L	シャンク φd	定価 ¥
ATES-22306	2.3	9	3°	3.24	45	4	9,700
ATES-22307	2.3	9	4°	3.56	45	4	9,700
ATES-22308	2.3	9	5°	3.87	45	4	10,000
ATES-22309	2.3	9	7°	4.51	45	6	10,000
ATES-22310	2.3	9	10°	5.47	45	6	15,000
ATES-22311	2.3	9	15°	7.12	45	8	17,800
ATES-22401	2.4	10	30'	2.57	45	4	10,000
ATES-22402	2.4	10	1°	2.75	45	4	10,000
ATES-22403	2.4	10	1°30'	2.92	45	4	10,000
ATES-22404	2.4	10	2°	3.1	45	4	10,000
ATES-22405	2.4	10	2°30'	3.27	45	4	10,000
ATES-22406	2.4	10	3°	3.45	45	4	10,000
ATES-22407	2.4	10	4°	3.8	45	4	10,000
ATES-22408	2.4	10	5°	4.15	45	6	11,700
ATES-22409	2.4	10	7°	4.86	45	6	11,700
ATES-22410	2.4	10	10°	5.93	45	6	16,300
ATES-22411	2.4	10	15°	7.76	45	8	18,800
ATES-22501	2.5	10	30'	2.67	45	4	9,000
ATES-22502	2.5	10	1°	2.85	45	4	9,000
ATES-22503	2.5	10	1°30'	3.02	45	4	9,000
ATES-22504	2.5	10	2°	3.2	45	4	9,000
ATES-22505	2.5	10	2°30'	3.37	45	4	9,000
ATES-22506	2.5	10	3°	3.55	45	4	9,000
ATES-22507	2.5	10	4°	3.9	45	4	9,000
ATES-22508	2.5	10	5°	4.25	45	6	10,000
ATES-22509	2.5	10	7°	4.96	45	6	10,000
ATES-22510	2.5	10	10°	6.03	45	6	16,300
ATES-22511	2.5	10	15°	7.86	45	8	18,800
ATES-22601	2.6	11	30'	2.79	50	6	12,000
ATES-22602	2.6	11	1°	2.98	50	6	12,000
ATES-22603	2.6	11	1°30'	3.18	50	6	12,000
ATES-22604	2.6	11	2°	3.37	50	6	12,000
ATES-22605	2.6	11	2°30'	3.56	50	6	12,000
ATES-22606	2.6	11	3°	3.75	50	6	12,000
ATES-22607	2.6	11	4°	4.14	50	6	12,000
ATES-22608	2.6	11	5°	4.52	50	6	13,000
ATES-22609	2.6	11	7°	5.3	50	6	13,000
ATES-22610	2.6	11	10°	6.48	50	8	19,300
ATES-22611	2.6	11	15°	8.49	50	10	24,200
ATES-22701	2.7	11	30'	2.89	50	6	12,000
ATES-22702	2.7	11	1°	3.08	50	6	12,000
ATES-22703	2.7	11	1°30'	3.28	50	6	12,000
ATES-22704	2.7	11	2°	3.47	50	6	12,000
ATES-22705	2.7	11	2°30'	3.66	50	6	12,000





# テーパボールエンドミル

## 2-Flute Taper Ball End Mill

# ATBES-2

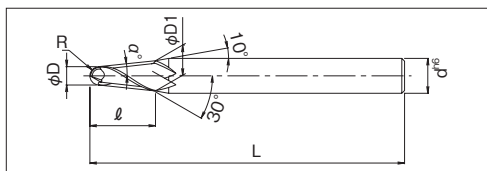

■ 最大テーパ角15° まで標準化した小径テーパボールエンドミルです。

Micro Taper Ball End Mill with largest taper angle to 15°

外径公差	R公差
φD Tolerance	R Tolerance
+0~-0.015	+0~-0.005
+0~-0.025	+0~-0.01
+0~-0.035	+0~-0.015

RO.05~0.45  
RO.5~0.95  
R1~1.5



単位 Unit : mm

型番 CODE NUMBER	R	刃長 ℓ	片角 α°	大端径 φD1	全長 L	シャンク φd	定価 ¥
ATBES-20101	0.05	0.5	30°	0.11	35	3	33,300
ATBES-20102	0.05	0.5	1°	0.12	35	3	33,300
ATBES-20103	0.05	0.5	1°30'	0.12	35	3	33,300
ATBES-20104	0.05	0.5	2°	0.13	35	3	33,300
ATBES-20105	0.05	0.5	2°30'	0.14	35	3	33,300
ATBES-20106	0.05	0.5	3°	0.15	35	3	33,300
ATBES-20107	0.05	0.5	4°	0.16	35	3	33,300
ATBES-20108	0.05	0.5	5°	0.18	35	3	34,800
ATBES-20109	0.05	0.5	7°	0.21	35	3	34,800
ATBES-20110	0.05	0.5	10°	0.26	35	3	36,700
ATBES-20111	0.05	0.5	15°	0.34	35	3	42,200
ATBES-20201	0.1	1	30°	0.22	35	3	33,300
ATBES-20202	0.1	1	1°	0.23	35	3	33,300
ATBES-20203	0.1	1	1°30'	0.25	35	3	33,300
ATBES-20204	0.1	1	2°	0.26	35	3	33,300
ATBES-20205	0.1	1	2°30'	0.28	35	3	33,300
ATBES-20206	0.1	1	3°	0.29	35	3	33,300
ATBES-20207	0.1	1	4°	0.33	35	3	33,300
ATBES-20208	0.1	1	5°	0.36	35	3	34,200
ATBES-20209	0.1	1	7°	0.42	35	3	34,200
ATBES-20210	0.1	1	10°	0.52	35	3	35,800
ATBES-20211	0.1	1	15°	0.69	35	3	38,300
ATBES-20301	0.15	1.5	30°	0.32	35	3	21,700
ATBES-20302	0.15	1.5	1°	0.35	35	3	21,700
ATBES-20303	0.15	1.5	1°30'	0.37	35	3	21,700
ATBES-20304	0.15	1.5	2°	0.39	35	3	21,700
ATBES-20305	0.15	1.5	2°30'	0.42	35	3	21,700

単位 Unit : mm

型番 CODE NUMBER	R	刃長 ℓ	片角 α°	大端径 φD1	全長 L	シャンク φd	定価 ¥
ATBES-20306	0.15	1.5	3°	0.44	35	3	21,700
ATBES-20307	0.15	1.5	4°	0.49	35	3	21,700
ATBES-20308	0.15	1.5	5°	0.54	35	3	22,700
ATBES-20309	0.15	1.5	7°	0.63	35	3	22,700
ATBES-20310	0.15	1.5	10°	0.78	35	3	26,000
ATBES-20311	0.15	1.5	15°	1.03	35	3	28,800
ATBES-20401	0.2	2	30'	0.43	35	3	21,500
ATBES-20402	0.2	2	1°	0.46	35	3	21,500
ATBES-20403	0.2	2	1°30'	0.49	35	3	21,500
ATBES-20404	0.2	2	2°	0.53	35	3	21,500
ATBES-20405	0.2	2	2°30'	0.56	35	3	21,500
ATBES-20406	0.2	2	3°	0.59	35	3	21,500
ATBES-20407	0.2	2	4°	0.65	35	3	21,500
ATBES-20408	0.2	2	5°	0.72	35	3	22,700
ATBES-20409	0.2	2	7°	0.85	35	3	22,700
ATBES-20410	0.2	2	10°	1.04	35	3	26,000
ATBES-20411	0.2	2	15°	1.38	35	3	28,800
ATBES-20501	0.25	2	30'	0.53	35	3	20,200
ATBES-20502	0.25	2	1°	0.56	35	3	20,200
ATBES-20503	0.25	2	1°30'	0.59	35	3	20,200
ATBES-20504	0.25	2	2°	0.62	35	3	20,200
ATBES-20505	0.25	2	2°30'	0.65	35	3	20,200
ATBES-20506	0.25	2	3°	0.68	35	3	20,200
ATBES-20507	0.25	2	4°	0.75	35	3	20,200
ATBES-20508	0.25	2	5°	0.81	35	3	21,700
ATBES-20509	0.25	2	7°	0.93	35	3	21,700
ATBES-20510	0.25	2	10°	1.12	35	3	24,200
ATBES-20511	0.25	2	15°	1.46	35	3	27,800
ATBES-20601	0.3	3	30'	0.65	35	3	20,200
ATBES-20602	0.3	3	1°	0.69	35	3	20,200
ATBES-20603	0.3	3	1°30'	0.74	35	3	20,200
ATBES-20604	0.3	3	2°	0.79	35	3	20,200
ATBES-20605	0.3	3	2°30'	0.84	35	3	20,200
ATBES-20606	0.3	3	3°	0.88	35	3	20,200
ATBES-20607	0.3	3	4°	0.98	35	3	20,200
ATBES-20608	0.3	3	5°	1.07	35	3	21,700
ATBES-20609	0.3	3	7°	1.27	35	3	21,700
ATBES-20610	0.3	3	10°	1.56	35	3	24,200
ATBES-20611	0.3	3	15°	2.07	35	3	27,800
ATBES-20701	0.35	3	30'	0.75	35	3	19,000
ATBES-20702	0.35	3	1°	0.79	35	3	19,000
ATBES-20703	0.35	3	1°30'	0.84	35	3	19,000
ATBES-20704	0.35	3	2°	0.89	35	3	19,000
ATBES-20705	0.35	3	2°30'	0.93	35	3	19,000

Next Page ▶

型番 CODE NUMBER	R	刃長 ℓ	片角 α°	大端径 φD1	全長 L	シャンク φd	定価 ¥
ATBES-20706	0.35	3	3°	0.98	35	3	19,000
ATBES-20707	0.35	3	4°	1.07	35	3	19,000
ATBES-20708	0.35	3	5°	1.17	35	3	19,000
ATBES-20709	0.35	3	7°	1.36	35	3	20,500
ATBES-20710	0.35	3	10°	1.65	35	3	20,500
ATBES-20711	0.35	3	15°	2.14	35	3	24,200
ATBES-20801	0.4	4	30'	0.86	35	3	19,000
ATBES-20802	0.4	4	1°	0.93	35	3	19,000
ATBES-20803	0.4	4	1°30'	0.99	35	3	19,000
ATBES-20804	0.4	4	2°	1.05	35	3	19,000
ATBES-20805	0.4	4	2°30'	1.12	35	3	19,000
ATBES-20806	0.4	4	3°	1.18	35	3	19,000
ATBES-20807	0.4	4	4°	1.31	35	3	19,000
ATBES-20808	0.4	4	5°	1.43	35	3	19,000
ATBES-20809	0.4	4	7°	1.69	35	3	20,500
ATBES-20810	0.4	4	10°	2.08	35	3	20,500
ATBES-20811	0.4	4	15°	2.76	35	3	24,200
ATBES-20901	0.45	4	30'	0.96	35	3	17,500
ATBES-20902	0.45	4	1°	1.02	35	3	17,500
ATBES-20903	0.45	4	1°30'	1.09	35	3	17,500
ATBES-20904	0.45	4	2°	1.15	35	3	17,500
ATBES-20905	0.45	4	2°30'	1.21	35	3	17,500
ATBES-20906	0.45	4	3°	1.27	35	3	17,500
ATBES-20907	0.45	4	4°	1.4	35	3	17,500
ATBES-20908	0.45	4	5°	1.52	35	3	19,000
ATBES-20909	0.45	4	7°	1.78	35	3	20,500
ATBES-20910	0.45	4	10°	2.17	35	3	20,500
ATBES-20911	0.45	4	15°	2.83	35	3	24,200
ATBES-21001	0.5	8	30'	1.13	50	4	16,300
ATBES-21002	0.5	8	1°	1.26	50	4	16,300
ATBES-21003	0.5	8	1°30'	1.39	50	4	16,300
ATBES-21004	0.5	8	2°	1.52	50	4	16,300
ATBES-21005	0.5	8	2°30'	1.66	50	4	16,300
ATBES-21006	0.5	8	3°	1.79	50	4	16,300
ATBES-21007	0.5	8	4°	2.05	50	4	16,300
ATBES-21008	0.5	8	5°	2.32	50	4	16,300
ATBES-21009	0.5	8	7°	2.85	50	4	17,000
ATBES-21010	0.5	8	10°	3.66	50	4	18,300
ATBES-21011	0.5	8	15°	5.05	50	6	23,000
ATBES-21101	0.55	8	30'	1.23	50	4	17,000
ATBES-21102	0.55	8	1°	1.36	50	4	17,000
ATBES-21103	0.55	8	1°30'	1.49	50	4	17,000
ATBES-21104	0.55	8	2°	1.62	50	4	17,000
ATBES-21105	0.55	8	2°30'	1.75	50	4	17,000

単位 Unit : mm

型番 CODE NUMBER	R	刃長 ℓ	片角 α°	大端径 φD1	全長 L	シャンク φd	定価 ¥
ATBES-21106	0.55	8	3°	1.88	50	4	17,000
ATBES-21107	0.55	8	4°	2.14	50	4	17,000
ATBES-21108	0.55	8	5°	2.41	50	4	17,000
ATBES-21109	0.55	8	7°	2.94	50	4	19,800
ATBES-21110	0.55	8	10°	3.74	50	4	19,800
ATBES-21111	0.55	8	15°	5.13	50	6	23,000
ATBES-21201	0.6	8	30'	1.33	50	4	17,000
ATBES-21202	0.6	8	1°	1.46	50	4	17,000
ATBES-21203	0.6	8	1°30'	1.59	50	4	17,000
ATBES-21204	0.6	8	2°	1.72	50	4	17,000
ATBES-21205	0.6	8	2°30'	1.85	50	4	17,000
ATBES-21206	0.6	8	3°	1.98	50	4	17,000
ATBES-21207	0.6	8	4°	2.24	50	4	17,000
ATBES-21208	0.6	8	5°	2.5	50	4	17,000
ATBES-21209	0.6	8	7°	3.03	50	4	19,800
ATBES-21210	0.6	8	10°	3.83	50	4	19,800
ATBES-21211	0.6	8	15°	5.21	50	6	23,000
ATBES-21301	0.65	8	30'	1.43	50	4	17,000
ATBES-21302	0.65	8	1°	1.56	50	4	17,000
ATBES-21303	0.65	8	1°30'	1.69	50	4	17,000
ATBES-21304	0.65	8	2°	1.81	50	4	17,000
ATBES-21305	0.65	8	2°30'	1.94	50	4	17,000
ATBES-21306	0.65	8	3°	2.07	50	4	17,000
ATBES-21307	0.65	8	4°	2.33	50	4	17,000
ATBES-21308	0.65	8	5°	2.59	50	4	17,000
ATBES-21309	0.65	8	7°	3.11	50	4	19,800
ATBES-21310	0.65	8	10°	3.91	50	4	19,800
ATBES-21311	0.65	8	15°	5.28	50	6	23,000
ATBES-21401	0.7	8	30'	1.53	50	4	17,000
ATBES-21402	0.7	8	1°	1.66	50	4	17,000
ATBES-21403	0.7	8	1°30'	1.78	50	4	17,000
ATBES-21404	0.7	8	2°	1.91	50	4	17,000
ATBES-21405	0.7	8	2°30'	2.04	50	4	17,000
ATBES-21406	0.7	8	3°	2.17	50	4	17,000
ATBES-21407	0.7	8	4°	2.42	50	4	17,000
ATBES-21408	0.7	8	5°	2.68	50	4	17,000
ATBES-21409	0.7	8	7°	3.2	50	4	19,700
ATBES-21410	0.7	8	10°	4	50	4	19,700
ATBES-21411	0.7	8	15°	5.36	50	6	23,000
ATBES-21501	0.75	8	30'	1.63	50	4	15,000
ATBES-21502	0.75	8	1°	1.75	50	4	15,000
ATBES-21503	0.75	8	1°30'	1.88	50	4	15,000
ATBES-21504	0.75	8	2°	2.01	50	4	15,000
ATBES-21505	0.75	8	2°30'	2.13	50	4	15,000

Next Page ▶

型番 CODE NUMBER	R	刃長 ℓ	片角 α°	大端径 φD1	全長 L	シャンク φd	定価 ¥
ATBES-21506	0.75	8	3°	2.26	50	4	15,000
ATBES-21507	0.75	8	4°	2.52	50	4	15,000
ATBES-21508	0.75	8	5°	2.77	50	4	15,000
ATBES-21509	0.75	8	7°	3.29	50	4	15,000
ATBES-21510	0.75	8	10°	4.08	50	6	17,800
ATBES-21511	0.75	8	15°	5.44	50	6	20,500
ATBES-21601	0.8	8	30'	1.73	50	4	15,800
ATBES-21602	0.8	8	1°	1.85	50	4	15,800
ATBES-21603	0.8	8	1°30'	1.98	50	4	15,800
ATBES-21604	0.8	8	2°	2.1	50	4	15,800
ATBES-21605	0.8	8	2°30'	2.23	50	4	15,800
ATBES-21606	0.8	8	3°	2.36	50	4	15,800
ATBES-21607	0.8	8	4°	2.61	50	4	15,800
ATBES-21608	0.8	8	5°	2.87	50	4	15,800
ATBES-21609	0.8	8	7°	3.38	50	4	18,000
ATBES-21610	0.8	8	10°	4.16	50	6	18,000
ATBES-21611	0.8	8	15°	5.51	50	6	20,500
ATBES-21701	0.85	8	30'	1.82	50	4	15,800
ATBES-21702	0.85	8	1°	1.95	50	4	15,800
ATBES-21703	0.85	8	1°30'	2.08	50	4	15,800
ATBES-21704	0.85	8	2°	2.2	50	4	15,800
ATBES-21705	0.85	8	2°30'	2.33	50	4	15,800
ATBES-21706	0.85	8	3°	2.45	50	4	15,800
ATBES-21707	0.85	8	4°	2.7	50	4	15,800
ATBES-21708	0.85	8	5°	2.96	50	4	15,800
ATBES-21709	0.85	8	7°	3.47	50	4	18,000
ATBES-21710	0.85	8	10°	4.25	50	6	18,000
ATBES-21711	0.85	8	15°	5.59	50	6	20,500
ATBES-21801	0.9	8	30'	1.92	50	4	15,800
ATBES-21802	0.9	8	1°	2.05	50	4	15,800
ATBES-21803	0.9	8	1°30'	2.17	50	4	15,800
ATBES-21804	0.9	8	2°	2.3	50	4	15,800
ATBES-21805	0.9	8	2°30'	2.42	50	4	15,800
ATBES-21806	0.9	8	3°	2.55	50	4	15,800
ATBES-21807	0.9	8	4°	2.8	50	4	15,800
ATBES-21808	0.9	8	5°	3.05	50	4	15,800
ATBES-21809	0.9	8	7°	3.56	50	4	18,000
ATBES-21810	0.9	8	10°	4.33	50	6	18,000
ATBES-21811	0.9	8	15°	5.67	50	6	20,500
ATBES-21901	0.95	8	30'	2.02	50	4	15,800
ATBES-21902	0.95	8	1°	2.15	50	4	15,800
ATBES-21903	0.95	8	1°30'	2.27	50	4	15,800
ATBES-21904	0.95	8	2°	2.39	50	4	15,800
ATBES-21905	0.95	8	2°30'	2.52	50	4	15,800

単位 Unit : mm

型番 CODE NUMBER	R	刃長 ℓ	片角 α°	大端径 φD1	全長 L	シャンク φd	定価 ¥
ATBES-21906	0.95	8	3°	2.64	50	4	15,800
ATBES-21907	0.95	8	4°	2.89	50	4	15,800
ATBES-21908	0.95	8	5°	3.14	50	4	15,800
ATBES-21909	0.95	8	7°	3.65	50	4	17,800
ATBES-21910	0.95	8	10°	4.42	50	6	17,800
ATBES-21911	0.95	8	15°	5.75	50	6	20,500
ATBES-22001	1	12	30'	2.19	55	4	12,800
ATBES-22002	1	12	1°	2.38	55	4	12,800
ATBES-22003	1	12	1°30'	2.58	55	4	12,800
ATBES-22004	1	12	2°	2.77	55	4	12,800
ATBES-22005	1	12	2°30'	2.96	55	4	12,800
ATBES-22006	1	12	3°	3.16	55	4	12,800
ATBES-22007	1	12	4°	3.54	55	4	16,500
ATBES-22008	1	12	5°	3.93	55	4	16,500
ATBES-22009	1	12	7°	4.72	55	6	16,500
ATBES-22010	1	12	10°	5.91	55	6	19,700
ATBES-22011	1	12	15°	7.97	55	8	22,000
ATBES-22101	1.05	12	30'	2.29	55	4	12,800
ATBES-22102	1.05	12	1°	2.48	55	4	12,800
ATBES-22103	1.05	12	1°30'	2.67	55	4	12,800
ATBES-22104	1.05	12	2°	2.87	55	4	12,800
ATBES-22105	1.05	12	2°30'	3.06	55	4	12,800
ATBES-22106	1.05	12	3°	3.25	55	4	12,800
ATBES-22107	1.05	12	4°	3.64	55	4	16,500
ATBES-22108	1.05	12	5°	4.02	55	6	16,500
ATBES-22109	1.05	12	7°	4.8	55	6	16,500
ATBES-22110	1.05	12	10°	5.99	55	6	19,700
ATBES-22111	1.05	12	15°	8.04	55	10	22,000
ATBES-22201	1.1	12	30'	2.39	55	4	12,800
ATBES-22202	1.1	12	1°	2.58	55	4	12,800
ATBES-22203	1.1	12	1°30'	2.77	55	4	12,800
ATBES-22204	1.1	12	2°	2.96	55	4	12,800
ATBES-22205	1.1	12	2°30'	3.15	55	4	12,800
ATBES-22206	1.1	12	3°	3.35	55	4	12,800
ATBES-22207	1.1	12	4°	3.73	55	4	16,500
ATBES-22208	1.1	12	5°	4.12	55	6	16,500
ATBES-22209	1.1	12	7°	4.89	55	6	16,500
ATBES-22210	1.1	12	10°	6.08	55	8	19,700
ATBES-22211	1.1	12	15°	8.12	55	10	22,000
ATBES-22301	1.15	12	30'	2.49	55	4	12,800
ATBES-22302	1.15	12	1°	2.68	55	4	12,800
ATBES-22303	1.15	12	1°30'	2.87	55	4	12,800
ATBES-22304	1.15	12	2°	3.06	55	4	12,800
ATBES-22305	1.15	12	2°30'	3.25	55	4	12,800

Next Page ▶

型番 CODE NUMBER	R	刃長 $l$	片角 $\alpha^\circ$	大端径 φD1	全長 L	シャンク φd	定価 ¥
ATBES-22306	1.15	12	3°	3.44	55	4	12,800
ATBES-22307	1.15	12	4°	3.82	55	4	16,500
ATBES-22308	1.15	12	5°	4.21	55	6	16,500
ATBES-22309	1.15	12	7°	4.98	55	6	16,500
ATBES-22310	1.15	12	10°	6.16	55	8	19,700
ATBES-22311	1.15	12	15°	8.2	55	10	22,000
ATBES-22401	1.2	12	30'	2.59	55	4	12,800
ATBES-22402	1.2	12	1°	2.78	55	4	12,800
ATBES-22403	1.2	12	1°30'	2.97	55	4	12,800
ATBES-22404	1.2	12	2°	3.16	55	4	12,800
ATBES-22405	1.2	12	2°30'	3.35	55	4	12,800
ATBES-22406	1.2	12	3°	3.54	55	4	12,800
ATBES-22407	1.2	12	4°	3.92	55	4	16,500
ATBES-22408	1.2	12	5°	4.3	55	6	16,500
ATBES-22409	1.2	12	7°	5.07	55	6	16,500
ATBES-22410	1.2	12	10°	6.25	55	8	19,700
ATBES-22411	1.2	12	15°	8.27	55	10	22,000
ATBES-22501	1.25	12	30'	2.69	55	4	15,800
ATBES-22502	1.25	12	1°	2.88	55	4	15,800
ATBES-22503	1.25	12	1°30'	3.06	55	4	15,800
ATBES-22504	1.25	12	2°	3.25	55	4	15,800
ATBES-22505	1.25	12	2°30'	3.44	55	4	15,800
ATBES-22506	1.25	12	3°	3.63	55	4	15,800
ATBES-22507	1.25	12	4°	4.01	55	6	15,800
ATBES-22508	1.25	12	5°	4.39	55	6	16,700
ATBES-22509	1.25	12	7°	5.16	55	6	16,700
ATBES-22510	1.25	12	10°	6.33	55	8	21,200
ATBES-22511	1.25	12	15°	8.35	55	10	24,200
ATBES-22601	1.3	12	30'	2.79	55	4	15,800
ATBES-22602	1.3	12	1°	2.97	55	4	15,800
ATBES-22603	1.3	12	1°30'	3.16	55	4	15,800
ATBES-22604	1.3	12	2°	3.35	55	4	15,800
ATBES-22605	1.3	12	2°30'	3.54	55	4	15,800
ATBES-22606	1.3	12	3°	3.73	55	4	15,800
ATBES-22607	1.3	12	4°	4.1	55	6	15,800
ATBES-22608	1.3	12	5°	4.48	55	6	17,500
ATBES-22609	1.3	12	7°	5.25	55	6	17,500
ATBES-22610	1.3	12	10°	6.41	55	8	19,700
ATBES-22611	1.3	12	15°	8.43	55	10	24,200
ATBES-22701	1.35	12	30'	2.89	55	4	15,800
ATBES-22702	1.35	12	1°	3.07	55	4	15,800
ATBES-22703	1.35	12	1°30'	3.26	55	4	15,800
ATBES-22704	1.35	12	2°	3.45	55	4	15,800
ATBES-22705	1.35	12	2°30'	3.63	55	4	15,800







# コーナーRカッター (2枚刃)

## 2-Flute Corner Radius Cutter

# ACR

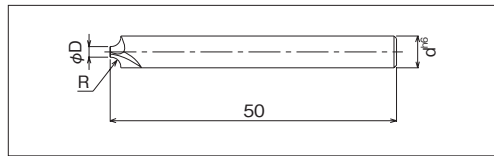

※刃部詳細図はP.180参照

■ 精密加工用高精度インナーRカッターです。

High precision inner radius cutter for fine processing.

R公差：±0.02

R Tolerance



単位 Unit : mm

型番 CODE NUMBER	R	先端径 φD	全長 L	シャンク d	定価 ¥
ACR-2010	0.1	1	50	3	13,500
ACR-2015	0.15	1	50	3	13,500
ACR-2020	0.2	1	50	3	11,700
ACR-2025	0.25	1	50	3	11,700
ACR-2030	0.3	1	50	3	11,700
ACR-2035	0.35	1	50	3	11,700
ACR-2040	0.4	1	50	3	10,000
ACR-2045	0.45	1	50	3	10,000
ACR-2050	0.5	1	50	3	7,300
ACR-2055	0.55	1	50	3	8,200
ACR-2060	0.6	1.5	50	4	8,200
ACR-2065	0.65	1.5	50	4	8,200
ACR-2070	0.7	1.5	50	4	8,200
ACR-2075	0.75	1.5	50	4	7,300
ACR-2080	0.8	1.5	50	4	8,200
ACR-2085	0.85	1.5	50	4	8,200
ACR-2090	0.9	1.5	50	4	8,200
ACR-2095	0.95	1.5	50	4	8,200
ACR-2100	1	1.5	50	4	7,300
ACR-2105	1.05	1.5	50	4	8,200
ACR-2110	1.1	2	50	6	8,200
ACR-2115	1.15	2	50	6	8,200
ACR-2120	1.2	2	50	6	8,200
ACR-2125	1.25	2	50	6	7,300
ACR-2130	1.3	2	50	6	12,200
ACR-2135	1.35	2	50	6	12,200
ACR-2140	1.4	2	50	6	12,200

型番 CODE NUMBER	R	先端径 φD	全長 L	シャンク d	定価 ¥
ACR-2145	1.45	2	50	6	12,200
ACR-2150	1.5	2	50	6	11,200
ACR-2155	1.55	2	50	6	12,200
ACR-2160	1.6	2	50	6	12,200
ACR-2165	1.65	2	50	6	12,200
ACR-2170	1.7	2	50	6	12,200
ACR-2175	1.75	2	50	6	11,200
ACR-2180	1.8	2	50	6	12,200
ACR-2185	1.85	2.5	50	8	13,700
ACR-2190	1.9	2.5	50	8	13,700
ACR-2195	1.95	2.5	50	8	13,700
ACR-2200	2	2.5	50	8	11,200
ACR-2205	2.05	2.5	50	8	13,700
ACR-2210	2.1	2.5	50	8	13,700
ACR-2215	2.15	2.5	50	8	13,700
ACR-2220	2.2	2.5	50	8	13,700
ACR-2225	2.25	2.5	50	8	13,700
ACR-2230	2.3	2.5	50	8	13,700
ACR-2235	2.35	2.5	50	8	13,700
ACR-2240	2.4	2.5	50	8	13,700
ACR-2245	2.45	2.5	50	8	13,700
ACR-2250	2.5	2.5	50	8	11,700







始めに「ハード」あり!

確かな物造りの眼で裏打ちされたATOMブランドは高い信頼を培う。  
高度な技術力と蓄積されたノウハウがここに結集する。

社会と密接につながる私達は、  
あらゆる分野に優れたオンリーワンと呼ばれる製品をお届けします。

First of All, let there be "hardware"!

ATOM win public confidence in our reliable technical service.

Highly developed technical skills  
and accumulated engineering know-hows are concentrated here.

We, who are in close relation to the society,  
promise outstanding products called "Only One" in every field.

**ATOM** 難削材用マイクロドリル  
**ADR-SUSマイクロドリル**  
FCSコーティング  
ADR-SUS MICRO DRILL FOR STAINLESS STEEL  
Coated Tungsten Carbide Drill

**長寿命 Long Tool Life**  
超硬質コーティング  
高剛性・高強度  
高速度・高進捗  
高寿命・高信頼性  
高剛性・高強度  
高速度・高進捗  
高寿命・高信頼性

**高精度 High Precision**  
0.01mm超精密加工  
高精度・高信頼性  
高剛性・高強度  
高速度・高進捗  
高寿命・高信頼性

**高剛性 High Stiffness**  
高剛性・高強度  
高速度・高進捗  
高寿命・高信頼性

ATOM 株式会社 東京都中央区新富1-1-1 TEL: 03-5561-1111

**ATOM** ミクロンオーダーの超精密・難削加工に  
**ADR-SPハイ・スぺックドリル**  
超硬コーティング  
ADR-SP SUPER PRECISION DRILL, TUNGSTEN CARBIDE

ドリル径公差 ミクロン以下  $\pm 0.003$   
Tolerance of 0.003mm  $\pm 0.003$

$\pm 0.025$   $\pm 0.035$   $\pm 0.045$   $\pm 0.055$   $\pm 0.065$   $\pm 0.075$   $\pm 0.085$   $\pm 0.095$   $\pm 0.105$   $\pm 0.115$

0.01mmとマイクロシリーズの中間サイズを標準化  
ドリル径 $\phi 0.035$ ~ $\phi 1.995$ mmまで  
Standard size between 0.01mm and micro series  
From  $\phi 0.035$  up to  $\phi 1.995$ mm

ATOM 株式会社 東京都中央区新富1-1-1 TEL: 03-5561-1111

**ATOM** 鋼材細穴加工用 [Cコーティング]  
**マイクロドリル**  
**"NEO-PRO"シリーズ**  
Micro Drill "NEO-PRO" Series, for Steels Coated Solid Carbide Drill

超硬コーティング  
高剛性・高強度  
高速度・高進捗  
高寿命・高信頼性

標準品 0.035mm~ $\phi 1.995$ mm  
標準品 0.035mm~ $\phi 1.995$ mm

ATOM 株式会社 東京都中央区新富1-1-1 TEL: 03-5561-1111

# ドリル・エンドミル 切削条件表

Drilling Conditions  
Milling Conditions

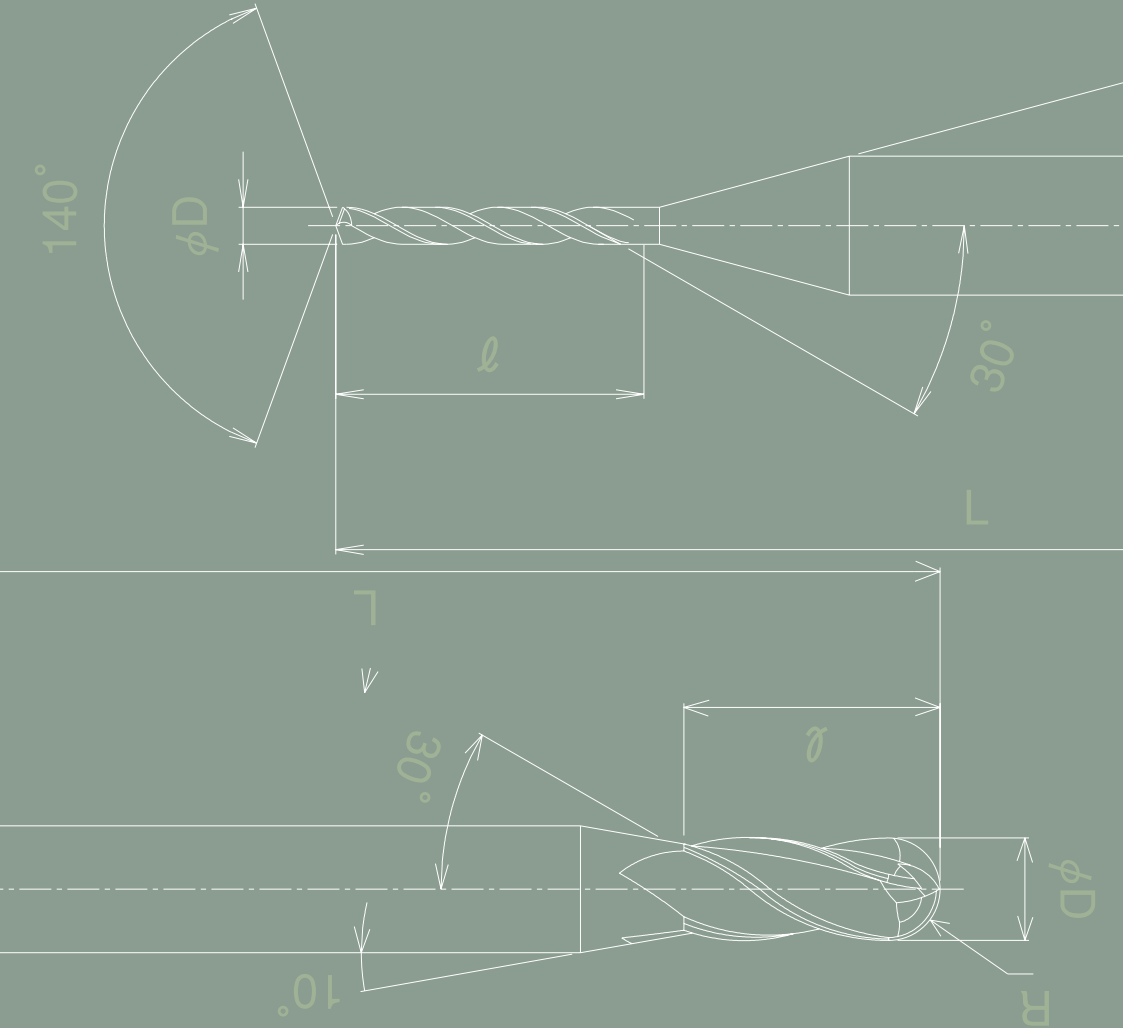

# ADPF30/ADPF309/ADPF31/V-ADPF30/V-ADPF309/V-ADPF31 NC ポインティング ドリル 鋼材用 NC Pointing Drill for Ferrous Material

被削材 Work Materials	炭素鋼・合金鋼・工具鋼 Steel						ステンレス Stainless Steel			
	炭素鋼 Carbon steel SS S50C		合金鋼 Alloy Steel SCM SKS		調質鋼 Hardened Steel NAK SKD (HRC30~38)		SUS304等 オーステナイト系 SUS304/316 Austenitic		マルテンサイト・ フェライト系 SUS420/430 Martensitic & Ferritic	
条件 先端径	回転数 Rotation (min <sup>-1</sup> )	送り量 Feed (mm/rev)	回転数 Rotation (min <sup>-1</sup> )	送り量 Feed (mm/rev)	回転数 Rotation (min <sup>-1</sup> )	送り量 Feed (mm/rev)	回転数 Rotation (min <sup>-1</sup> )	送り量 Feed (mm/rev)	回転数 Rotation (min <sup>-1</sup> )	送り量 Feed (mm/rev)
φ0.03~ 0.09	10,000→ 20,000	0.001~ 0.0015	10,000→ 20,000	0.001~ 0.0015	10,000→ 20,000	0.001	10,000→ 20,000	0.0005~ 0.001	10,000→ 20,000	0.001~ 0.002
φ0.1~ 0.29	15,000~ 10,000	0.0015~ 0.007	15,000~ 10,000	0.0015~ 0.007	13,000~ 8,800	0.001~ 0.004	10,000~ 5,000	0.001~ 0.003	13,000~ 8,800	0.0005~ 0.001
φ0.3~ 0.49	10,000~ 9,500	0.007~ 0.01	10,000~ 9,500	0.007~ 0.01	8,800~ 6,500	0.003~ 0.005	5,000~ 4,500	0.001~ 0.005	8,800~ 6,500	0.001~ 0.005
φ0.5~ 0.99	9,500~ 7,700	0.01~ 0.02	9,500~ 7,700	0.01~ 0.02	6,500~ 4,800	0.005~ 0.01	4,500~ 3,200	0.005~ 0.01	6,500~ 4,800	0.005~ 0.01
φ1~ 1.99	7,700~ 5,100	0.02~ 0.05	7,700~ 5,100	0.02~ 0.05	3,100~ 2,400	0.01~ 0.03	3,200~ 2,400	0.01~ 0.03	4,800~ 3,200	0.01~ 0.03
φ2.0~ 3.0	5,100~ 4,200	0.06	5,100~ 4,200	0.06	2,400~ 1,600	0.02~ 0.04	2,400~ 1,800	0.03~ 0.05	3,200~ 2,100	0.03~ 0.05

# ADPN30/ADPN309/ADPN31 NC ポインティング ドリル 非鉄・樹脂用 NC Pointing Drill for Non-Ferrous Material

- ▶ステップ送り量: φ0.03~φ0.4:ドリル径×  
Step Feed 10% (0.1D)  
φ0.5~φ1.0:ドリル径×  
20% (0.2D)  
φ1.0以上:ドリル径×25%  
~50%(0.25~0.5D)

●百分台の回転数10,000~20,000の表示は低回転数(10,000)から加工を始めていただくことを推奨しています  
For the drill diameter under 0.1mm, you are recommended to start machining with low rotation speed indicated on this table.

## 備考

- 1) チャッキング時のドリル振れ精度は0.003mm以下に抑えて下さい。
- 2) ご使用の機械の最高回転数が上記切削条件に達しない場合は、なるべく安定領域での高い回転数でご使用下さい。  
その場合送り量も同じ比率で下げて下さい。
- 3) ドリルφ0.5以下ご使用の場合は、上記切削条件よりもご使用のスピンダル精度が最も安定する回転数を優先させて下さい。

## Remarks:

- 1) The run out with a drill in a spindle should be minimized to less than 0.003mm.
- 2) When machines can not achieve a recommended rotation speed, please set maximum speed but in stable rotation range and adjust the feed rate.
- 3) For smaller drills under φ0.5, the most stable rotation speed of actually using spindle has higher priority than recommended conditions shown in the table.

被削材 Work Materials	非鉄金属 Non-Ferrous				樹脂 Resin	
	アルミ合金 Aluminium Alloy		銅合金 Copper Alloy		エンジニア Engineering Plastic	
条件 先端径	回転数 Rotation (min <sup>-1</sup> )	送り量 Feed (mm/rev)	回転数 Rotation (min <sup>-1</sup> )	送り量 Feed (mm/rev)	回転数 Rotation (min <sup>-1</sup> )	送り量 Feed (mm/rev)
φ0.03~ 0.09	10,000→ 20,000	0.002~ 0.005	10,000→ 20,000	0.002~ 0.005	10,000→ 20,000	0.002~ 0.005
φ0.1~ 0.29	18,000~ 13,000	0.005~ 0.02	16,000~ 11,000	0.002~ 0.008	18,000~ 13,000	0.005~ 0.02
φ0.3~ 0.49	13,000~ 10,000	0.02~ 0.03	11,000~ 11,500	0.008~ 0.015	13,000~ 10,000	0.02~ 0.03
φ0.5~ 0.99	10,000	0.03	11,500~ 9,600	0.015~ 0.04	10,000	0.03
φ1~ 1.99	10,000~ 5,100	0.03~ 0.04	9,600~ 4,800	0.04~ 0.08	10,000~ 5,100	0.03~ 0.04
φ2.0~ 3.0	5,100~ 4,200	0.04	4,800~ 4,200	0.08~ 0.15	5,100~ 4,200	0.04



# ADR/ADRS/ADRSL/ADRL/ADR-SP/AMSD/ADR-h4/ADR31 ルーマ型ドリルシリーズ

## Micro Drill with Common Shank Series

被削材 Work Materials	炭素鋼・合金鋼・工具鋼 Steel						ステンレス Stainless Steel			
	炭素鋼 Carbon steel SS S50C		合金鋼 Alloy Steel SCM SKS		調質鋼 Hardened Steel NAK SKD (HRC30~38)		SUS304等 オーステナイト系 SUS304/316 Austenitic		マルテンサイト・ フェライト系 SUS420/430 Martensitic & Ferritic	
条件	回転数 Rotation (min <sup>-1</sup> )	送り量 Feed (mm/rev)	回転数 Rotation (min <sup>-1</sup> )	送り量 Feed (mm/rev)	回転数 Rotation (min <sup>-1</sup> )	送り量 Feed (mm/rev)	回転数 Rotation (min <sup>-1</sup> )	送り量 Feed (mm/rev)	回転数 Rotation (min <sup>-1</sup> )	送り量 Feed (mm/rev)
先端径										
φ0.02~ 0.09	10,000→ 20,000	0.001~ 0.0015	10,000→ 20,000	0.001~ 0.0015	10,000→ 20,000	0.001	10,000→ 20,000	0.0005~ 0.001	10,000→ 20,000	0.001~ 0.0015
φ0.1~ 0.29	19,000~ 13,000	0.002~ 0.01	16,000~ 11,000	0.0014~ 0.007	13,000~ 8,800	0.001~ 0.004	10,000~ 5,000	0.0005~ 0.001	13,000~ 8,800	0.0005~ 0.001
φ0.3~ 0.49	13,000~ 12,000	0.01~ 0.02	11,000~ 9,700	0.007~ 0.01	8,800~ 6,500	0.003~ 0.005	5,000~ 4,500	0.001~ 0.005	8,800~ 6,500	0.001~ 0.005
φ0.5~ 0.99	12,000~ 9,600	0.02~ 0.04	9,700~ 6,400	0.01~ 0.02	6,500~ 4,800	0.005~ 0.01	4,500~ 3,200	0.005~ 0.01	6,500~ 4,800	0.005~ 0.01
φ1~ 1.99	9,600~ 6,400	0.03~ 0.06	6,400~ 4,000	0.02~ 0.05	3,100~ 2,400	0.01~ 0.03	3,200~ 2,400	0.01~ 0.03	4,800~ 3,200	0.01~ 0.03
φ2.0~ 3.0	6,400~ 4,200	0.07~ 0.1	4,000~ 3,200	0.05~ 0.08	2,400~ 1,600	0.02~ 0.04	2,400~ 1,800	0.03~ 0.05	3,200~ 2,100	0.03~ 0.05

被削材 Work Materials	非鉄金属 Non-Ferrous				樹脂 Resin	
	アルミ合金 Aluminium Alloy		銅合金 Copper Alloy		エンジニア Engineering Plastic	
条件	回転数 Rotation (min <sup>-1</sup> )	送り量 Feed (mm/rev)	回転数 Rotation (min <sup>-1</sup> )	送り量 Feed (mm/rev)	回転数 Rotation (min <sup>-1</sup> )	送り量 Feed (mm/rev)
先端径						
φ0.02~ 0.09	10,000→ 30,000	0.001~ 0.003	10,000→ 20,000	0.001~ 0.005	10,000→ 20,000	0.001~ 0.003
φ0.1~ 0.29	22,200~ 16,500	0.005~ 0.02	16,000~ 11,000	0.002~ 0.008	20,000~ 15,000	0.005~ 0.01
φ0.3~ 0.49	16,500~ 13,000	0.02~ 0.04	11,000~ 11,500	0.008~ 0.015	15000	0.01~ 0.02
φ0.5~ 0.99	13,000~ 12,700	0.04~ 0.06	11,500~ 9,600	0.015~ 0.04	15,000~ 10,000	0.02~ 0.04
φ1~ 1.99	12,700~ 6,400	0.06~ 0.12	9,600~ 4,800	0.04~ 0.08	10,000~ 6,000	0.05~ 0.07
φ2.0~ 3.0	6,400~ 5,300	0.12~ 0.2	4,800~ 4,200	0.08~ 0.15	6,000~ 5,000	0.07~ 0.1

- ▶ ステップ送り量: φ0.02~φ0.4: ドリル径  
×10% (0.1D)  
Step Feed φ0.5~φ1.0: ドリル径×  
20% (0.2D)  
φ1.0以上: ドリル径×25  
%~50%(0.25~0.5D)

## 備考

- 1) 細穴、特にφ1.0以下の穴あけ加工の場合には、ガイド穴(センター穴)を施した上で穴加工を行って下さい。  
ドリル食い付き時の破損・チッピングを防ぎます。
- 2) チャッキング時のドリル振れ精度は0.003mm以下に抑えて下さい。
- 3) ご使用の機械の最高回転数が上記切削条件に達しない場合は、なるべく安定領域での高い回転数でご使用下さい。  
その場合送り量も同じ比率で下げて下さい。
- 4) ドリルφ0.5以下ご使用の場合は、上記切削条件よりもご使用のスピンドル精度が最も安定する回転数を優先させて下さい。

## Remarks:

- 1) When drilling smaller hole, especially under φ1.0mm, the guide hole (positioning by starting drill) is necessary.  
It prevents the drill breakage and initial chipping of cutting edge.
- 2) The run out with a drill in a spindle should be minimized to less than 0.003mm.
- 3) When machines can not achieve a recommended rotation speed, please set maximum speed but in stable rotation range and adjust the feed rate.
- 4) For smaller drills under φ0.5, the most stable rotation speed of actually using spindle has priority over the recommended conditions indicated in the table.

# ADR-SV/ADRS-SV/ADRSL-SV/ADRL-SV マイクロドリル “NEO-PRO” シリーズ 鋼材細穴加工用 Micro Drill “NEO-PRO”Series

被削材 Work Materials	炭素鋼・合金鋼・工具鋼 Steel						ステンレス Stainless Steel			
	炭素鋼 Carbon steel SS S50C		合金鋼 Alloy Steel SCM SKS		調質鋼 Hardened Steel NAK SKD (HRC30~38)		SUS304等 オーステナイト系 SUS304/316 Austenitic		マルテンサイト・ フェライト系 SUS420/430 Martensitic & Ferritic	
条件 先端径	回転数 Rotation (min <sup>-1</sup> )	送り量 Feed (mm/rev)	回転数 Rotation (min <sup>-1</sup> )	送り量 Feed (mm/rev)	回転数 Rotation (min <sup>-1</sup> )	送り量 Feed (mm/rev)	回転数 Rotation (min <sup>-1</sup> )	送り量 Feed (mm/rev)	回転数 Rotation (min <sup>-1</sup> )	送り量 Feed (mm/rev)
φ0.03~ 0.09	10,000→ 20,000	0.001~ 0.0015	10,000→ 20,000	0.001~ 0.0015	10,000→ 20,000	0.001	10,000→ 15,000	0.001~ 0.0015	10,000→ 20,000	0.001~ 0.002
φ0.1~ 0.29	25,000~ 20,000	0.002~ 0.01	20,000~ 15,000	0.0015~ 0.007	17,000~ 13,000	0.001~ 0.004	15,000~ 7,500	0.0005~ 0.001	20,000~ 13,000	0.0005~ 0.001
φ0.3~ 0.49	20,000~ 18,000	0.01~ 0.02	15,000	0.007~ 0.01	13,000~ 10,000	0.003~ 0.005	10,000~ 8,000	0.002~ 0.01	13,000~ 9,500	0.002~ 0.01
φ0.5~ 0.99	18,000~ 15,000	0.02~ 0.04	15,000~ 9,500	0.01~ 0.02	10,000~ 7,000	0.005~ 0.01	8,000~ 6,000	0.015~ 0.02	9,500~ 7,000	0.015~ 0.02
φ1~ 1.99	15,000~ 9,500	0.03~ 0.06	9,500~ 6,000	0.02~ 0.05	7,000~ 4,000	0.01~ 0.03	6,000~ 4,000	0.02~ 0.04	7,000~ 4,000	0.02~ 0.04
φ2.0~ 3.0	9,500~ 6,300	0.07~ 0.1	6,000~ 4,800	0.05~ 0.08	4,000~ 3,000	0.02~ 0.04	4,000~ 3,700	0.03~ 0.05	4,000~ 3,000	0.03~ 0.05

▶ステップ送り量: φ0.03~φ0.4: ドリル径×10%~20% (0.1D~0.2D)

**Step Feed** φ0.5~1.0: ドリル径×20%~30% (0.2D)  
φ1.0 以上: ドリル径×30%~50% (0.3D~0.5D)

#### 備考

- 1) 細穴、特にφ1.0以下の穴あけ加工の場合には、ガイド穴（センター穴）を施した上で穴加工を行って下さい。  
ドリル食い付き時の破損・チッピングを防ぎます。
- 2) チャッキング時のドリル振れ精度は0.003mm以下に抑えて下さい。
- 3) ご使用の機械の最高回転数が上記切削条件に達しない場合は、なるべく安定領域での高い回転数でご使用下さい。  
その場合送り量も同じ比率で下げて下さい。
- 4) ドリルφ0.5以下ご使用の場合は、上記切削条件よりもご使用のスピンドル精度が最も安定する回転数を優先させて下さい。

#### Remarks:

- 1) When drilling smaller hole, especially under φ 1.0mm, the guide hole(positioning by starting drill) is necessary.  
It prevents the drill breakage and initial chipping of cutting edge.
- 2) The run out with a drill in a spindle should be minimized to less than 0.003mm.
- 3) When machines can not achieve a recommended rotation speed, please set maximum speed but in stable rotation range and adjust the feed rate.
- 4) For smaller drills under φ0.5, the most stable rotation speed of actually using spindle has higher priority than recommended conditions shown in the table.

# ADR-SUS/ADRL-SUS 難削材用マイクロドリルシリーズ

## Micro Drill for Hard-to-Cut Materials Series

被削材 Work Materials	ステンレス鋼 STAINLESS STEEL						超耐熱合金 インコネル・ ハステロイ Inconel/ Hasteroy		コバルト Kovar (FE-Ni-Co 合金)	
	オーステナイト系 SUS304/316 Austenitic		マルテンサイト・ フェライト系 SUS420/430 Martensitic & Ferritic		析出硬化系 SUS630 Precipitation		回転数	送り量	回転数	送り量
ドリル径 Drill Dia. (mm)	回転数 Rotation (min <sup>-1</sup> )	送り量 Feed (mm/rev)	回転数 Rotation (min <sup>-1</sup> )	送り量 Feed (mm/rev)	回転数 Rotation (min <sup>-1</sup> )	送り量 Feed (mm/rev)	回転数 Rotation (min <sup>-1</sup> )	送り量 Feed (mm/rev)	回転数 Rotation (min <sup>-1</sup> )	送り量 Feed (mm/rev)
φ0.1～ 0.2	10,000	0.0003～ 0.001	12,500～ 11,200	0.0004～ 0.001	7,100	0.0003～ 0.0008	4,300	0.0003～ 0.0007	9,500	0.0003～ 0.0008
φ0.3～ 0.4	8,500～ 7,900	0.0015～ 0.003	10,500～ 10,000	0.0015～ 0.003	6,400～ 6,000	0.001～ 0.002	3,900～ 3,600	0.001～ 0.002	8,500～ 7,900	0.0015～ 0.003
φ0.5～ 0.7	7,600～ 6,800	0.004～ 0.01	9,600～ 9,100	0.004～ 0.01	5,700～ 5,100	0.0035～ 0.0075	4,900～ 4,400	0.003～ 0.006	7,600～ 6,800	0.004～ 0.01
φ0.8～ 1.4	6,800～ 6,400	0.015～ 0.02	8,800～ 8,000	0.015～ 0.02	5,100～ 4,800	0.01～ 0.015	3,100～ 2,900	0.007～ 0.01	6,800～ 6,400	0.015～ 0.02
φ1.5～ 2	4,300～ 3,200	0.02～ 0.03	5,300～ 4,000	0.03～ 0.05	3,200～ 2,400	0.02～ 0.03	2,000～ 1,500	0.02～ 0.03	4,300～ 3,200	0.03～ 0.05
φ2.1～ 3	2,700	0.03～ 0.05	3,200	0.07	2,000	0.04	1,200	0.04	2,700	0.07

被削材 Work Materials	チタン合金 Titan Alloy	
ドリル径 Drill Dia. (mm)	回転数 Rotation (min <sup>-1</sup> )	送り量 Feed (mm/rev)
φ0.1～ 0.2	7,400	0.0003～ 0.0007
φ0.3～ 0.4	6,600～ 6,200	0.001～ 0.002
φ0.5～ 0.7	5,900～ 5,300	0.003～ 0.006
φ0.8～ 1.4	5,300～ 5,000	0.007～ 0.01
φ1.5～ 2	3,400～ 2,500	0.02～ 0.03
φ2.1～ 3	2,000	0.04

- ▶ステップ送り量: φ0.1～φ0.4: ドリル径×10% (0.1D)  
Step Feed φ0.5～φ3.0: ドリル径×25% (0.25D)

### 備考

- 1) 細穴、特にφ1.0以下の穴あけ加工の場合には、ガイド穴（センター穴）を施した上で穴加工を行うして下さい。  
ドリル食い付き時の破損・チッピングを防ぎます。
- 2) チャッキング時のドリル振れ精度は0.003mm以下に抑えて下さい。
- 3) ご使用の機械の最高回転数が上記切削条件に達しない場合は、なるべく安定領域での高い回転数でご使用下さい。  
その場合送り量も同じ比率で下げて下さい。
- 4) ドリルφ0.5以下ご使用の場合は、上記切削条件よりもご使用のスピンドル精度が最も安定する回転数を優先させて下さい。

### Remarks:

- 1) When drilling smaller hole, especially under φ1.0mm, the guide hole (positioning by starting drill) is necessary.  
It prevents the drill breakage and initial chipping of cutting edge.
- 2) The run out with a drill in a spindle should be minimized to less than 0.003mm.
- 3) When machines can not achieve a recommended rotation speed, please set maximum speed but in stable rotation range and adjust the feed rate.
- 4) For smaller drills under φ0.5, the most stable rotation speed of actually using spindle has priority over the recommended conditions indicated in the table.

# ADS 標準ソリッドドリル

ADS Solid Drill, Standard Straight Shank

# ADSL ソリッドセミロングドリル

ADSL Semi Long Drill, Straight Shank

被削材 Work Materials	炭素鋼 Carbon steel SS S50C		合金鋼 Alloy Steel SCM SKS		調質鋼 Hardened Steel NAK SKD (HRC30~38)		鑄鉄 Cast Iron FC25		オーステナイト系 SUS304/316 Austenitic	
	ドリル径 Drill Dia. (mm)	回転数 Rotation (min <sup>-1</sup> )	送り量 Feed (mm/rev)	回転数 Rotation (min <sup>-1</sup> )	送り量 Feed (mm/rev)	回転数 Rotation (min <sup>-1</sup> )	送り量 Feed (mm/rev)	回転数 Rotation (min <sup>-1</sup> )	送り量 Feed (mm/rev)	回転数 Rotation (min <sup>-1</sup> )
φ0.3~ 0.5	12,000~ 10,000	0.005~ 0.01	10,000~ 9500	0.003~ 0.01	8,500~ 7,600	0.002~ 0.008	12,000~ 10,000	0.01~ 0.02	5,300	0.0005~ 0.001
φ0.6~ 1.0	10,000~ 9,500	0.01~ 0.02	8,000~ 6,400	0.007~ 0.015	6,400~ 4,800	0.003~ 0.01	10,000~ 9,500	0.01~ 0.04	5,300~ 4,800	0.001~ 0.005
φ1.1~ 2.0	7,200~ 6,400	0.02~ 0.06	5,800~ 3,200	0.01~ 0.02	4,400~ 3,200	0.01~ 0.015	8,700~ 7,200	0.06~ 0.15	4,300~ 3,200	0.005~ 0.02
φ2.1~ 2.9	6,100~ 4,400	0.06~ 0.08	3,000~ 2800	0.02~ 0.04	3,000~ 2,800	0.015~ 0.02	6,800~ 4,900	0.06~ 0.15	3,000~ 2,200	0.02~ 0.03
φ3.0~ 5.0	4,300~ 2,600	0.08~ 0.1	2,700~ 2,000	0.04~ 0.08	2,700~ 1,900	0.02~ 0.04	4,800~ 3,200	0.1~0.2	2,100~ 1,300	0.03~ 0.05
φ6.0~ 8.0	2,200~ 1,900	0.1~ 0.12	1,600~ 1,400	0.05~ 0.1	1,600~ 1,400	0.02~ 0.06	2,600~ 2,000	0.15~ 0.25	1,100~ 800	0.05~ 0.1
φ9.0~ 13.0	1,600~ 1,200	0.1~ 0.12	1,300~ 1,000	0.05~ 0.1	1,200~ 900	0.04~ 0.08	1,800~ 1,500	0.2~ 0.4	700~ 500	0.05~ 0.1

被削材 Work Materials	マルテンサイト・ フェライト系 SUS303/420/430 Martensitic & Ferritic		アルミ・銅合金 Aluminium Copper Alloy	
	ドリル径 Drill Dia. (mm)	回転数 Rotation (min <sup>-1</sup> )	送り量 Feed (mm/rev)	送り量 Feed (mm/rev)
φ0.3~ 0.5	8,000~ 6,300	0.0005~ 0.001	20,000~ 16,000	0.02~ 0.05
φ0.6~ 1.0	6,300~ 5,300	0.001~ 0.005	20,000~ 16,000	0.06~ 0.15
φ1.1~ 2.0	5,300~ 4,700	0.005~ 0.02	16,000~ 13,000	0.1~ 0.2
φ2.1~ 2.9	4,500~ 3,300	0.02~ 0.03	13,000~ 10,000	0.1~ 0.2
φ3.0~ 5.0	3,200~ 1,900	0.03~ 0.05	8,500~ 6,400	0.1~ 0.2
φ6.0~ 8.0	1,600~ 1,200	0.05~ 0.1	5,300~ 4,000	0.2~ 0.3
φ9.0~ 13.0	1,100~ 750	0.05~ 0.1	3,000~ 2,500	0.4~ 0.5

## 備考

- 1) 切削条件は当初上記条件表の低い値より選定し、徐々に高い値にして最適条件でご使用下さい。
- 2) 工具の突き出し長さはできるだけ短くしてご使用下さい。
- 3) ご使用の機械の最高回転数が上記切削条件に達しない場合は、なるべく安定領域での高い回転数で使用し、送り速度を調整して下さい。

## Remarks:

- 1) It is generally recommended to start with the lowest speed and feed shown in the table.  
They may be gradually increased to higher points to obtain the fittest condition.
- 2) Overhanging length of the tool from the chuck should be minimized.
- 3) When machines can not achieve a recommended rotation speed, use the maximum speed but in stable rotation range and adjust the feed rate.

# ADL ソリッド ロングドリル

ADL Long Drill, Straight Shank

# ADLL ソリッドスーパーロングドリル

ADLL Super Long Drill, Straight Shank

被削材 Work Materials	炭素鋼 Carbon steel SS S50C		合金鋼 Alloy Steel SCM SKS		調質鋼 Hardened Steel NAK SKD (HRC30~38)		鋳鉄 Cast Iron FC25		ステンレス鋼 Stainless Steel SUS303, 420	
	ドリル径 Drill Dia. (mm)	回転数 Rotation (min <sup>-1</sup> )	送り量 Feed (mm/rev)	回転数 Rotation (min <sup>-1</sup> )	送り量 Feed (mm/rev)	回転数 Rotation (min <sup>-1</sup> )	送り量 Feed (mm/rev)	回転数 Rotation (min <sup>-1</sup> )	送り量 Feed (mm/rev)	回転数 Rotation (min <sup>-1</sup> )
φ0.3~ 0.5	10,000	0.004	9,000	0.002	7,000	0.0015	10,000	0.005	4,000	0.001
φ0.6~ 1.0	10,000~ 9,500	0.01~ 0.02	8,000~ 6,400	0.007~ 0.015	6,400~ 4,800	0.003~ 0.01	10,000~ 9,500	0.01~ 0.04	4,800~ 3,800	0.001~ 0.005
φ1.1~ 2.0	7,200~ 6,400	0.02~ 0.06	5,800~ 3,200	0.01~ 0.02	4,400~ 3,200	0.01~ 0.015	8,700~ 7,200	0.06~ 0.15	4,300~ 3,200	0.005~ 0.02
φ2.1~ 2.9	6,100~ 4,400	0.06~ 0.08	3,000~ 2800	0.02~ 0.04	3,000~ 2,800	0.015~ 0.02	6,800~ 4,900	0.06~ 0.15	3,000~ 2,200	0.01~ 0.03
φ3.0~ 5.0	4,300~ 2,600	0.08~ 0.1	2,700~ 2,000	0.04~ 0.08	2,700~ 1,900	0.02~ 0.04	4,800~ 3,200	0.1~ 0.2	2,100~ 1,900	0.03~ 0.05
φ6.0~ 8.0	2,200~ 1,900	0.1~ 0.12	1,600~ 1,400	0.05~ 0.1	1,600~ 1,400	0.02~ 0.06	2,600~ 2,000	0.15~ 0.25	1,600~ 1,200	0.05~ 0.1
φ9.0~ 13.0	1,600~ 1,200	0.1~ 0.12	1,300~ 1,000	0.05~ 0.1	1,200~ 900	0.04~ 0.08	1,800~ 1,500	0.2~ 0.3	1,100~ 750	0.05~ 0.1

被削材 Work Materials	アルミ・銅合金 Aluminium Copper Alloy	
	ドリル径 Drill Dia. (mm)	送り量 Feed (mm/rev)
φ0.3~ 0.5	10,000	0.01~ 0.02
φ0.6~ 1.0	20,000~ 12,000	0.06~ 0.15
φ1.1~ 2.0	16,000~ 13,000	0.1~ 0.2
φ2.1~ 2.9	13,000~ 10,000	0.1~ 0.2
φ3.0~ 5.0	8,500~ 6,400	0.2~ 0.25
φ6.0~ 8.0	5,300~ 4,000	0.2~ 0.3
φ9.0~ 13.0	3,000~ 2,500	0.3~ 0.4

**備考**

- 1) 切削条件は当初上記条件表の低い値より選定し、徐々に高い値にして最適条件でご使用下さい。
- 2) この切削条件はドリルの突出し長さが、刃長の1.1倍を基準としています。この基準以上の突き出し量で使用する場合は回転速度、送り速度を下げてください。
- 3) ロングドリルご使用の場合は、切削条件は当初低い値より設定し、徐々に高い値にして最適加工条件でご使用下さい。
- 4) ロングドリルご使用の場合は、より安定した精度の良い穴あけ加工を可能にするためブッシュの使用をお勧めします。

**Remarks:**

- 1) It is generally recommended to start with the lowest speed and feed shown in the table. They may be gradually increased to higher points to obtain the fittest condition.
- 2) This drilling conditions are based on the tool extension length being 1.1 times the flute length. When the extension length from the chuck is longer than 1.1 times of flute length, please reduce the above value for speed and feed appropriately.
- 3) When a long drill used, you are requested to start with the lowest speed and feed shown in the table, They may be gradually increased to higher points to obtain the fittest condition.
- 4) It is recommended to use the drill bush for stable and preciser drilling holes.

# V-ADS コーティング付き標準ドリル

## Solid Coated Drill, Standard Straight Shank

被削材 Work Materials	炭素鋼 Carbon steel SS S50C		合金鋼 Alloy Steel SCM SKS		調質鋼 Hardened Steel NAK SKD (HRC30-38)		鋳鉄 Cast Iron FC25		オーステナイト系 SUS304/316 Austenitic	
	ドリル径 Drill Dia. (mm)	回転数 Rotation (min <sup>-1</sup> )	送り量 Feed (mm/rev)	回転数 Rotation (min <sup>-1</sup> )	送り量 Feed (mm/rev)	回転数 Rotation (min <sup>-1</sup> )	送り量 Feed (mm/rev)	回転数 Rotation (min <sup>-1</sup> )	送り量 Feed (mm/rev)	回転数 Rotation (min <sup>-1</sup> )
φ0.3~ 0.5	14,000~ 12,500	0.006~ 0.012	14,000~ 12,500	0.004~ 0.012	11,000~ 9,500	0.002~ 0.008	14,000~ 12,500	0.012~ 0.025	6,600	0.0005~ 0.001
φ0.6~ 1.0	11,000~ 9,500	0.012~ 0.025	10,000~ 8,000	0.008~ 0.02	8,000~ 6,400	0.003~ 0.01	12,000	0.012~ 0.05	6,600~ 6,200	0.001~ 0.005
φ1.1~ 2.0	8,700~ 8,000	0.025~ 0.07	7,200~ 6,400	0.012~ 0.025	5,800~ 4,000	0.01~ 0.015	11,000~ 8,000	0.07~ 0.2	5,600~ 4,200	0.005~ 0.02
φ2.1~ 2.9	7,600~ 5,500	0.07~ 0.1	6,000~ 4,400	0.025~ 0.05	4,000~ 3,300	0.015~ 0.02	7,600~ 5,500	0.07~ 0.2	3,900~ 2,900	0.02~ 0.03
φ3.0~ 6.0	5,300~ 3,200	0.1~ 0.12	4,200~ 2,500	0.05~ 0.1	3,200~ 1,900	0.02~ 0.04	5,300~ 3,900	0.12~ 0.25	2,800~ 1,700	0.03~ 0.05

被削材 Work Materials	マルテンサイト・ フェライト系 SUS303/420/430 Martensitic & Ferritic	
	ドリル径 Drill Dia. (mm)	送り量 Feed (mm/rev)
φ0.3~ 0.5	10,000~ 8,000	0.0005~ 0.001
φ0.6~ 1.0	8,000~ 6,900	0.001~ 0.005
φ1.1~ 2.0	6,900~ 6,200	0.005~ 0.02
φ2.1~ 2.9	5,900~ 4,300	0.02~ 0.03
φ3.0~ 6.0	4,200~ 2,500	0.03~ 0.05

### 備考

- 1) 切削条件は当初上記条件表の低い値より選定し、徐々に高い値にして最適条件でご使用下さい。
- 2) 工具の突き出し長さはできるだけ短くしてご使用下さい。
- 3) ご使用の機械の最高回転数が上記切削条件に達しない場合は、なるべく安定領域での高い回転数で使用し、送り速度を調整して下さい。

### Remarks:

- 1) It is generally recommended to start with the lowest speed and feed shown in the table. They may be gradually increased to higher points to obtain the fittest condition.
- 2) Overhanging length of the tool from the chuck should be minimized.
- 3) When machines can not achieve a recommended rotation speed, use the maximum speed but in stable rotation range and adjust the feed rate.

# ACD “マックスアル” アルミ用

## ACD "MAXAL" Drill for Aluminium

被削材 Work Materials	アルミ合金 Aluminium Alloy	
ドリル径 Drill Dia. (mm)	周速 Cutting Speed (m/min.)	送り量 Feed (mm/rev)
φ1.0~1.9	60~80	0.05~0.1
φ2.0~2.9	60~80	0.1~0.2
φ3.0~3.9	60~100	0.1~0.2
φ4.0~4.9	60~100	0.15~0.2
φ5.0~5.9	60~100	0.15~0.2
φ6.0~6.9	80~100	0.2~0.35
φ7.0~9.9	80~100	0.3~0.45
φ10.0~12.0	80~100	0.4~0.65

### 備考

- 1) 切削条件は当初上記条件表の低い値より選定し、徐々に高い値にして最適条件でご使用下さい。
- 2) 工具の突き出し長さはできるだけ短くしてご使用下さい。
- 3) ご使用の機械の最高回転数が上記切削条件に達しない場合は、なるべく安定領域での高い回転数で使用し、送り速度を調整して下さい。

### Remarks:

- 1) It is generally recommended to start with the lowest speed and feed shown in the table.  
They may be gradually increased to higher points to obtain the fittest condition.
- 2) Overhanging length of the tool from the chuck should be minimized.
- 3) When machines can not achieve a recommended rotation speed, use the maximum speed but in stable rotation range and adjust the feed rate.

# ASWR/ASWD スイープカットドリル

## Sweep Cut Drill

被削材 Work Materials	アルミ・銅合金 Aluminium Alloy		樹脂 Resin	
	回転数 Rotation (min <sup>-1</sup> )	送り量 Feed (mm/rev)	回転数 Rotation (min <sup>-1</sup> )	送り量 Feed (mm/rev)
φ0.1~0.25	20,000	0.001~0.003	17,000	0.001~0.003
φ0.3~0.4	20,000	0.005~0.02	17,000	0.005~0.02
φ0.5~0.7	17,000	0.01~0.03	14,500	0.01~0.03
φ0.8~0.9	15,000	0.02~0.04	12,800	0.02~0.04
φ1	12,000	0.03~0.05	10,000	0.03~0.05
φ1.5	9,000	0.03~0.05	7,700	0.03~0.05
φ2	6,500	0.03~0.05	5,500	0.03~0.05
φ3	4,200	0.03~0.05	3,500	0.05
φ4	3,200	0.05	2,900	0.05
φ5	2,500	0.05	2,200	0.05
φ6	2,200	0.05	1,900	0.05

### 備考

- 1) チャッキング時のドリル振れ精度は0.003mm以下に抑えて下さい。
- 2) ご使用の機械の最高回転数が上記切削条件に達しない場合は、なるべく安定領域での高い回転数でご使用下さい。その場合送り量も同じ比率で下げてください。
- 3) ドリルφ0.5以下ご使用の場合は、上記切削条件よりもご使用のスピンドル精度が最も安定する回転数を優先させて下さい。

### Remarks:

- 1) The run out with a drill in a spindle should be minimized to less than 0.003mm.
- 2) When machines can not achieve a recommended rotation speed, please set maximum speed but in stable rotation range and adjust the feed rate.
- 3) For smaller drills under φ0.5, the most stable rotation speed of actually using spindle has priority over the recommended conditions indicated in the table.

★送り量は基準切削条件の低い値に設定した方がより抜けバリの発生を抑制します。

**Exit burrs can be minimized by setting the lower feed rate than upper feed rate in the standard drilling conditions.**

### ▶ ステップ送り量:

φ0.1~φ0.45×10% (0.1D)  
φ0.5~φ1.0×20% (0.2D)  
φ1.0以上×25%~50%

### Step Feed

φ0.1~φ0.45×10% (0.1D)  
φ0.5~φ1.0×20% (0.2D)  
φ1.0 over x 25%~50%

# AMES-2/AES-2 2枚刃スクエアエンドミル

## AMES-2/AES-2 2-Flute Square End mill

被削材 Work Materials	炭素鋼 SS材 S50C Carbon Steel			合金鋼 SCM SK材 Alloy Steel			調質鋼 NAK Prehardened Steel		
	回転数 Speed (RPM)	側面 SideMilling (mm/min)	溝 Slotting (mm/min)	回転数 Speed (RPM)	側面 SideMilling (mm/min)	溝 Slotting (mm/min)	回転数 Speed (RPM)	側面 SideMilling (mm/min)	溝 Slotting (mm/min)
刃径 Diameter									
0.1~0.3	20,000	20~50	10~20	15,000	15~35	7~15	12,000	12~30	5~13
0.4~0.5	15,000	70~80	30~35	11,300	50~55	20~25	10,000	40~45	20~30
0.8	13,000	100	40	10,000	70	30	8,500	50	20
1	12,700	130	50	9,600	90	35	8,000	70	30
1.5	8,500	130	50	6,400	90	35	5,300	70	30
2	6,400	150	60	4,800	100	40	4,000	80	35
2.5	5,100	150	60	3,800	100	40	3,200	80	35
3	4,200	160	65	3,200	110	45	2,700	90	40
4	3,200	160	65	2,400	110	45	2,000	90	40
5	2,500	180	70	1,900	130	45	1,600	100	45
6	2,100	180	70	1,600	130	45	1,300	100	45
8	1,600	180	70	1,200	130	45	1,000	100	45
10	1,300	180	70	1,000	130	45	800	100	45
12	1,100	180	70	800	130	45	700	100	45

被削材 Work Materials	アルミ合金 Aluminium Alloy			銅合金 Copper Alloy			樹脂 Resin		
	回転数 Speed (RPM)	側面 SideMilling (mm/min)	溝 Slotting (mm/min)	回転数 Speed (RPM)	側面 SideMilling (mm/min)	溝 Slotting (mm/min)	回転数 Speed (RPM)	側面 SideMilling (mm/min)	溝 Slotting (mm/min)
刃径 Diameter									
0.1~0.3	25,000	100	40	20,000	70	30	20,000	90	40
0.4~0.5	20,000	150	60	18,000	100	40	18,000	130	50
0.8	18,000	200	60	15,000	150	70	17,000	170	75
1	17,500	250	100	14,300	190	80	15,900	210	95
1.5	11,700	250	100	9,600	190	80	10,600	210	95
2	8,800	300	120	7,200	230	100	8,000	250	120
2.5	7,000	300	120	5,700	230	100	6,400	250	120
3	5,800	330	140	4,800	250	110	5,300	280	130
4	4,400	330	140	3,600	250	110	4,000	280	130
5	3,500	360	150	2,900	270	120	3,200	300	140
6	2,900	360	150	2,400	270	120	2,700	300	140
8	2,200	360	150	1,800	270	120	2,000	300	140
10	1,800	360	150	1,400	270	120	1,600	300	140
12	1,500	360	150	1,200	270	120	1,300	300	140

AMES-2/AES-2切り込み量 Depth of cut

側面加工 Side Milling

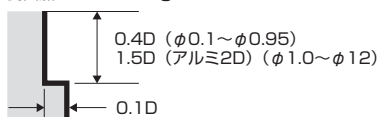

溝加工 Slotting

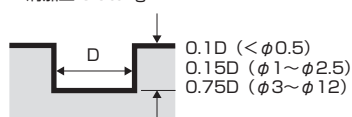



# AMEL/AEL ロング刃 スクエアエンドミル (2枚刃)

## Long Flute Square End Mill (2 flutes)

被削材 Work Materials		炭素鋼 S50C Carbon Steel				合金鋼 SCM SK材 Alloy Steel				調質鋼 NAK Prehardened Steel			
刃径 Diameter	刃長 Flute length	回転数 Speed (RPM)	送り Feed (mm/min)	切り込み幅(Ar) Cutting Width	切込深さ(Ad) Cutting Depth	回転数 Speed (RPM)	送り Feed (mm/min)	切り込み幅(Ar) Cutting Width	切込深さ(Ad) Cutting Depth	回転数 Speed (RPM)	送り Feed (mm/min)	切り込み幅(Ar) Cutting Width	切込深さ(Ad) Cutting Depth
0.1	0.7	16,000	10	0.01D	1D	13,000	7	0.01D	1D	12,000	6	0.01D	1D
0.1	1	16,000	10	0.01D	1D	13,000	7	0.01D	1D	12,000	6	0.01D	1D
0.2	1.5	14,000	10	0.05D	1D	11,200	7	0.05D	1D	10,000	6	0.05D	1D
0.2	2.0	14,000	10	0.015D	1D	11,200	7	0.015D	1D	10,000	6	0.015D	1D
0.3	2	14,000	15	0.05	2D	11,200	10	0.05	2D	10,000	8	0.05	2D
0.3	3	14,000	15	0.02	2D	11,200	10	0.02	2D	10,000	8	0.02	2D
0.5	3・4	10,500	40	0.05D	2D	8,400	30	0.05D	2D	6,700	25	0.05D	2D
0.5	5	10,500	40	0.025D	2D	8,400	30	0.025D	2D	6,700	25	0.025D	2D
0.8	5・7	9,100	50	0.05D	2D	7,300	35	0.05D	2D	5,800	25	0.05D	2D
0.8	10	9,100	50	0.025D	2D	7,300	35	0.025D	2D	5,800	25	0.025D	2D
1.0	5・6	9,500	70	0.05D	2D	7,600	45	0.05D	2D	5,700	35	0.05D	2D
1.0	7.5	9,500	70	0.05D	2D	7,600	45	0.05D	2D	5,700	35	0.05D	2D
1.0	10	9,500	70	0.025D	2D	7,600	45	0.025D	2D	5,700	35	0.025D	2D
1.0	12	9,500	70	0.025D	2D	7,600	45	0.025D	2D	5,700	35	0.025D	2D
1.2	7.5・10	8,000	70	0.05D	2D	6,400	45	0.05D	2D	5,700	35	0.05D	2D
1.2	12	8,000	70	0.03D	2D	6,400	45	0.03D	2D	5,700	35	0.03D	2D
1.5	10・15	6,500	70	0.05D	2D	5,200	45	0.05D	2D	3,800	35	0.05D	2D
1.5	18	6,500	70	0.025D	2D	5,200	45	0.025D	2D	3,800	35	0.025D	2D
1.5	20	6,500	70	0.025D	2D	5,200	45	0.025D	2D	3,800	35	0.025D	2D
2.0	10・12・15	5,000	90	0.05D	3D	4,000	55	0.05D	3D	2,900	40	0.05D	3D
2.0	20	5,000	90	0.05D	3D	4,000	55	0.05D	3D	2,900	40	0.05D	3D
2.5	15・20・25	4,000	90	0.05D	3D	3,200	60	0.05D	3D	2,300	40	0.05D	3D
3.0	20・25.30	3,200	90	0.05D	3D	2,600	70	0.05D	3D	1,900	45	0.05D	3D

被削材 Work Materials		アルミ合金 Aluminium Alloy				銅合金 Copper Alloy				樹脂 Resin			
刃径 Diameter	刃長 Flute length	回転数 Speed (RPM)	送り Feed (mm/min)	切り込み幅(Ar) Cutting Width	切込深さ(Ad) Cutting Depth	回転数 Speed (RPM)	送り Feed (mm/min)	切り込み幅(Ar) Cutting Width	切込深さ(Ad) Cutting Depth	回転数 Speed (RPM)	送り Feed (mm/min)	切り込み幅(Ar) Cutting Width	切込深さ(Ad) Cutting Depth
0.1	0.7	21,000	50	0.01D	1D	18,000	35	0.01D	1D	18,000	35	0.01D	1D
0.1	1	21,000	50	0.01D	1D	18,000	35	0.01D	1D	18,000	35	0.01D	1D
0.2	1.5	21,000	50	0.05D	1D	18,000	35	0.05D	1D	18,000	35	0.05D	1D
0.2	2.0	21,000	50	0.015D	1D	18,000	35	0.015D	1D	18,000	35	0.015D	1D
0.3	2	21,000	50	0.05	2D	18,000	50	0.05	2D	18,000	50	0.05	2D
0.3	3	21,000	50	0.02	2D	18,000	50	0.02	2D	18,000	50	0.02	2D
0.5	3・4	19,000	70	0.05D	2D	16,000	50	0.05D	2D	16,000	50	0.05D	2D
0.5	5	19,000	70	0.025D	2D	16,000	50	0.025D	2D	16,000	50	0.025D	2D
0.8	5・7	16,000	100	0.05D	2D	14,000	75	0.05D	2D	14,000	75	0.05D	2D
0.8	10	16,000	100	0.025D	2D	14,000	75	0.025D	2D	14,000	75	0.025D	2D
1.0	5・6	13,000	130	0.05D	2D	11,000	80	0.05D	2D	11,000	80	0.05D	2D
1.0	7.5	13,000	130	0.05D	2D	11,000	80	0.05D	2D	11,000	80	0.05D	2D
1.0	10	13,000	130	0.025D	2D	11,000	80	0.025D	2D	11,000	80	0.025D	2D
1.0	12	13,000	130	0.025D	2D	11,000	80	0.025D	2D	11,000	80	0.025D	2D
1.2	7.5・10	11,000	130	0.05D	2D	9,500	80	0.05D	2D	9,500	80	0.05D	2D
1.2	12	11,000	130	0.03D	2D	9,500	80	0.03D	2D	9,500	80	0.03D	2D
1.5	10・15	8,500	150	0.05D	2D	7,500	110	0.05D	2D	7,500	110	0.05D	2D
1.5	18	8,500	150	0.025D	2D	7,500	110	0.025D	2D	7,500	110	0.025D	2D
1.5	20	8,500	150	0.025D	2D	7,500	110	0.025D	2D	7,500	110	0.025D	2D
2.0	10・12・15	6,300	180	0.05D	3D	5,500	130	0.05D	3D	5,500	130	0.05D	3D
2.0	20	6,300	180	0.05D	3D	5,500	130	0.05D	3D	5,500	130	0.05D	3D
2.5	15・20・25	5,100	180	0.05D	3D	4,500	130	0.05D	3D	4,500	130	0.05D	3D
3.0	20・25.30	4,200	200	0.05D	3D	3,700	150	0.05D	3D	3,700	150	0.05D	3D

# AES-4 4枚刃スクエアエンドミル

## AES-4 4-Flute Square End mill

被削材 Work Materials	炭素鋼 SS材 S50C Carbon Steel			合金鋼 SCM SK材 Alloy Steel			調質鋼 NAK Prehardened Steel		
	回転数 Speed (RPM)	側面 SideMilling (mm/min)	溝 Slotting (mm/min)	回転数 Speed (RPM)	側面 SideMilling (mm/min)	溝 Slotting (mm/min)	回転数 Speed (RPM)	側面 SideMilling (mm/min)	溝 Slotting (mm/min)
刃径 Diameter									
1	12,700	200	80	9,600	130	55	8,000	110	45
1.5	8,500	200	80	6,400	130	55	5,300	110	45
2	6,400	230	90	4,800	150	60	4,000	120	50
2.5	5,100	230	90	3,800	150	60	3,200	120	50
3	4,200	240	100	3,200	160	70	2,700	140	60
4	3,200	240	100	2,400	160	70	2,000	140	60
5	2,500	240	110	1,900	190	70	1,600	150	70
6	2,100	240	110	1,600	190	70	1,300	150	70
8	1,600	240	110	1,200	190	70	1,000	150	70
10	1,300	240	110	1,000	190	70	800	150	70
12	1,100	240	110	800	190	70	700	150	70

被削材 Work Materials	アルミ合金 Aluminium Alloy			銅合金 Copper Alloy			樹脂 Resin		
	回転数 Speed (RPM)	側面 SideMilling (mm/min)	溝 Slotting (mm/min)	回転数 Speed (RPM)	側面 SideMilling (mm/min)	溝 Slotting (mm/min)	回転数 Speed (RPM)	側面 SideMilling (mm/min)	溝 Slotting (mm/min)
刃径 Diameter									
1	17,500	380	240	14,300	290	120	15,900	320	140
1.5	11,700	380	240	9,600	290	120	10,600	320	140
2	8,800	450	290	7,200	340	150	8,000	380	180
2.5	7,000	450	290	5,700	340	150	6,400	380	180
3	5,800	500	320	4,800	380	170	5,300	420	200
4	4,400	500	320	3,600	380	170	4,000	420	200
5	3,500	540	350	2,900	410	180	3,200	450	210
6	2,900	540	350	2,400	410	180	2,700	450	210
8	2,200	540	350	1,800	410	180	2,000	450	210
10	1,800	540	350	1,400	410	180	1,600	450	210
12	1,500	540	350	1,200	410	180	1,300	450	210

◀ AMEL/AEL 側面加工 Side Milling

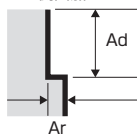

AES-4切り込み量 溝加工 Slotting

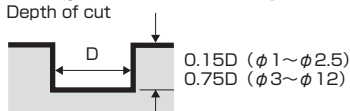

側面加工 Side Milling

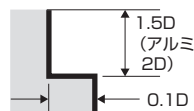

# AMBES-2/ABES-2 2枚刃ボールエンドミル

## AMBES-2/ABES-2 2-Flute Ball End Mill

被削材 Work Materials		炭素鋼 SS材 50C Carbon Steel		合金鋼 SCM SKD Alloy Steel		調質鋼 NAK Hardened Steel		アルミ合金 Aluminium Alloy	
R Radius	刃径 Diameter	回転数 Speed (RPM)	送り Feed (mm/min)	回転数 Speed (RPM)	送り Feed (mm/min)	回転数 Speed (RPM)	送り Feed (mm/min)	回転数 Speed (RPM)	送り Feed (mm/min)
R0.1~R0.2	0.2~0.4	22,000	220	20,000	160	17,000	100	30,000	350
R0.3~R0.4	0.6~0.8	20,000	300	18,000	250	15,500	170	28,000	500
R0.5	1	19,000	400	16,500	330	14,300	260	25,000	600
R0.8	1.6	12,000	400	10,400	330	9,000	260	15,900	600
R1	2	9,500	400	8,300	330	7,100	260	12,700	600
R2	4	4,800	400	4,200	330	3,600	260	6,400	600
R3	6	3,100	400	2,700	330	2,300	260	4,200	600
R4	8	2,400	400	2,100	330	1,800	260	3,200	600
R5	10	1,900	400	1,700	330	1,400	260	2,500	600
R6	12	1,600	400	1,400	330	1,200	260	2,100	600
R7	14	1,400	400	1,200	330	1,100	260	1,800	600
R8	16	1,200	400	1,000	330	900	260	1,600	600
R9	18	1,000	400	900	330	800	260	1,400	600
R10	20	950	400	800	330	700	260	1,300	600

被削材 Work Materials		銅合金 Copper Alloy		樹脂 Resin	
R Radius	刃径 Diameter	回転数 Speed (RPM)	送り Feed (mm/min)	回転数 Speed (RPM)	送り Feed (mm/min)
R0.1~R0.2	0.2~0.4	26,000	300	27,000	300
R0.3~R0.4	0.6~0.8	24,000	400	25,000	400
R0.5	1	22,500	500	21,000	500
R0.8	1.6	13,900	500	14,900	500
R1	2	11,100	500	11,900	500
R2	4	5,600	500	6,000	500
R3	6	3,700	500	4,000	500
R4	8	2,800	500	3,000	500
R5	10	2,200	500	2,400	500
R6	12	1,900	500	2,000	500
R7	14	1,600	500	1,700	500
R8	16	1,400	500	1,500	500
R9	18	1,200	500	1,300	500
R10	20	1,100	500	1,200	500

## 備考

- 1) 機械、チャックは剛性のある精度の高いものをご使用下さい。
- 2) チャッキング時のエンドミルの振れ精度は0.01mm以下に抑えて下さい。
- 3) ご使用の機械の最高回転数が上記切削条件に達しない場合は、なるべく安定領域での高い回転数で使用し、送り速度を調整して下さい。

## Remarks:

- 1) Use a rigid and precise machine and holder.
- 2) The run out with an end mill in a spindle should be within 0.01mm.
- 3) When using low speed machines, use the maximum speed but in stable rotation range and adjust the feed rate.

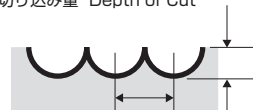
AMBES-2/ABES-2  
切り込み量 Depth of Cut0.05D (R0.1~R0.475)  
0.2D (≥R0.5)0.03D~0.05D (R0.1~R0.9)  
0.08D~0.1D (R1~R10)

# ABES-4 4枚刃ボールエンドミル

## ABES-4 4-Flute Ball End Mill

被削材 Work Materials		炭素鋼 SS材 50C Carbon Steel		合金鋼 SCM SKD Alloy Steel		調質鋼 NAK Hardened Steel		アルミ合金 Aluminium Alloy	
R Radius	刃径 Diameter	回転数 Speed (RPM)	送り Feed (mm/min)	回転数 Speed (RPM)	送り Feed (mm/min)	回転数 Speed (RPM)	送り Feed (mm/min)	回転数 Speed (RPM)	送り Feed (mm/min)
R0.5	1	19,000	400	16,500	330	14,300	260	18,000	600
R1	2	9,500	400	8,300	330	7,100	260	12,700	600
R1.5	3	6,400	400	5,300	330	4,200	260	8,500	600
R2	4	4,800	400	4,200	330	3,600	260	6,400	600
R2.5	5	3,800	400	3,200	330	2,500	260	5,100	600
R3	6	3,100	400	2,700	330	2,300	260	4,200	600
R4	8	2,400	400	2,100	330	1,800	260	3,200	600
R5	10	1,900	400	1,700	330	1,400	260	2,500	600
R6	12	1,600	400	1,400	330	1,200	260	2,100	600

被削材 Work Materials		銅合金 Copper Alloy		樹脂 Resin	
R Radius	刃径 Diameter	回転数 Speed (RPM)	送り Feed (mm/min)	回転数 Speed (RPM)	送り Feed (mm/min)
R0.5	1	15,000	500	17,000	500
R1	2	11,000	500	12,000	500
R1.5	3	7,400	500	8,000	500
R2	4	5,600	500	5,800	500
R2.5	5	4,600	500	4,800	500
R3	6	3,700	500	4,000	500
R4	8	2,800	500	3,000	500
R5	10	2,200	500	2,400	500
R6	12	1,900	500	2,000	500

### 備考

- 1) 機械、チャックは剛性のある精度の高いものをご使用下さい。
- 2) チャッキング時のエンドミルの振れ精度は0.01mm以下に抑えて下さい。
- 3) ご使用の機械の最高回転数が上記切削条件に達しない場合は、なるべく安定領域での高い回転数で使用し、送り速度を調整して下さい。

### Remarks:

- 1) Use a rigid and precise machine and holder.
- 2) The run out with an end mill in a spindle should be within 0.01mm.
- 3) When using low speed machines, use the maximum speed but in stable rotation range and adjust the feed rate.

# AERS ラジアスエンドミル (2枚刃)

## 2-Flute Radius End Mill

被削材 Work Materials	炭素鋼 S50C Carbon Steel			合金鋼 SCM SK材 Alloy Steel			調質鋼 NAK Prehardened Steel		
刃径 Diameter	回転数 Speed (RPM)	送り速度 Feed mm/min		回転数 Speed (RPM)	送り速度 Feed mm/min		回転数 Speed (RPM)	送り速度 Feed mm/min	
		側面 SideMilling	溝 Slotting		側面 SideMilling	溝 Slotting		側面 SideMilling	溝 Slotting
		1	11,400		100	40		10,200	70
1.5	7,700	100	40	6,800	70	35	5,100	65	30
2	5,800	100	40	5,100	70	35	3,800	65	30
2.5	4,600	100	40	4,100	70	35	3,000	65	30
3	3,800	120	50	3,400	95	40	2,600	75	35
4	2,900	120	50	2,600	95	40	1,900	75	35
5	2,300	140	55	2,000	110	45	1,500	90	40
6	1,900	140	55	1,700	110	45	1,300	90	40

被削材 Work Materials	アルミ・銅合金・樹脂 Aluminium・Copper Alloy & Resin		
刃径 Diameter	回転数 Speed (RPM)	送り速度 Feed mm/min	
		側面 SideMilling	溝 Slotting
		1	19,000
1.5	12,700	200	80
2	9,500	200	80
2.5	7,600	200	80
3	6,400	240	100
4	4,800	240	100
5	3,800	280	110
6	3,200	280	110

AERS 切り込み量 Depth of cut

側面加工 Side Milling

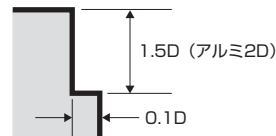

溝加工 Slotting

**備考**

- 1) 機械、チャックは剛性のある精度の高いものをご使用下さい。
- 2) チャッキング時のエンドミルの振れ精度は0.01mm以下に抑えて下さい。
- 3) ご使用の機械の最高回転数が上記切削条件に達しない場合は、なるべく安定領域での高い回転数で使用し、送り速度を調整して下さい。

**Remarks:**

- 1) Use a rigid and precise machine and holder.
- 2) The run out with an end mill in a spindle should be within 0.01mm.
- 3) When using low speed machines, use the maximum speed but in stable rotation range and adjust the feed rate.

# ACR コーナーRカッター

## 2-Flute Corner Radius Cutter

R Radius	炭素鋼 SS材 S50C Carbon Steel		合金鋼 SCM SKD Alloy Steel		調質鋼 NAK Hardened Steel		アルミ・銅合金・樹脂 Aluminium・Copper Alloy & Resin	
	回転数 Speed (RPM)	送り Feed (mm/min)	回転数 Speed (RPM)	送り Feed (mm/min)	回転数 Speed (RPM)	送り Feed (mm/min)	回転数 Speed (RPM)	送り Feed (mm/min)
R0.1~R0.25	6,400	55	5,100	45	3,800	35	10,000	100
R0.3~R0.5	5,300	55	4,200	45	3,200	35	8,800	100
R0.55~R0.75	4,200	55	3,500	45	2,800	35	7,000	100
R0.8~R1.0	3,800	55	3,200	45	2,500	35	6,300	100
R1.05~R1.25	3,400	55	2,900	45	2,400	35	5,600	100
R1.3~R1.5	3,200	55	2,700	45	2,300	35	5,300	100
R1.55~R1.75	3,000	55	2,500	45	2,100	35	5,000	100
R1.8~R2.0	2,500	55	2,100	45	1,800	35	4,200	100
R2.05~R2.25	2,300	55	2,000	45	1,700	35	3,800	100
R2.3~R2.5	2,200	55	1,900	45	1,600	35	3,700	100

### 刃部詳細図

Details of cutting edge

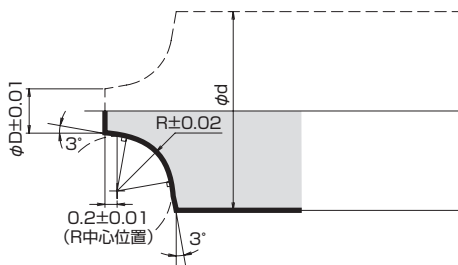

### 備考

- 1) 機械、チャックは剛性のある精度の高いものをご使用下さい。
- 2) チャッキング時のエンドミルの振れ精度は0.01mm以下に抑えて下さい。
- 3) ご使用の機械の最高回転数が上記切削条件に達しない場合は、なるべく安定領域での高い回転数で使用し、送り速度を調整して下さい。

### Remarks:

- 1) Use a rigid and precise machine and holder.
- 2) The run out with an end mill in a spindle should be within 0.01mm.
- 3) When using low speed machines, use the maximum speed but in stable rotation range and adjust the feed rate.

# ATES テーパーエンドミル/ATBES テーパーボール(2枚刃)

## ATES-2 Taper End Mill/ATBES-2 Taper Ball End Mill

被削材 Work Materials	炭素鋼 SS材 S50C Carbon Steel			合金鋼 SCM SK材 Alloy Steel			調質鋼 NAK Prehardened Steel		
	刃径 Diameter	回転数 Speed (RPM)	側面 SideMilling (mm/min)	溝 Slotting (mm/min)	回転数 Speed (RPM)	側面 SideMilling (mm/min)	溝 Slotting (mm/min)	回転数 Speed (RPM)	側面 SideMilling (mm/min)
0.1	20,000	30	20~30	15,000	20	15~20	15,000	15	10~20
0.2	20,000	50	30	15,000	40	20	15,000	30	20
0.3	18,000	70	40	13,000	50	30	13,000	40	20
0.4~0.5	15,000	80	50	11,300	55	40	10,000	45	30
0.8	13,000	100	60	10,000	70	45	8,500	50	30
1	12,700	130	75	9,600	90	50	8,000	70	45
1.5	8,500	130	75	6,400	90	50	5,300	70	45
2	6,400	150	90	4,800	100	60	4,000	80	55
2.5	5,100	150	90	3,800	100	60	3,200	80	55
3	4,200	160	100	3,200	110	70	2,700	90	60

被削材 Work Materials	アルミ合金 Aluminium Alloy			銅合金 Copper Alloy		
	刃径 Diameter	回転数 Speed (RPM)	側面 SideMilling (mm/min)	溝 Slotting (mm/min)	回転数 Speed (RPM)	側面 SideMilling (mm/min)
0.1	25,000	100	60	20,000	70	40
0.2	25,000	100	60	20,000	70	40
0.3	22,000	150	60	18,000	100	40
0.4~0.5	20,000	150	90	18,000	100	60
0.8	18,000	200	90	15,000	150	60
1	17,500	250	150	14,300	190	100
1.5	11,700	250	150	9,600	190	100
2	8,800	300	180	7,200	230	130
2.5	7,000	300	180	5,700	230	130
3	5,800	330	210	4,800	250	150

ATES/ATBES 切り込み量  
Depth of cut

側面加工 Side Milling

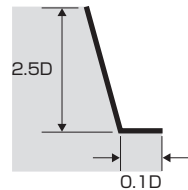

溝加工 Slotting

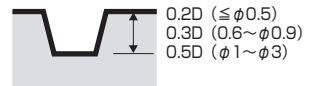

### 備考

- 1) 機械、チャックは剛性のある精度の高いものをご使用下さい。
- 2) チャッキング時のエンドミルの振れ精度は0.01mm以下に抑えて下さい。
- 3) ご使用の機械の最高回転数が上記切削条件に達しない場合は、なるべく安定領域での高い回転数で使用し、送り速度を調整して下さい。

### Remarks:

- 1) Use a rigid and precise machine and holder.
- 2) The run out with an end mill in a spindle should be within 0.01mm.
- 3) When using low speed machines, use the maximum speed but in stable rotation range and adjust the feed rate.





# 參考資料

Data

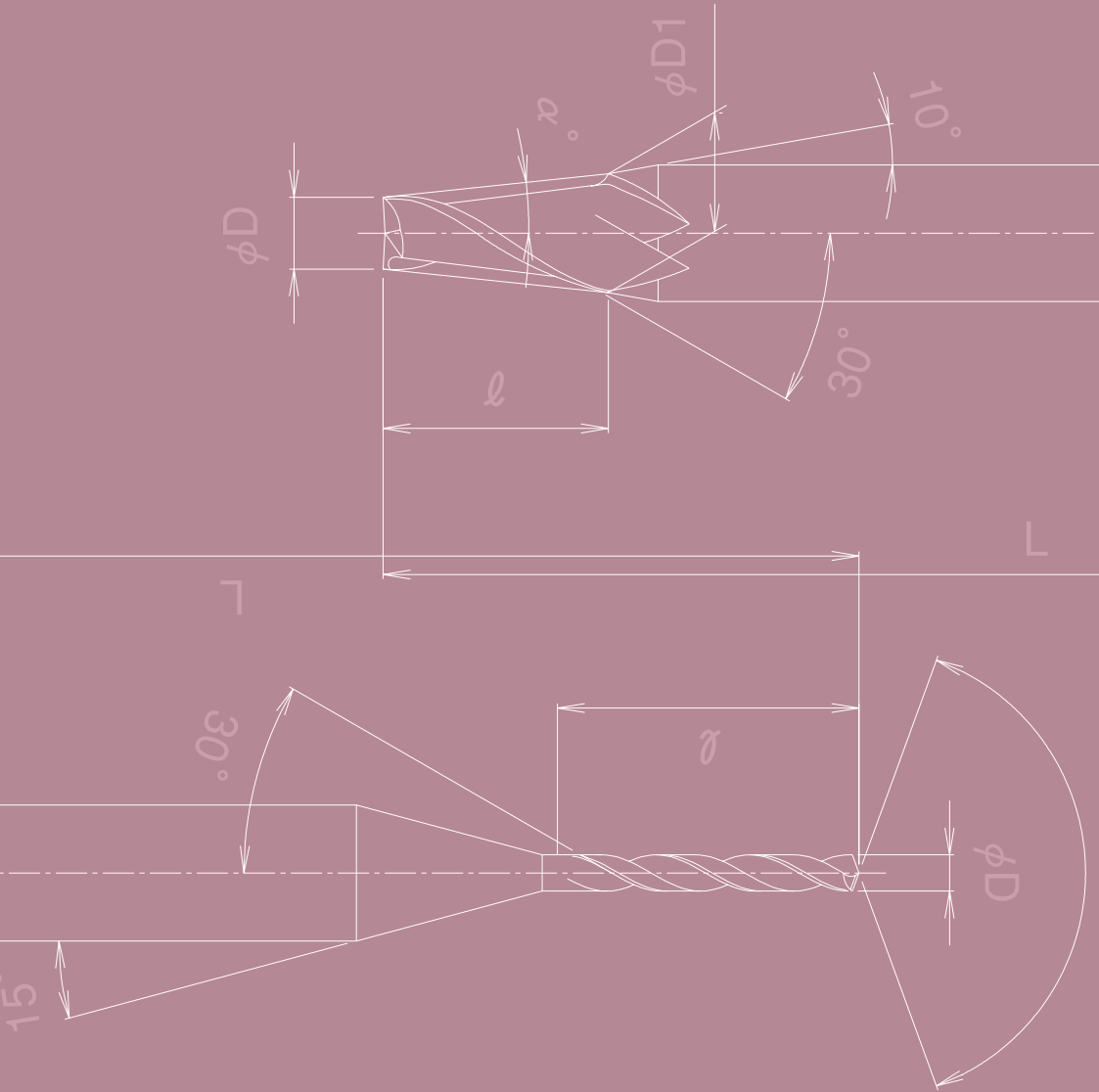

# マイクロドリル “NEO-PRO” シリーズ

Micro Drill "NEO-PRO" Series, for Steels

Feature of ADR-SV, ADRS-SV, ADRSL-SV, ADRL-SV Drill

FCSコーティング

## 特長

Feature

■ S50C、SCM、SK材などの鋼材の多孔穴加工用に開発されたドリルです。チップポケットを広く設計、高速・高送りの条件下でも切粉がスムーズに排出されます。

This micro drill has been developed for multi-hole drilling in steels, such as carbon steels, alloy steels and hardened steels. Wide chip pocket can make smooth chip evacuation under the high speed and feed drilling conditions.



■ ショート刃 (ADRS-SV) / 標準刃長 (ADR-SV) / セミロング刃 (ADRSL-SV) / ロング刃 (ADRL-SV) の4型番を標準化。加工穴深さに応じた刃長のドリルが選べます。

"NEO-PRO" series provide four different flute lengths. You can choose a proper one depend on the depth of hole.

■ 小径ドリルの切れ刃エッジを生かすため、小径専用のファインコーティングシステム(FCS)を採用。切れ味と耐摩耗性を追及したコーティングドリルです。

Thanks to the Fine Coating System especially developed for micro drills, keeping sharp edge, Sharp cutting performance and wear resistance are ideally balanced.



■ 中間サイズφ1.6mm以上は切れ刃エッジにホーニング加工を付与しました。それにより、高周速 (V)・高送りにおける切れ刃のチッピングを抑制し、より長い工具寿命を実現します。

Due to the slight-horning on over  $\phi 1.6$ mm drills, "NEO-PRO" series realizes long tool life with preventing chipping in high speed and high feed drilling condition.

## 工具寿命比較

Tool life comparison with competitors

### 他社品との寿命比較 (平均値 / 加工回数5回)

加工条件 回転数：20,000rpm 送り (F)：80mm/min.(0.004mm/re.) ステップ (Q)：0.05mm  
ドリル径： $\phi 0.3$ mm 穴深さ (t)：3mm

被削材 S50C

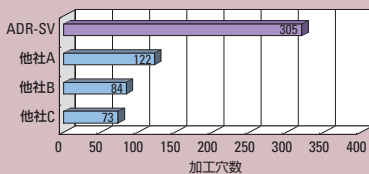

被削材 SCM440

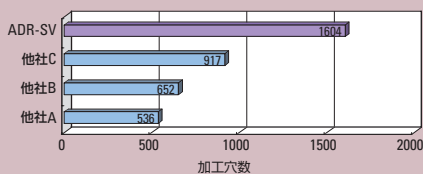

難削材用マイクロドリル Micro Drill for Hard-to-Cut Materials

**ADR-SUS ドリルの特長**

Feature of ADR-SUS &amp; ADRL-SUS Drill

**特長**

## Feature

■ ステンレス鋼などの難削材用に独自に開発した刃部形状は耐摩耗性、耐チッピング性に優れています。かつ全体設計を高剛性仕様とし、耐折損性の向上をはかっています。

ADR-SUS Drill has excellent chipping and wear resistance due to our originally developed cutting edge form for the hard-to-cut materials such as stainless steel.

■ ドリル径0.3mmからシンニング付き。スラスト方向の抵抗が削減し、ステンレス鋼加工時の発熱による加工硬化、溶着が抑制され、表面処理効果と併せ長寿命を実現します。

By decreasing thrust cutting load due to the thinning (from drill  $\varnothing 0.3\text{mm}$ ), reducing work hardening and welding caused by cutting heat in drilling stainless steel, it ensure long tool life with an effect of surface treatment.

■ 表面処理は小径専用PVDコーティング方式を採用。小径ドリルの切れ刃も均一に皮膜されています。

Thanks to PVD Coating technology especially developed for small tools, It enables uniformity of coating condition even on the cutting edge of small size drills.

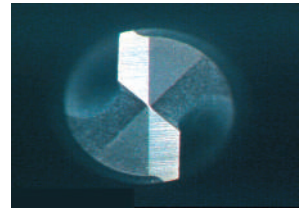
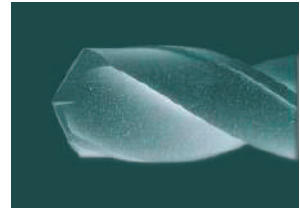
**性能**

## Performance

■ 他社ステンレス用ドリル（HSS/コーティング）との耐摩耗性比較

Comparison of wear resistance with other HSS/coated drills for stainless steel.

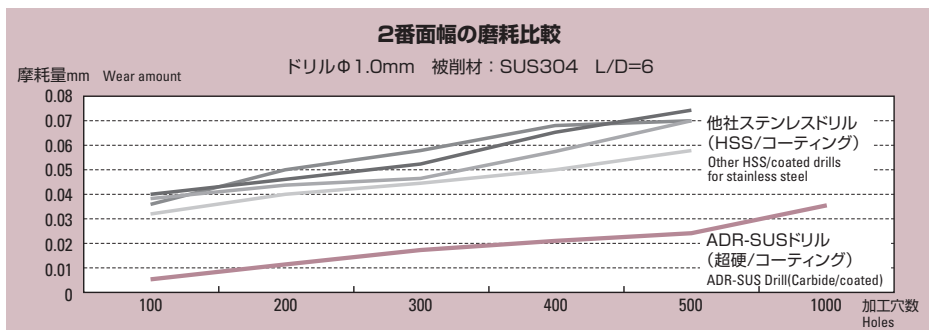

# NCポインティングドリルの加工データ

## NC Pointing Drill Data



■ 穴ピッチ精度比較 (穴径: 0.5mm 穴深さ: 10mm)  
Comparison of hole pitch accuracy <Hole  $\phi$ 0.5mm Hole depth:10mm>

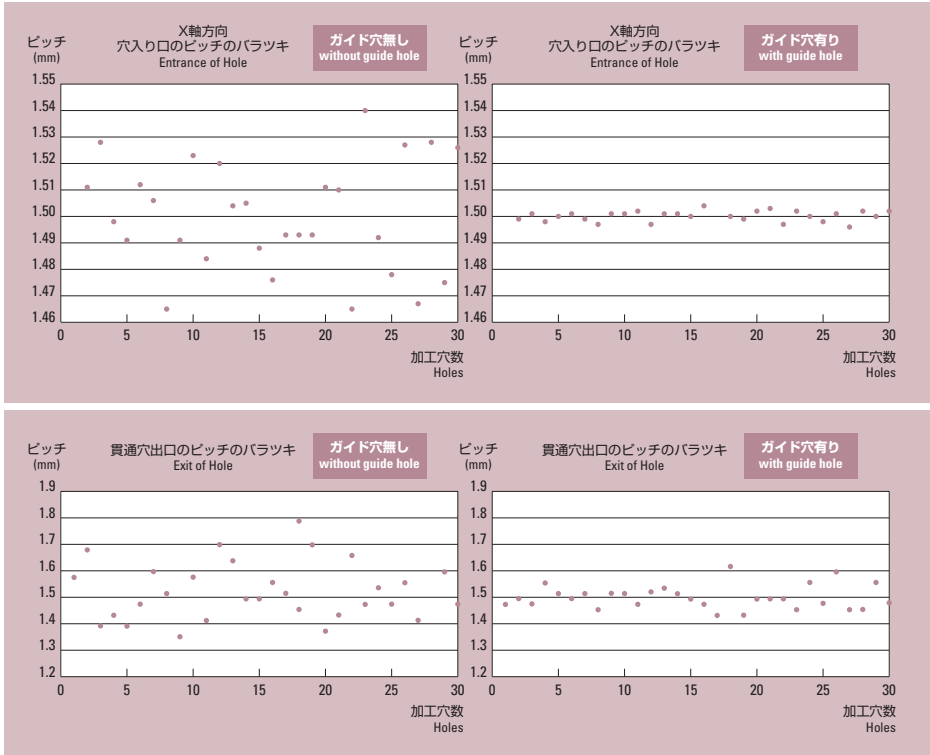

### 加工条件

### Cutting Condition

被削材	Work material	NAK55
ガイド穴用		NCポインティングドリル (ADPF30) $\phi$ 0.5
回転数	Speed	9,500rpm
送り	Feed	95mm/min
加工深さ	Drilling depth	0.5mm
穴あけ用		超硬ルーマドリルロング刃 (ADRL) $\phi$ 0.5
回転数	Speed	6,500rpm
送り	Feed	95mm/min
加工深さ	Drilling depth	10mm
ステップ	Step feed	0.05mm

# スイープカットドリルの加工データ

## Sweep Cut Drilling Data

～汎用ドリルとスイープカットの抜けバリ比較～  
 ~ Comparison of Exit Burr ~



### 事例1 Sample 1

ワーク材：ピーク（樹脂） Work Materials : Peek (Resin)

穴径：2mm Hole :  $\phi$ 2mm

加工条件：3,200rpm F=160mm/min. Cutting Condition : 3,200rpm F=160mm/min

■ 汎用ドリル  
General Purpose Drill

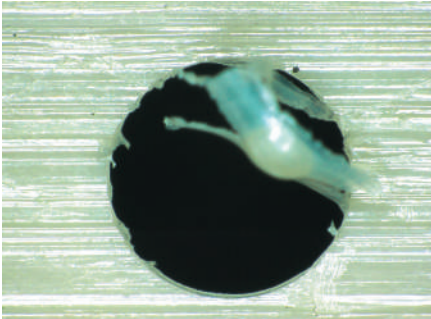

■ スイープカットドリル  
Sweep Cut Drill

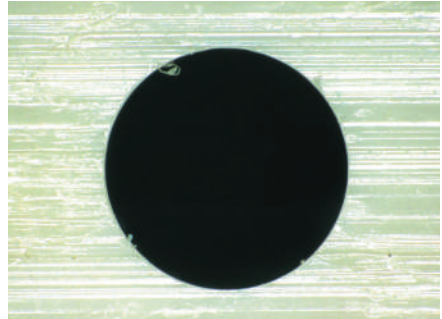

### 事例1 Sample 1

ワーク材：アルミA5052 Work Materials : Aluminium A5052

穴径：1mm Hole :  $\phi$ 1mm

加工条件：6,400rpm F=320mm/min. Cutting Condition : 6,400rpm F=320mm/min

■ 汎用ドリル  
General Purpose Drill

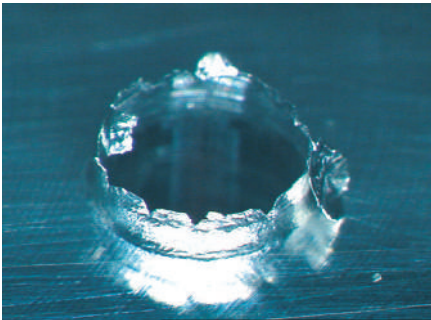

■ スイープカットドリル  
Sweep Cut Drill

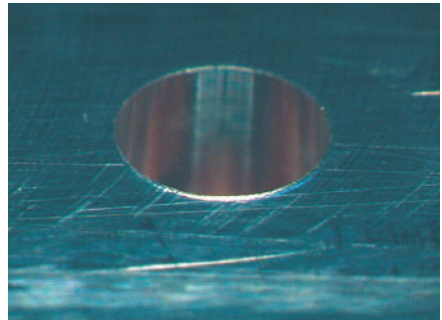

# 切削速度・回転数・送り量の求め方

Calculation for Cutting Speed, Rotation Speed and Feed rate

$$V = \frac{\pi \times D \times N}{1,000}$$

$$F = f \times N$$

V=切削速度[周速](m/min)

Cutting Speed

F=テーブル送り速度 (mm/min)

Feed/min.

$\pi = 3.14$ [円周率]

Circular Constant

D=刃径 (mm)

Tool Diameter

N=1分間当たりの回転数[RPM] ( $\text{min}^{-1}$ )

Rotation Speed per minute

f=1回転当たりの送り量 (mm/rev)

Feed rate/rev.

■ ご使用の機械の当社の最高回転数が基準切削条件達しない場合は、なるべく安定領域での高い回転数でご使用下さい。その場合送り量も同じ比率で下げて下さい。

When the maximum spindle speed can not achieve a recommended rotation speed, please set it's higher speed but in stable rotation range and adjust the feed rate.

## 小径ドリルのステップ送り量(Q)の目安

Recommended Step Feed amount (Q)

ドリル径	ステップ送り量 (mm)
$\phi 0.02 \sim \phi 0.4$	$D \times 0.1$
$\phi 0.5 \sim \phi 0.9$	$D \times 0.2$
$\phi 1 \sim \phi 3$	$D \times 0.2 \sim 0.5$

ステップ送り量(Q)=刃径(D)×係数

# 硬さ対照表

## Hardness Comparison Table

ロックウェル硬さ Cスケール	ビッカース硬さ HV	ブリネル硬さ 10mm/球・荷重 3000kg	ロックウェル硬さ Aスケール (60 Kgs)	ショア硬さ	引張り強さ 近似値
Rockwell Hardness C Scale(150Kg)	Vickers	Brinell Hardness 10mm/ Ball	Rockwell Hardness A Scale (60kg)	Shore Hardness	Tensile Strength
HRC	HV	HB	HRA	HS	(N/mm <sup>2</sup> )
68	940	-	85.6	97	-
67	900	-	85.5	95	-
66	865	-	84.5	92	-
65	832	-	83.9	91	-
64	800	-	83.4	88	-
63	772	-	82.8	87	-
62	746	-	82.3	85	-
61	720	-	81.8	83	-
60	697	-	81.2	81	-
59	674	-	80.7	80	-
58	653	-	80.1	78	-
57	633	-	79.6	76	-
56	613	-	79	75	-
55	595	-	78.5	74	2079
54	577	-	78	72	2010
53	560	-	77.4	71	1952
52	544	500	76.8	69	1883
51	528	487	76.3	68	1824
50	513	475	75.9	67	1755
49	498	464	75.2	66	1687
48	484	451	74.7	64	1639
47	471	442	74.1	63	1578
46	458	432	73.6	62	1530
45	446	421	73.1	60	1481
44	434	409	72.5	58	1432
43	423	400	72	57	1383
42	412	390	71.5	56	1334
41	402	381	70.9	55	1294
40	392	371	70.4	54	1245
39	382	362	69.9	52	1216
38	372	353	69.4	51	1177
37	363	344	68.9	50	1157
36	354	336	68.4	49	1118
35	345	327	67.9	48	1079
34	336	319	67.4	47	1059
33	327	311	66.8	46	1030
32	318	301	66.3	44	1000
31	310	294	65.8	43	981
30	302	286	65.3	42	952
29	294	279	64.7	41	932
28	285	271	64.3	41	912
27	279	264	63.8	40	883
26	272	258	63.3	38	863
25	266	253	62.8	38	843
24	260	247	62.4	37	824
23	254	243	62	36	804
22	248	237	61.5	35	785
21	243	231	61	35	775
20	238	226	60.5	34	755
(18)	230	219	-	33	736
(16)	222	212	-	32	706
(14)	213	203	-	31	677
(12)	204	194	-	29	647
(10)	196	187	-	28	618
(8)	188	179	-	27	598
(6)	180	171	-	26	579
(4)	173	165	-	25	549
(2)	166	158	-	24	530
0	160	152	-	24	520

# 超硬・超微粒子合金材種記号一覧表

使用分類記号		アライド	アサヒ工具	ダイ	デアロイ	富士ダイス	日立ツール	京セラ	マコトロイ	三菱	瑞穂工業		
大分類	記号	マテリアル	製作所	ジェット	工業				工業	マテリアル			
超硬合金	P	P01		AP 01	SRN	SH 01							
		P10		AP 10	SRT	SH 05		WS10		ST10	STi 10T		
		P20		AP 20 AP 25	SRT DX30	SH 20 SH 25	T 20	EX35		ST20	STi 20		
		P30		AP 30	SR30 DX30 DX35	SH 30		EX35 EX40	PW 30	ST30			
		P40		AP 40	SR30 DX35	SH 40		EX45					
	M	M10		AM 10	UMN UM10	N 10		WA10B			RT9010		
		M20		AM 20	DX25 UM20 UMS	N 20		EX35			UTi20T		
		M30		AM 30 MX 30	DX25 UM30 UMS	N 30		EX40 EX45			UTi20T		
		M40		AM 40	UM40	N 40		EX45 WA40					
	K	K01		AH 01	KG03	H 2		WH05		FK05 FT 07	HTi05T	MX02 MF	
		K10	H 10	AH 10	KG10 KT9 CR1	H 1 GH 10	N10	WH10	KW 10	FK05 FT 07 FH10	Hti 10 RT9010	G 1	
		K20	G 20	AH 20 G 2	KG20 KT9 CR1	GH 20		WH20		FR15 FD20	HTi20T	G 2	
		K30	G 30	AH 30	KG30 LF12	GH 30						G 3	
	超微粒子合金	Z	Z01			FB10 FZ05		F08	NM08		ZZ05	MF10	MX01
			Z10	FS10		FB15, FZ15 FB20, FZ10	WF10	F10 M10	NM10 NM12	FW30	ZZ10 ZF10	MF20 UF20	G 2F
			Z20	FM10K FM20K	MA	FB15, FZ15 FB20,		F20	BRM20		ZF10	TF15 UF30	G 6F
Z30			FM25K		FZ20 FB20			NM25					



	日本 ハードメタル	日本 タングステン	日本特殊 合金	サン・アロイ 工業	サンドビック	セコ・ツールズ ジャパン	住友電気 工業	東邦金属	東芝 タンガロイ	ゲーリング・ ジャパン	ケナメタル	セラメタル
		SN 03										
	TP 10	SN 10	PN 10	PA 10	S1P		ST 10P	T 10	TX10S	DP100	K2885	S1X7
	TP 20	SN 20 SN 25 FL37S	PN 20 PN 30	PA 20	SMA	S10M	ST 20E	T 20	TX20 TX25	DP250	K125M	S3X7 SMS SMX
		SN 30	PN30 PN35 WN30 P3B	PA 30	SMA 30	S25M	A 30N A 30 ST30E	T 30	TX 30 UX 30	DP300D DP300	KMF	S4X7
		SN 40	PN 40	PA 40	S6	S60M	ST 40E	T 40	TX 40	DP450	PVA	S6X7
		UN 10		MA 10	H 10A	890 HX		U 10	TU10	DM150	K68 KMI K313	GS0
	NM 25 M 25K	UN 20		MA 20 UA 20	H 13A	883 S10M S25M	U 2	U 20	TU20		K8735 KMF	GS2 SMS SMX
	M27TS	UN 30	MN 30	MA 30	H 10F	S60M	A 30N A 30	U 30	UX30		PVA	
		UN 40	MN 40	MA 40			A 40	U 40	TU40			
	TK 05	HN 05	KN 01 KN 05	KA 05	H1P		H 2 H 1	H 03 H 05	TH03		K68 K313	H05X HC03
	TK 8 TK 10	HN 10 G 1	KN 05 KN 10	KA 10	H1P H10 HM		EH 10 EH510	H 10 G 1	G1F TH10 H10T	DK100	KMI K8735	H1X HC10
	TK 15 TM 5E	G 2	KN 10 KN20	KA 20	H 13A	883 890 HX	G 10E EH 20 EH520	G 2 G 21	G2F G2 KS20	DK120	KMF	H15X H20X HC20
		G 3	KN 30	KA 30			G 3	G 3 G 23	G3			HC30
	TF8K TF9		ZN01 ZN10				F0		F MD08F	DK050F		MG06
	TUZ8	FN10 FN20	ZN10 ZN15 ZN104			890	F1 AFU		M MD10	DK120F		K10-S MG12 MG15 MG18
	NF15 TUZ20K	FN30	ZN15 ZN105	FD25		883 890	AF0 AF1	MG25	MD15 EM10 MD20	DK250F		K15-S K20S MG20
		FN40				883	1A CC	MG30	UM	DK460UF		MG30

# ATOMブランド製品群

ATOM brand Cutting Tools

標準品ドリル  
Standard Drills



標準品エンドミル  
Standard End Mills



特殊工具 (受注生産品)  
Special Tools made upon request



## 安全上の注意

Attention on Safty



- 切れ刃を素手で触るとけがの危険があります。  
切れ刃には素手で触らないで下さい。
  - 工具をケースから取り出す際には、工具の飛び出しや、刃先が素手に直接触れないように注意して下さい。
  - 工具が破損して飛散することがありますので工具使用中は保護メガネや安全カバーを使用して下さい。
  - 加工前に必ず工具及び加工物の寸法を確認して下さい。
  - 工具はホルダーにしっかり固定し、振れを抑えて下さい。
  - 当カタログの推奨加工条件は目安としてご利用下さい。  
実際には加工物形状や使用機械に合わせて調整する必要があります。
  - 不水溶性切削油を使用する時は、加工時に発生する火花や破損で引火、火災の危険があります。防火対策を必ず行って下さい。
- 
- Touching sharp cutting edge with bare hand can cause injury.  
Never touch the cutting edge.
  - When removing tools from cases, be careful of getting-out of tools and don't touch directly the cutting edge.
  - Be sure to wear eye protection and use safety covers, as tools may chatter if broken.
  - Please check dimentions of tools and work materials before starting operation.
  - The tool should be firmly attached to the holder to prevent shaking.
  - Recommended cutting conditions shown in this catalog should be used as a general guide line. It is necessary to adjust conditions according to the dimentions of work and actually using machine.
  - Using a non-water-cutting fluid could lead to fires due to sparks generated during processing or heat caused by breakage Ensure that you take proper fire-prevention measures.

※本カタログに掲載されている製品の仕様は改良のため予告なく変更する場合があります。あらかじめご了承下さい。  
For improvement of tools, specification stated on this catalogue may be changed without advance notice.



本社工場 〒174-0052 東京都板橋区蓮沼町8番6号  
TEL 03-3966-7606 (代) FAX 03-3966-7600

角田工場 〒981-1518 宮城県角田市稲置字舩内16番地  
TEL 0224-65-2321 FAX 0224-65-2322

URL: <http://www.atom21.co.jp>

**SAITO SEISAKUSHO CO., LTD.**

8-6, Hasunuma-cho, Itabashi-ku, Tokyo 174-0052, Japan  
Tel. 81-3-3966-7606 Fax. 81-3-3966-7600

本カタログに掲載されている製品の仕様は改良のため予告なく変更する場合があります。あらかじめご了承ください。  
For improvement of tools, specification stated on this catalogue may be changed without advance notice.