

# GAETANO CAPORALI

PDF INTERATTIVO. FARE CLICK SU START PER ACCEDERE ALL'INDICE.

INTERACTIVE PDF. CLICK START TO GO TO THE INDEX.

**START**



**SAFEWAY**

## MORSE VISES

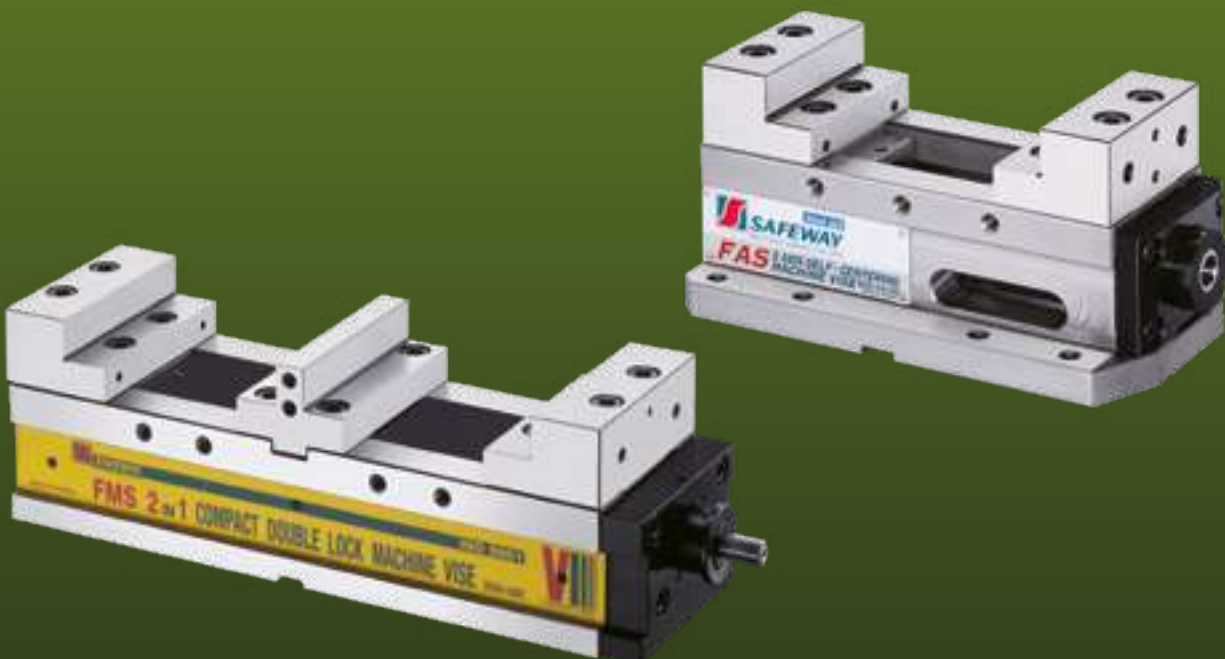

**INDEX**

PDF INTERATTIVO. FARE CLICK SULL'ARGOMENTO PER ACCEDERE DIRETTAMENTE ALLA PAGINA.  
INTERACTIVE PDF. CLICK ON A BOX TO GO DIRECTLY TO THE PAGE.

**MORSE IN GHISA**  
*CAST IRON VISES*

|  |                           |  |                           |   |                           |
|--|---------------------------|--|---------------------------|---|---------------------------|
|  |                           |  |                           |   |                           |
| <b>VCV</b>   |                           | <b>VQV</b>   |                           | <b>VDAV</b>   |                           |
| <b>STANDARD</b><br>BLOCCAGGIO A LEVA<br>CLAMPING LEVER |                           | <b>POWER LOCK</b><br>CON MOLTIPLICATORE DI FORZA MECCANICO<br>MULTIPLIER OF CLAMPING FORCE |                           | <b>DOUBLE</b><br>DOPPIO SERRAGGIO CON BLOCCAGGIO A LEVA<br>DOUBLE LOCK - CLAMPING LEVER |                           |
| LARGHEZZA - WIDTH                                      | APERTURA MAX - MAX SPREAD | LARGHEZZA - WIDTH  | APERTURA MAX - MAX SPREAD | LARGHEZZA - WIDTH   | APERTURA MAX - MAX SPREAD |
| 100  | 213                       | 100  | 213                       | 100   | 95 x2                     |
| 130  | 315                       | 130  | 315                       | 130   | 145 x2                    |
| 160  | 370                       | 160  | 370                       | 160   | 170 x2                    |
| 200  | 426                       | 200  | 426                       | 200   | 195 x2                    |
| <b>PAG. 1</b>  |                           | <b>PAG. 2</b>  |                           | <b>PAG. 3</b>   |                           |



**MORSE IN GHISA PER CENTRI DI LAVORO A 5 ASSI**  
*CAST IRON VISES FOR 5 AXIS CENTERS*



|  |                           |  |                           |   |                           |
|--|---------------------------|--|---------------------------|---|---------------------------|
|  |                           |  |                           |   |                           |
| <b>FAS-C</b>   |                           | <b>FAS-Q</b>   |                           | <b>FAS-B</b>  |                           |
| <b>STANDARD</b><br>BLOCCAGGIO A LEVA<br>CLAMPING LEVER |                           | <b>POWER LOCK</b><br>CON MOLTIPLICATORE DI FORZA MECCANICO<br>MULTIPLIER OF CLAMPING FORCE |                           | <b>CENTER</b><br>AUTOCENTRANTI CON BLOCCAGGIO A LEVA<br>SELF CENTERING - CLAMPING LEVER |                           |
| LARGHEZZA - WIDTH                                      | APERTURA MAX - MAX SPREAD | LARGHEZZA - WIDTH  | APERTURA MAX - MAX SPREAD | LARGHEZZA - WIDTH   | APERTURA MAX - MAX SPREAD |
| 100  | 145                       | 100  | 145                       | 100   | 145                       |
| <b>PAG. 4</b>  |                           | <b>PAG. 5</b>  |                           | <b>PAG. 6</b>   |                           |

**RICAMBI E ACCESSORI**  
*SPARE PARTS AND ACCESSORIES*

|   |                               |  |
|---|-------------------------------|--|
|   |                               |  |
| <b>MA - MB - MC - MD - ME - MF - MG</b> | <b>PJ - RJ - SJ - CJ - FJ</b> | <b>KA</b>                                      |
| GANASCE<br>JAWS                         | PIASTRE<br>PLATES             | CHIAVETTE DI POSIZIONAMENTO<br>STEP GUIDE KEYS |
| <b>PAG. 7-8</b>                         | <b>PAG. 9-10</b>              | <b>PAG. 11</b>                                 |

**TOLLERANZE COSTRUTTIVE**  
*MANUFACTURING TOLERANCES*

|   |  |
|---|--|
|   |  |
| <b>ACCOPPIAMENTO CHIAVETTA / GANASCIA FISSA</b><br><i>DISTANCE FROM GUIDE KEY</i> | <b>ALTEZZA DELLA SLITTA</b><br><i>HEIGHT</i>         |
|   |  |
| <b>ANGOLO DI CHIUSURA</b><br><i>CLAMPING ANGLE</i>                                | <b>TOLLERANZA DELLA PLANARITÀ</b><br><i>PARALLEL</i> |

**CARATTERISTICHE**  
*FEATURES*

- |   |  |
|---|--|
| <ul style="list-style-type: none"> <li>- morse in ghisa sferoidale GGG60</li> <li>- 60Kg/mm<sup>2</sup> o 8000psi di resistenza alla trazione</li> <li>- massima capacità di apertura e compattezza</li> <li>- piano di appoggio del pezzo temprato in HRC45: resistente all'usura e mantiene la precisione a lungo</li> <li>- ganasce temprate in HRC52÷55 e rettificate</li> <li>- chiusura a vite madre chiocciola</li> <li>- spinta obliqua (<b>Lock Down</b>) sulla ganascia mobile</li> </ul> | <ul style="list-style-type: none"> <li>- rigid material-ductile iron FCD60 JIS (equal to GGG60)</li> <li>- 60kg/mm<sup>2</sup> or 8000psi tensile strenght</li> <li>- max. opening capacity and compact in total lenght</li> <li>- vise bed hardened to HRC45 maintains accuracy for long time</li> <li>- jaws are hardened HRC52÷55 with grinding</li> <li>- clamping by lead nut screw</li> <li>- slanting push (<b>Lock Down</b>) on the movable jaw</li> </ul> |
|---|--|

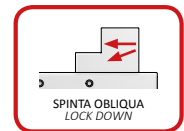

**GANASCE REVERSIBILI**  
*DOUBLE JAWS*

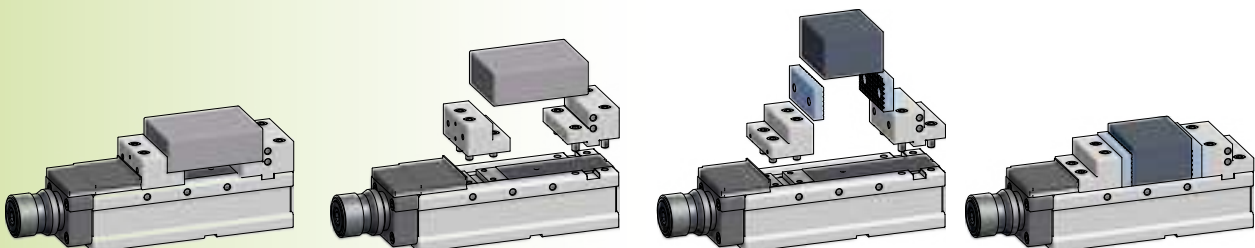
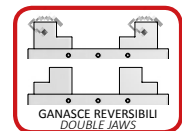
- Le morse vengono fornite con le ganasce con scalino montate. Sono disponibili diverse ganasce di ricambio.
- Le ganasce montate possono essere girate per utilizzare la superficie su cui è possibile montare le piastre.
- Vises are supplied with step jaws mounted. Other jaws are available.
- Jaws can be turned so the bigger surface can be used and the plates can be mounted.

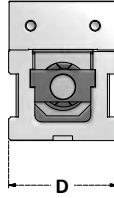
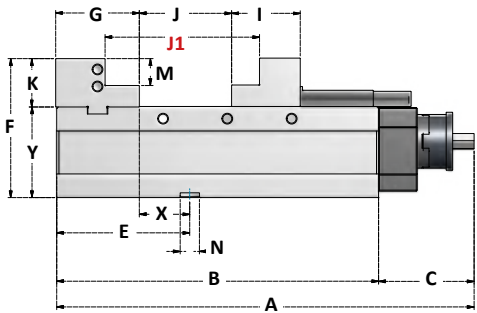

**MORSE IN GHISA**
*CAST IRON VISES*

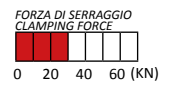
| Articolo           | J1         | A   | B   | C  | D   | E   | F   | G   | I  | J   | K  | M  | N  | X  | Y   |
|--------------------|------------|-----|-----|----|-----|-----|-----|-----|----|-----|----|----|----|----|-----|
| <b>VCV-100V-SJ</b> | <b>213</b> | 398 | 300 | 98 | 101 | 124 | 130 | 78  | 64 | 155 | 45 | 25 | 18 | 45 | 85  |
| <b>VCV-130V-SJ</b> | <b>315</b> | 508 | 410 | 98 | 131 | 149 | 147 | 83  | 74 | 230 | 52 | 30 | 18 | 65 | 95  |
| <b>VCV-160V-SJ</b> | <b>370</b> | 573 | 475 | 98 | 161 | 152 | 160 | 86  | 86 | 300 | 55 | 30 | 18 | 65 | 105 |
| <b>VCV-200V-SJ</b> | <b>426</b> | 653 | 555 | 98 | 201 | 194 | 170 | 100 | 97 | 350 | 60 | 30 | 18 | 92 | 110 |



**ALTRE LUNGHEZZE A RICHIESTA**  
*OTHER LENGTHS ON REQUEST*

**MORSE DI PRECISIONE FISSE**

- bloccaggio a leva
- fornite con le ganasce MC e MD montate
- la vite è protetta da paratrucioli

**PRECISION VISES**

- clamping lever
- supplied with MC and MD jaws
- screw protected by chip cover

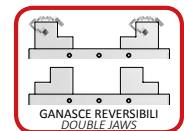
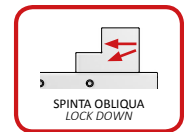
**ACCESSORI COMPRESI**
**ACCESSORIES INCLUDED**

Ganasce con scalino  
Step jaws



Chiave per il serraggio  
Clamping handle



2 chiavette di posizionamento con viti  
2 step guide keys with screw

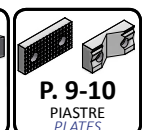
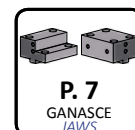

4 staffe di bloccaggio  
4 locking blocks

**SCHEDA TECNICA  
TECHNICAL DATA**

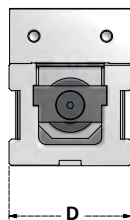
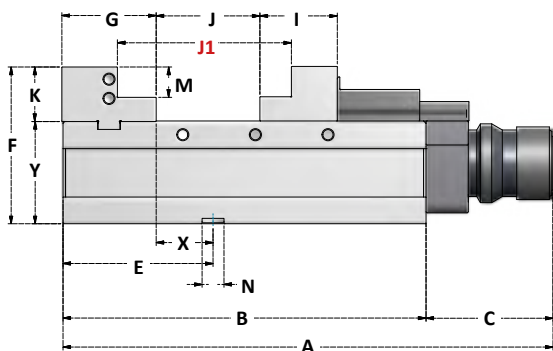
**MORSE IN GHISA POWER LOCK**
**POWER LOCK CAST IRON VISES**

| Articolo    | J1  | A   | B   | C   | D   | E   | F   | G   | I  | J   | K  | M  | N  | X  | Y   | Limit Pressure |
|-------------|-----|-----|-----|-----|-----|-----|-----|-----|----|-----|----|----|----|----|-----|----------------|
| VQV-100V-SJ | 213 | 406 | 300 | 106 | 101 | 124 | 130 | 78  | 64 | 155 | 45 | 25 | 18 | 45 | 85  | 41KN / 4018kgf |
| VQV-130V-SJ | 315 | 516 | 410 | 106 | 131 | 149 | 147 | 83  | 74 | 250 | 52 | 30 | 18 | 65 | 95  | 45KN / 4410kgf |
| VQV-160V-SJ | 370 | 581 | 475 | 106 | 161 | 152 | 160 | 86  | 86 | 300 | 55 | 30 | 18 | 65 | 105 | 54KN / 5292kgf |
| VQV-200V-SJ | 426 | 661 | 555 | 106 | 201 | 194 | 170 | 100 | 97 | 350 | 60 | 30 | 18 | 92 | 110 | 66KN / 6468kgf |

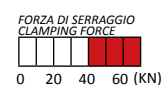

**ALTRE LUNGHEZZE A RICHIESTA**  
**OTHER LENGTHS ON REQUEST**

- MORSE DI PRECISIONE FISSE
- chiusura con moltiplicatore di spinta meccanico (**Power Lock**)
- fornite con le ganasce MC e MD montate
- la vite è protetta da paratrucoli

- **PRECISION VISES**
- *multiplier of clamping force (Power Lock)*
- *supplied with MC and MD jaws*
- *screw protected by chip cover*

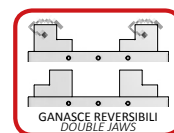
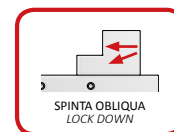
**Forza di serraggio del moltiplicatore meccanico a 5 posizioni (daN)**

*Mechanical power clamping force with 5 position (daN)*

| Articolo    | Pos. 0 | Pos. 1 | Pos. 2 | Pos. 3 | Pos. 4 |
|-------------|--------|--------|--------|--------|--------|
| VQV-100V-SJ | 392    | 980    | 1666   | 2940   | 4018   |
| VQV-130V-SJ | 392    | 980    | 1666   | 3332   | 4410   |
| VQV-160V-SJ | 490    | 1176   | 2058   | 4214   | 5992   |
| VQV-200V-SJ | 490    | 1176   | 2156   | 4704   | 6468   |

**ACCESSORI COMPRESI**
**ACCESSORIES INCLUDED**

Ganasce con scalino  
Step jaws



Chiave per il serraggio  
Clamping handle



2 chiavette di posizionamento con viti  
2 step guide keys with screw

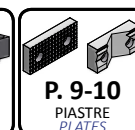
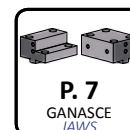

4 staffe di bloccaggio  
4 locking blocks

**SCHEDA TECNICA  
TECHNICAL DATA**

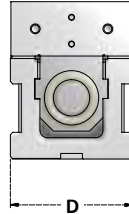
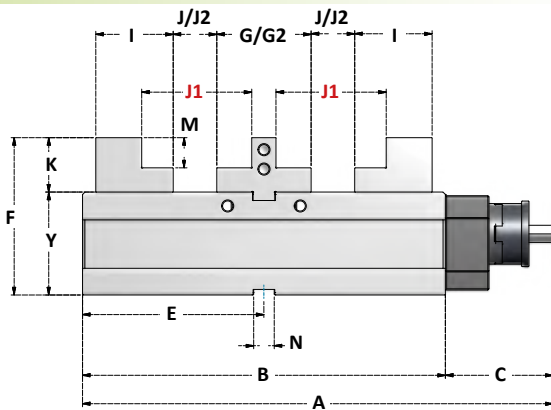
**MORSE IN GHISA DOUBLE**
*DOUBLE VISES*

| Articolo     | J1  | A   | B   | C  | D   | E     | F   | G   | G2 | I  | J   | J2  | K  | M  | N  | X    | Y   |
|--------------|-----|-----|-----|----|-----|-------|-----|-----|----|----|-----|-----|----|----|----|------|-----|
| VDAV-100V-SJ | 95  | 396 | 300 | 96 | 101 | 150   | 130 | 83  | 34 | 64 | 40  | 64  | 45 | 25 | 18 | 31,5 | 85  |
| VDAV-130V-SJ | 145 | 506 | 410 | 96 | 131 | 205   | 147 | 88  | 40 | 74 | 85  | 109 | 52 | 30 | 18 | 41,5 | 95  |
| VDAV-160V-SJ | 170 | 571 | 475 | 96 | 161 | 237,5 | 160 | 86  | 42 | 86 | 100 | 122 | 55 | 30 | 18 | 43   | 105 |
| VDAV-200V-SJ | 195 | 651 | 555 | 96 | 201 | 275,5 | 170 | 100 | 46 | 97 | 125 | 152 | 60 | 30 | 18 | 50   | 110 |

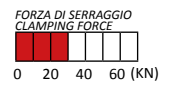

**ALTRE LUNGHEZZE A RICHIESTA**  
*OTHER LENGTHS ON REQUEST*

**MORSE DI PRECISIONE A DOPPIO SERRAGGIO**

- bloccaggio a leva
- fornite con due ganasce MD e una ganascia MG montate
- la vite è protetta da paratrucoli

**PRECISION VISES WITH DOUBLE SEATS**

- clamping lever
- supplied with two MD and one MG jaws
- screw protected by chip cover

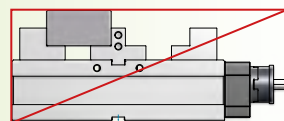
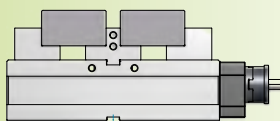
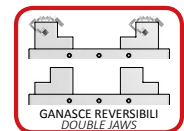
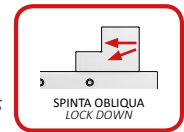

**I 2 pezzi devono essere bloccati simultaneamente.**  
**Non bloccare un solo pezzo.**  
*2 workpieces must be clamped simultaneously.*  
*Don't clamp only one workpiece.*

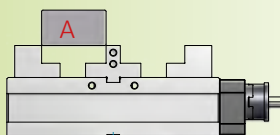

**Prima installare il pezzo A**  
*First, install A workpiece*

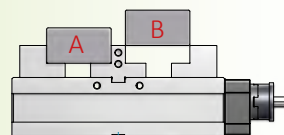

**Poi installare il pezzo B**  
*Second, install B workpiece*

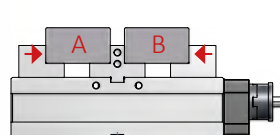

**Infine serrare insieme i pezzi A e B**  
*Finally, clamp A and B workpiece together*

**ACCESSORI COMPRESI**
**ACCESSORIES INCLUDED**

Ganasce con scalino  
Step jaws



Chiave per il serraggio  
Clamping handle



2 chiavette di posizionamento con viti  
2 step guide keys with screw

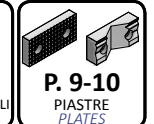
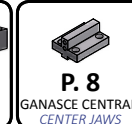
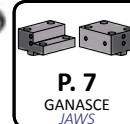

4 staffe di bloccaggio  
4 locking blocks

**SCHEMA TECNICA  
TECHNICAL DATA**

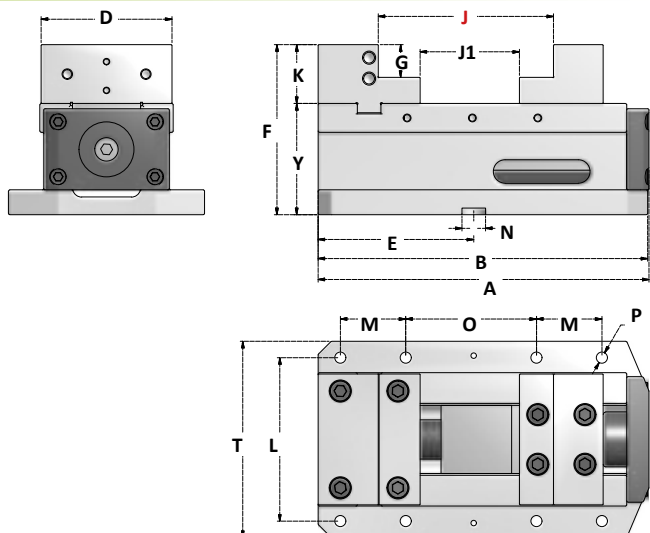
**MORSA IN GHISA PER CENTRI DI LAVORO A 5 ASSI**
*CAST IRON VISE FOR 5 AXES MACHINE CENTER*

| Articolo           | J     | A   | B   | D   | E     | F   | G  | J1   | K  | L   | M  | N  | O   | P  | T   | Y  |
|--------------------|-------|-----|-----|-----|-------|-----|----|------|----|-----|----|----|-----|----|-----|----|
| <b>FAS-100C-SJ</b> | 0-145 | 262 | 252 | 100 | 117,5 | 130 | 25 | 0-90 | 45 | 125 | 50 | 18 | 100 | M8 | 150 | 85 |

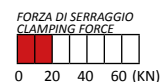
**MORSA DI PRECISIONE FISSA**

- studiata per centri di lavoro a 5 assi
- bloccaggio a leva
- fornita con le ganasce MC e MD montate

**PRECISION VISE**

- particularly suitable for 5 axis machining centers
- clamping lever
- supplied with MC and MD jaws

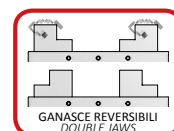
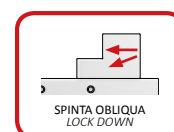

**ACCESSORI COMPRESI**
*ACCESSORIES INCLUDED*

 Ganasce con scalino  
Step jaws

 Chiave per il serraggio  
Clamping handle

 2 chiavette di posizionamento con viti  
2 step guide keys with screw

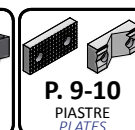
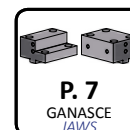
 4 staffe di bloccaggio  
4 locking blocks

**SCHEDA TECNICA  
TECHNICAL DATA**

**MORSA IN GHISA PER CENTRI DI LAVORO A 5 ASSI POWER LOCK**

CAST IRON VISE FOR 5 AXES MACHINE CENTER - POWER LOCK

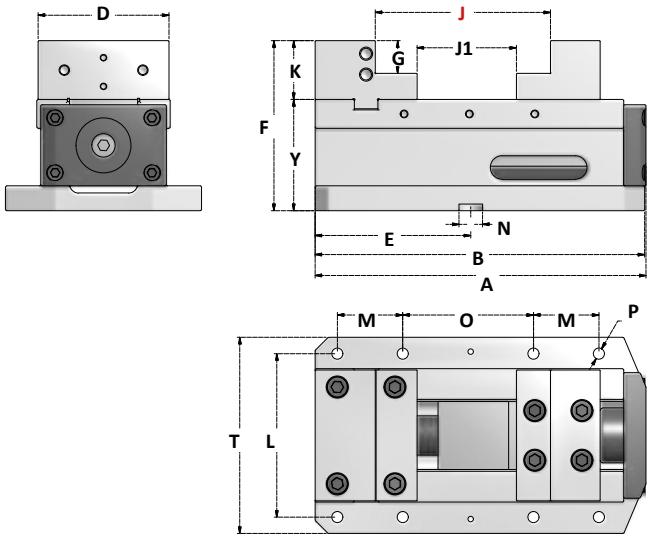

| Articolo           | J     | A   | B   | D   | E     | F   | G  | J1   | K  | L   | M  | N  | O   | P  | T   | Y  | Limit Pressure | FORZA DI SERRAGGIO<br>CLAMPING FORCE |
|--------------------|-------|-----|-----|-----|-------|-----|----|------|----|-----|----|----|-----|----|-----|----|----------------|--------------------------------------|
| <b>FAS-100Q-SJ</b> | 0-145 | 257 | 252 | 100 | 117,5 | 130 | 25 | 0-90 | 45 | 125 | 50 | 18 | 100 | M8 | 150 | 85 | 40KN / 3920kgf |                                      |

**MORSA DI PRECISIONE FISSA**

- studiata per centri di lavoro a 5 assi
- chiusura con moltiplicatore di spinta meccanico (Power Lock)
- fornita con le ganasce MC e MD montate

**PRECISION VISE**

- particularly suitable for 5 axis machining centers
- multiplier of clamping force (Power Lock)
- supplied with MC and MD jaws

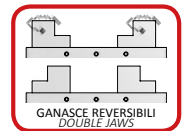
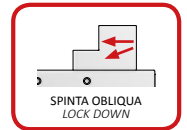

**ACCESSORI COMPRESI**
**ACCESSORIES INCLUDED**

 Ganasce con scalino  
Step jaws

 Chiave per il serraggio  
Clamping handle

 2 chiavette di posizionamento con viti  
2 step guide keys with screw

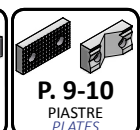
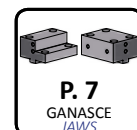
 4 staffe di bloccaggio  
4 locking blocks

**SCHEDA TECNICA  
TECHNICAL DATA**

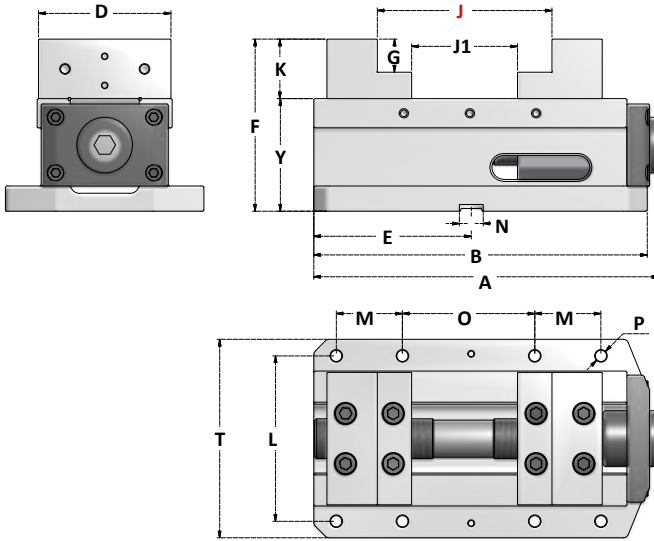

**MORSA IN GHISA PER CENTRI DI LAVORO A 5 ASSI - AUTOCENTRANTE**
*CAST IRON VISE FOR 5 AXES MACHINE CENTER - SELF CENTERING*

| Articolo           | J            | A   | B   | D   | E     | F   | G  | J1   | K  | L   | M  | N  | O   | P  | T   | Y  |
|--------------------|--------------|-----|-----|-----|-------|-----|----|------|----|-----|----|----|-----|----|-----|----|
| <b>FAS-100B-SJ</b> | <b>0-145</b> | 262 | 252 | 100 | 117,5 | 130 | 25 | 0-90 | 45 | 125 | 50 | 18 | 100 | M8 | 150 | 85 |

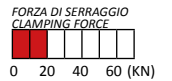
**MORSA DI PRECISIONE AUTOCENTRANTE**

- studiata per centri di lavoro a 5 assi
- bloccaggio a leva
- fornita con due ganasce MD montate

*SELF CENTERING PRECISION VISE*

- particularly suitable for 5 axis machining centers
- clamping lever
- supplied with two MD jaws

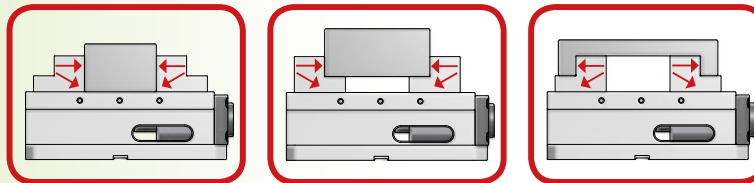
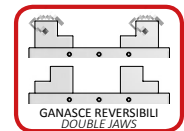
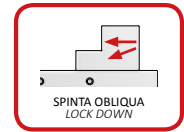
**ACCESSORI COMPRESI**
*ACCESSORIES INCLUDED*

Ganasce con scalino  
Step jaws



Chiave per il serraggio  
Clamping handle



2 chiavette di posizionamento con viti  
2 step guide keys with screw

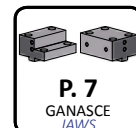

4 staffe di bloccaggio  
4 locking blocks

**SCHEDA TECNICA  
TECHNICAL DATA**

**GANASCE PER MORSE IN GHISA**
*JAWS FOR CAST IRON VISES*

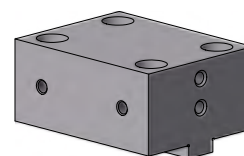
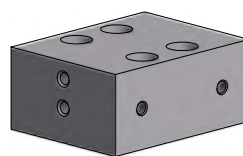
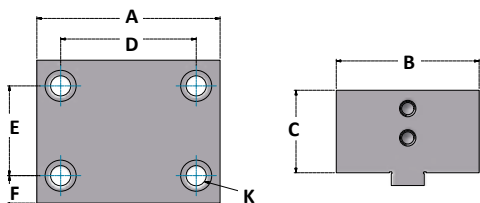
 PAGINA SUCCESSIVA  
NEXT PAGE

**GANASCE FISSE**
*STATIONARY JAWS*

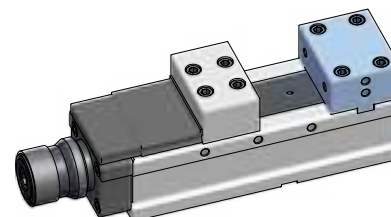
| Articolo       | A   | B   | C  | D   | E  | F    | K       |
|----------------|-----|-----|----|-----|----|------|---------|
| <b>MA-100A</b> | 100 | 78  | 45 | 74  | 44 | 19,5 | M10x50L |
| <b>MA-130A</b> | 130 | 83  | 52 | 95  | 45 | 21,5 | M12x55L |
| <b>MA-160A</b> | 160 | 86  | 55 | 124 | 50 | 18   | M14x60L |
| <b>MA-200A</b> | 200 | 100 | 60 | 150 | 62 | 19   | M16x65L |

**GANASCE MOBILI**
*MOVABLE JAWS*

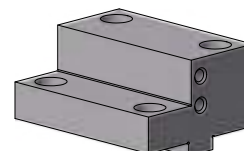
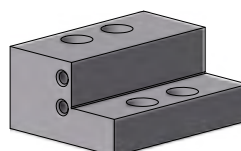
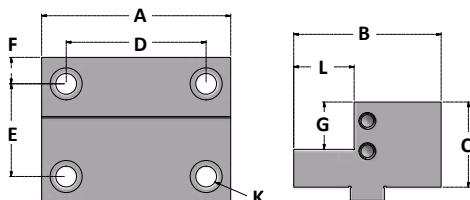
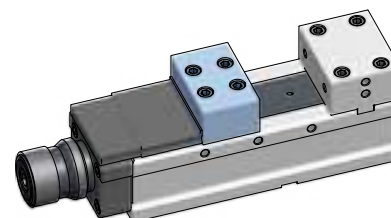
| Articolo       | A   | B  | C  | D  | E  | F    | K       |
|----------------|-----|----|----|----|----|------|---------|
| <b>MB-100A</b> | 100 | 64 | 45 | 37 | 35 | 14,5 | M10x50L |
| <b>MB-130A</b> | 130 | 74 | 52 | 45 | 42 | 16   | M12x55L |
| <b>MB-160A</b> | 160 | 86 | 55 | 60 | 50 | 18   | M14x60L |
| <b>MB-200A</b> | 200 | 97 | 60 | 74 | 59 | 19   | M16x70L |

**GANASCE FISSE CON SCALINO**
*STATIONARY STEP JAWS*

| Articolo       | A   | B   | C  | D   | E  | F    | L  | G  | K           |
|----------------|-----|-----|----|-----|----|------|----|----|-------------|
| <b>MC-100A</b> | 100 | 78  | 45 | 74  | 44 | 19,5 | 26 | 25 | M10x50L/25L |
| <b>MC-130A</b> | 130 | 83  | 52 | 95  | 45 | 21,5 | 30 | 30 | M12x55L/25L |
| <b>MC-160A</b> | 160 | 86  | 55 | 124 | 50 | 18   | 35 | 30 | M14x60L/30L |
| <b>MC-200A</b> | 200 | 100 | 60 | 150 | 62 | 19   | 38 | 30 | M16x65L/35L |

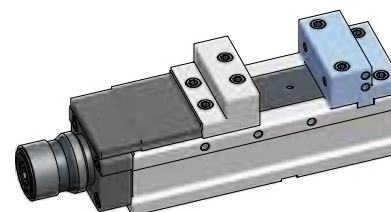

**GANASCE MOBILI CON SCALINO**
*MOVABLE STEP JAWS*

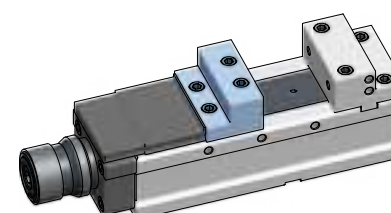
| Articolo       | A   | B  | C  | D  | E  | F    | L  | G  | K           |
|----------------|-----|----|----|----|----|------|----|----|-------------|
| <b>MD-100A</b> | 100 | 64 | 45 | 37 | 35 | 14,5 | 26 | 25 | M10x50L/25L |
| <b>MD-130A</b> | 130 | 74 | 52 | 45 | 42 | 16   | 30 | 30 | M12x55L/25L |
| <b>MD-160A</b> | 160 | 86 | 55 | 60 | 50 | 18   | 35 | 30 | M14x60L/30L |
| <b>MD-200A</b> | 200 | 97 | 60 | 74 | 59 | 19   | 38 | 30 | M16x70L/35L |

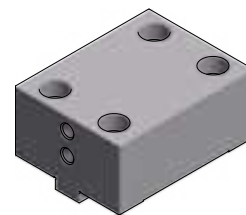
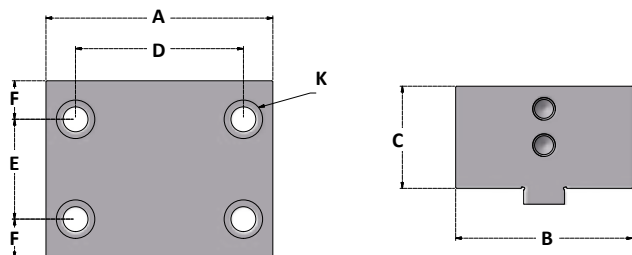

**GANASCE CENTRALI - PER MORSE VDAV**

CENTER JAWS - FOR VDAV VISES

 PAGINA PRECEDENTE  
 PREVIOUS PAGE

**GANASCE FISSE CENTRALI**

STATIONARY CENTER JAWS

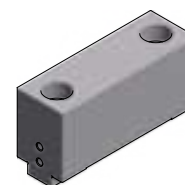
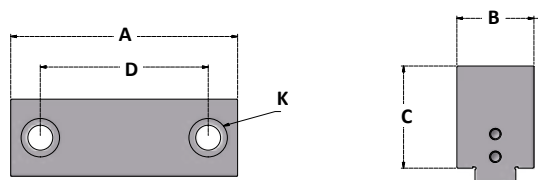
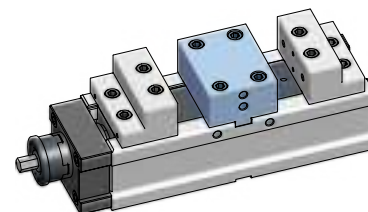
| Articolo       | A   | B   | C  | D   | E  | F    | K       |
|----------------|-----|-----|----|-----|----|------|---------|
| <b>ME-100A</b> | 100 | 124 | 45 | 74  | 44 | 19,5 | M10x50L |
| <b>ME-130A</b> | 130 | 100 | 52 | 95  | 45 | 21,5 | M12x55L |
| <b>ME-160A</b> | 160 | 86  | 55 | 124 | 50 | 18   | M14x60L |
| <b>ME-200A</b> | 200 | 83  | 60 | 150 | 62 | 19   | M16x65L |

**GANASCE FISSE CENTRALI**

STATIONARY CENTER JAWS

| Articolo       | A   | B  | C  | D   | K       |
|----------------|-----|----|----|-----|---------|
| <b>MF-100A</b> | 100 | 34 | 45 | 74  | M10x50L |
| <b>MF-130A</b> | 130 | 40 | 52 | 95  | M12x55L |
| <b>MF-160A</b> | 160 | 42 | 55 | 124 | M14x60L |
| <b>MF-200A</b> | 200 | 46 | 60 | 150 | M16x65L |

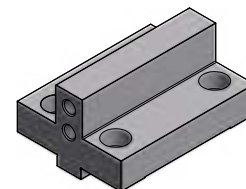
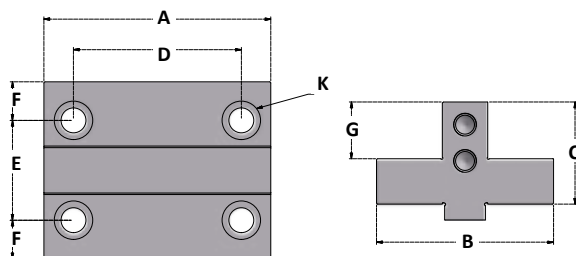
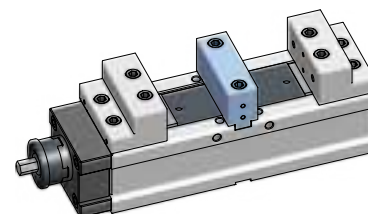

**GANASCE FISSE CENTRALI CON SCALINI**

STATIONARY CENTER STEP JAWS

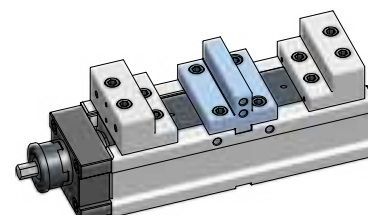
| Articolo       | A   | B   | C  | D   | E  | F    | G  | K       |
|----------------|-----|-----|----|-----|----|------|----|---------|
| <b>MG-100A</b> | 100 | 70  | 45 | 74  | 44 | 13   | 25 | M10x50L |
| <b>MG-130A</b> | 130 | 83  | 52 | 95  | 45 | 21,5 | 30 | M12x55L |
| <b>MG-160A</b> | 160 | 86  | 55 | 124 | 50 | 18   | 30 | M14x60L |
| <b>MG-200A</b> | 200 | 100 | 60 | 150 | 62 | 19   | 30 | M16x65L |

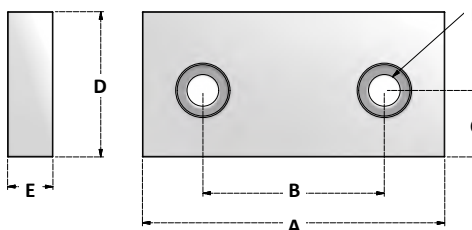
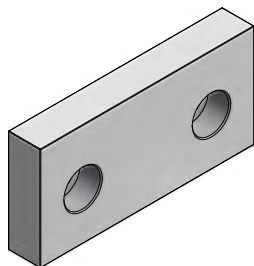

**PIASTRE PER MORSE IN GHISA**
*JAW PLATES FOR CAST IRON VISES*

 PAGINA SUCCESSIVA  
NEXT PAGE

**COPPIE DI PIASTRE LISCE**
*PAIR OF SMOOTH JAW PLATES*

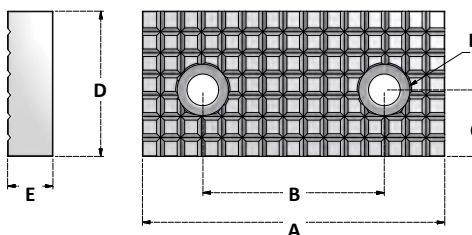
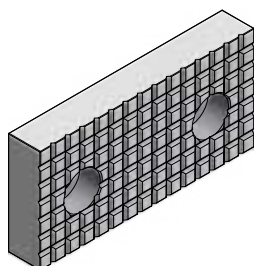
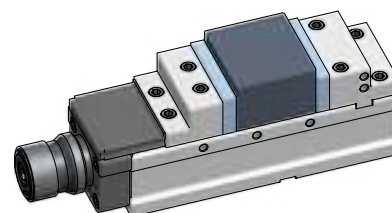
| Articolo       | A   | B   | C  | D  | E  | F       |
|----------------|-----|-----|----|----|----|---------|
| <b>PJ-100V</b> | 100 | 60  | 22 | 48 | 15 | M10x20L |
| <b>PJ-130V</b> | 130 | 90  | 25 | 55 | 15 | M10x20L |
| <b>PJ-160V</b> | 160 | 90  | 25 | 58 | 15 | M10x20L |
| <b>PJ-200V</b> | 200 | 120 | 28 | 63 | 18 | M12x25L |

**COPPIE DI PIASTRE ZIGRINATE**
*PAIR OF SERRATED JAW PLATES*

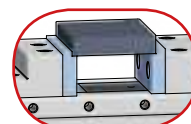
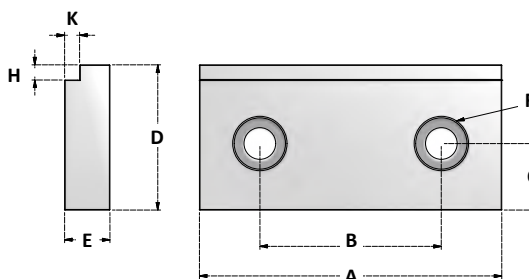
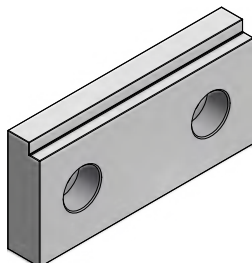
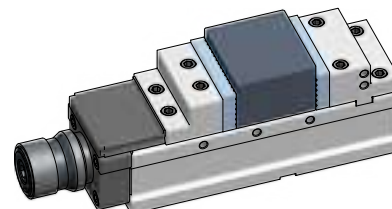
| Articolo       | A   | B   | C  | D  | E  | F       |
|----------------|-----|-----|----|----|----|---------|
| <b>RJ-100V</b> | 100 | 60  | 22 | 48 | 15 | M10x20L |
| <b>RJ-130V</b> | 130 | 90  | 25 | 55 | 15 | M10x20L |
| <b>RJ-160V</b> | 160 | 90  | 25 | 58 | 15 | M10x20L |
| <b>RJ-200V</b> | 200 | 120 | 28 | 63 | 18 | M12x25L |

**COPPIE DI PIASTRE CON SCALINO DI 5mm**
*PAIR OF JAW PLATES WITH 5mm*

| Articolo       | A   | B   | C  | D  | E  | F       | H | K |
|----------------|-----|-----|----|----|----|---------|---|---|
| <b>SJ-100V</b> | 100 | 60  | 22 | 48 | 15 | M10x20L | 5 | 5 |
| <b>SJ-130V</b> | 130 | 90  | 25 | 55 | 15 | M10x20L | 5 | 5 |
| <b>SJ-160V</b> | 160 | 90  | 25 | 58 | 15 | M10x20L | 5 | 5 |
| <b>SJ-200V</b> | 200 | 120 | 28 | 63 | 18 | M12x25L | 5 | 5 |

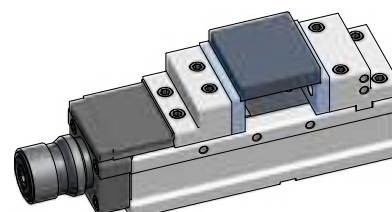

**PIASTRE PER MORSE IN GHISA**
*JAW PLATES FOR CAST IRON VISES*

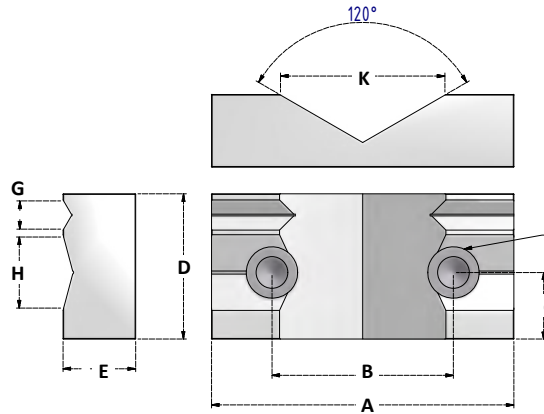
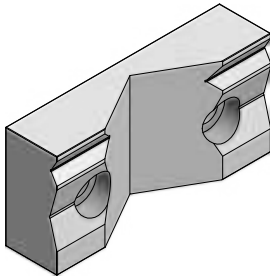
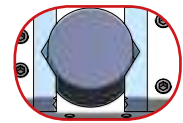
 PAGINA PRECEDENTE  
PREVIOUS PAGE

**VENDUTA SINGOLARMENTE**  
*SUPPLIED ONE PIECE*

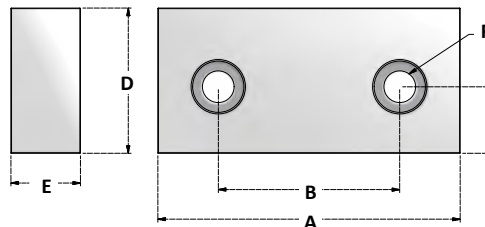
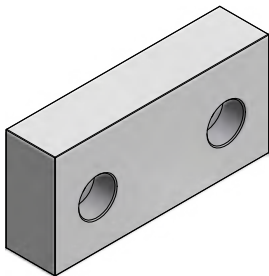
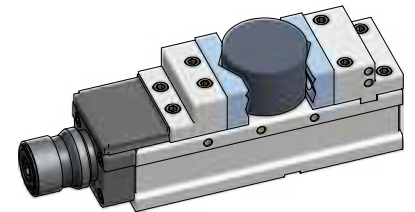
**PIASTRA PER IL BLOCCAGGIO DI PEZZI TONDI O SOTTILI**
*SPECIAL APPLICATION PLATE FOR CLAMPING OF ROUND PIECES*

| Articolo       | A   | B   | C  | D  | E  | F       | G  | H  | L  | K   |
|----------------|-----|-----|----|----|----|---------|----|----|----|-----|
| <b>CJ-100V</b> | 100 | 60  | 22 | 48 | 24 | M10x16L | /  | 25 | 55 | 94  |
| <b>CJ-130V</b> | 130 | 90  | 25 | 55 | 24 | M10x16L | 12 | 25 | 55 | 120 |
| <b>CJ-160V</b> | 160 | 90  | 25 | 58 | 30 | M10x16L | 12 | 25 | 55 | 120 |
| <b>CJ-200V</b> | 200 | 120 | 28 | 63 | 36 | M12x16L | 12 | 30 | 70 | 120 |

**COPIE DI PIASTRE LAVORABILI PER LA REALIZZAZIONE DI FORME SPECIALI**
*PAIR OF BLANK JAW PLATES FOR SPECIAL SHAPE NEEDS*

| Articolo       | A   | B   | C  | D   | E  | F       |
|----------------|-----|-----|----|-----|----|---------|
| <b>FJ-1001</b> | 100 | 60  | 22 | 48  | 15 | M10x20L |
| <b>FJ-1002</b> | 100 | 60  | 22 | 63  | 21 | M10x25L |
| <b>FJ-1003</b> | 100 | 60  | 22 | 73  | 23 | M10x30L |
| <b>FJ-1301</b> | 130 | 90  | 25 | 55  | 15 | M10x20L |
| <b>FJ-1302</b> | 130 | 90  | 25 | 73  | 23 | M10x25L |
| <b>FJ-1303</b> | 130 | 90  | 25 | 103 | 30 | M10x35L |
| <b>FJ-1601</b> | 160 | 90  | 25 | 58  | 15 | M10x20L |
| <b>FJ-1602</b> | 160 | 90  | 25 | 73  | 23 | M10x25L |
| <b>FJ-1603</b> | 160 | 90  | 25 | 103 | 30 | M10x35L |
| <b>FJ-2001</b> | 200 | 120 | 28 | 63  | 18 | M12x25L |
| <b>FJ-2002</b> | 200 | 120 | 28 | 103 | 30 | M12x35L |
| <b>FJ-2003</b> | 200 | 120 | 28 | 123 | 36 | M12x45L |

**NON TEMPRATE**  
**NON RETTIFICATE**
*NOT HARDENED*  
*AND GRINDED*

# CHIAVETTE DI POSIZIONAMENTO

## STEP GUIDE KEY

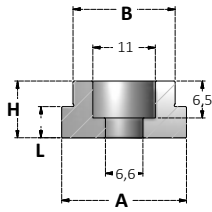

Fig.1

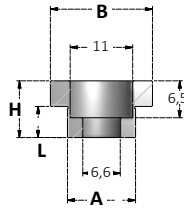

Fig.2

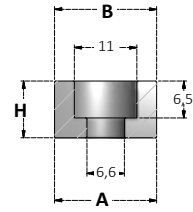
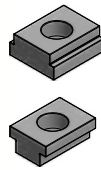

Fig.3

| Articolo         | A  | B  | H  | L   | Fig |
|------------------|----|----|----|-----|-----|
| <b>KA16x12</b>   | 16 | 12 | 10 | 5,5 | 1   |
| <b>KA16x14</b>   | 16 | 14 | 10 | 5,5 | 1   |
| <b>KA16x18</b>   | 16 | 18 | 10 | 5,5 | 2   |
| <b>KA16x18.B</b> | 16 | 18 | 10 | 6,2 | 2   |
| <b>KA16x20</b>   | 16 | 20 | 10 | 5,5 | 2   |
| <b>KA16x22</b>   | 16 | 22 | 10 | 5,5 | 2   |



**VENDUTE A COPPIE**  
*SUPPLIED IN PAIRS*

| Articolo       | A  | B  | H  | L   | Fig |
|----------------|----|----|----|-----|-----|
| <b>KA18x12</b> | 18 | 12 | 10 | 5,5 | 1   |
| <b>KA18x14</b> | 18 | 14 | 10 | 5,5 | 1   |
| <b>KA18x16</b> | 18 | 16 | 10 | 5,5 | 1   |
| <b>KA18x20</b> | 18 | 20 | 10 | 5,5 | 2   |
| <b>KA18x22</b> | 18 | 22 | 10 | 5,5 | 2   |

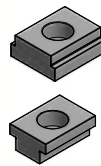

| Articolo       | A  | B  | H  | L | Fig |
|----------------|----|----|----|---|-----|
| <b>KA12x12</b> | 12 | 12 | 8  | / | 3   |
| <b>KA14x14</b> | 14 | 14 | 10 | / | 3   |
| <b>KA16x16</b> | 16 | 16 | 10 | / | 3   |
| <b>KA18x18</b> | 18 | 18 | 10 | / | 3   |
| <b>KA20x20</b> | 20 | 20 | 10 | / | 3   |
| <b>KA22x22</b> | 22 | 22 | 12 | / | 3   |



**IL PRODUTTORE**

La **Safeway** Corporation costruisce dal 1985 morse di alta precisione e tavole rotanti verticali ed orizzontali. Nata dall'intraprendenza di un progettista di macchine utensile, vince 2 edizioni del Taiwan Excellence Award con le tavole girevoli della serie SHV e con le morse a serraggio meccanico con moltiplicatore di potenza.

Dal 2004 produce la gamma di morse VCV, VQV, VHV, con le quali vince nuovamente il premio di eccellenza nel 2010.

Dal 2012 costruisce la serie FAS 5-axis in 3 versioni per un totale di 18 modelli:

FAS-100Q (moltiplicatore di forza Power Lock), FAS-100C [serraggio meccanico], FAS-100B [autocentrante].

**THE PRODUCER**

**Safeway** Corporation produces high-precision vises and vertical and horizontal rotary tables since 1985.

The company won 2 editions of the Taiwan Excellence Award for rotary tables of the SHV series and for mechanical clamping vises with power force multiplier.

Since 2004 it has been producing the VCV, VQV, VHV vises, that wins again the excellence award in 2010.

Since 2012, it has been building the FAS 5-axis series in 3 versions for a total of 18 models:

FAS-100Q (Power Lock force multiplier), FAS-100C [mechanical tightening], FAS-100B [self-centering].



## GANASCE PER APPLICAZIONI SPECIALI A RICHIESTA JAWS FOR SPECIAL WORK ARE ON REQUEST



- Ganasce smussate e ridotte. Offrono una elevata accessibilità al pezzo.
- Ganasce statiche o basculanti con gripper intercambiabili per il serraggio di pezzi con superficie irregolare o tonda.
- Gripper intercambiabili per il serraggio di varie tipologie di pezzi.
- Special jaws for clamping small workpieces.
- Balance jaws with grippers for irregular and round workpieces.
- Grippers for different shape and type of workpiece.

**CONDIZIONI DI VENDITA**

I DISEGNI SONO RAPPRESENTAZIONI  
ESEMPLIFICATIVE DELLE GAMME DI PRODOTTI

LE DIMENSIONI E LE CARATTERISTICHE TECNICHE  
DEI PRODOTTI POSSONO VARIARE NEL TEMPO

EVENTUALI VARIAZIONI DI DIMENSIONI O CARATTERISTICHE  
TECNICHE VERRANNO COMUNICATE VIA NEWSLETTER

PER RICHIESTE SCRIVERE A [info@caporali.net](mailto:info@caporali.net)

**CONDITIONS OF SALE**

DRAWINGS ARE EXAMPLES OF RANGE OF PRODUCTS

SIZES AND TECHNICAL FEATURES OF PRODUCTS  
MAY VARY OVER TIME

ANY VARIATIONS IN SIZES AND TECHNICAL FEATURES  
WILL BE COMMUNICATED BY NEWSLETTER

FOR INQUIRIES WRITE TO [info@caporali.net](mailto:info@caporali.net)



**www.caporali.net**

Scoprite la nostra offerta scaricando il catalogo dalla sezione download del sito.



**store.caporali.net**

acquisti on-line  
disponibilità dei prodotti  
riepilogo degli ordini aperti  
documenti on-line



**info@caporali.net**

*Tel: +39 02 66 012 728*

*Fax: +39 02 66 013 052*

*GAETANO CAPORALI S.r.l.  
Via Privata Bizet 23/25  
20092 Cinisello Balsamo (MI)  
Italy*