



# DOUBLEREK SYSTEM

Reliable shouldering applications with superior accuracy



*New small size inserts added.*



**DOUBLEREK**

<b>P</b>	<b>M</b>	<b>K</b>	<b>N</b>	<b>S</b>	<b>H</b>
★	☆	★		☆	

- Shoulder milling
- KAPR = 90°
- Internal coolant
- Economical double-sided system
- Reliable and versatile system
- Stable and easy insert positioning

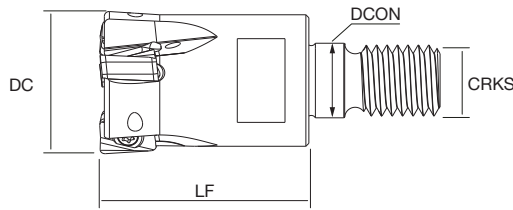

SCREW-IN

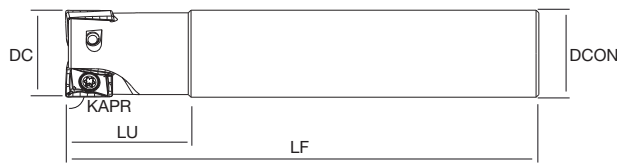

CYLINDRICAL

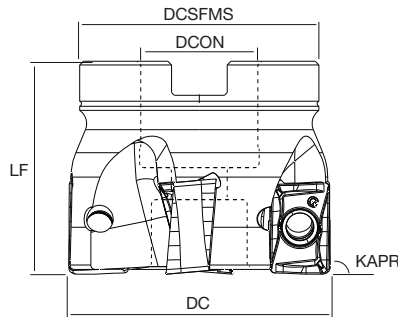

ARBOR



	Designation	Stock	DC	ZEFP	DCON	DCSFMS	LF	LU	CRKS	WT	MIID
SCREW-IN	NT-DRK10 D016-M08-Z02	●	16	2	8.5		25		M8	0.05	NT-DRK10
	NT-DRK10 D020-M10-Z03	●	20	3	10.5		30		M10	0.10	NT-DRK10
	NT-DRK10 D025-M12-Z03	●	25	3	12.5		35		M12	0.15	NT-DRK10
	NT-DRK10 D032-M16-Z04	●	32	4	16.0		43		M16	0.25	NT-DRK10
CYLINDRICAL	NT-DRK10 D016-S16-Z02	●	16	2	16		100	25		0.15	NT-DRK10
	NT-DRK10 D020-S20-Z03	●	20	3	20		110	30		0.25	NT-DRK10
	NT-DRK10 D025-S25-Z03	●	25	3	25		120	35		0.45	NT-DRK10
	NT-DRK10 D032-S32-Z04	●	32	4	32		130	45		0.75	NT-DRK10
	NT-DRK17 D032-S32-Z02	●	32	2	32		130	45		0.70	NT-DRK17
	NT-DRK17 D040-S32-Z03	●	40	3	32		150	40		1.90	NT-DRK17
ARBOR	NT-DRK10 D032-F16-Z04	●	32	4	16	30	40			0.15	NT-DRK10
	NT-DRK10 D040-F16-Z05	●	40	5	16	30	40			0.20	NT-DRK10
	NT-DRK10 D050-F22-Z05	●	50	5	22	40	40			0.35	NT-DRK10
	NT-DRK10 D050-F22-Z07	●	50	7	22	40	40			0.30	NT-DRK10
	NT-DRK10 D063-F22-Z06	●	63	6	22	55	40			0.65	NT-DRK10
	NT-DRK10 D063-F22-Z08	●	63	8	22	55	40			0.60	NT-DRK10
	NT-DRK10 D080-F27-Z07	●	80	7	27	60	50			1.30	NT-DRK10
	NT-DRK10 D080-F27-Z10	●	80	10	27	60	50			1.25	NT-DRK10
	NT-DRK17 D050-F22-Z04	●	50	4	22	45	40			0.30	NT-DRK17
	NT-DRK17 D063-F22-Z05	●	63	5	22	55	40			0.55	NT-DRK17
	NT-DRK17 D063-F22-Z06	●	63	6	22	55	40			0.55	NT-DRK17
	NT-DRK17 D080-F27-Z06	●	80	6	27	60	50			1.15	NT-DRK17
	NT-DRK17 D080-F27-Z07	●	80	7	27	60	50			1.10	NT-DRK17
	NT-DRK17 D100-F32-Z07	●	100	7	32	78	50			1.75	NT-DRK17
	NT-DRK17 D100-F32-Z09	●	100	9	32	78	50			1.75	NT-DRK17
	NT-DRK17 D125-F40-Z08	●	125	8	40	80	63			3.20	NT-DRK17
	NT-DRK17 D125-F40-Z10	●	125	10	40	80	63			3.15	NT-DRK17

[www.nikkotools.com](http://www.nikkotools.com)



Via Don F. Tosatto, 8  
30174 Mestre - Venezia  
+39 041.959179  
[info@nikkotools.com](mailto:info@nikkotools.com)



\$NKDEP22DRK